



EV3372-R-00A

8-Channel, Synchronous Boost WLED Driver with I²C Interface Evaluation Board

DESCRIPTION

The EV3372-R-00A is an evaluation board for the MP3372, a synchronous boost converter with eight current channels. The IC is designed to drive WLED arrays for LCD panels in tablets and notebook backlighting applications.

The MP3372 uses peak current mode and pulse-width modulation (PWM) control to regulate the boost converter. The MP3372 employs a standard I²C digital interface to set the operation mode, switching frequency, full-scale current for each channel, sync or non-sync mode, dimming mode and duty, and various protection thresholds.

The low-headroom voltage for LED regulation and small on resistance of the switching MOSFET provide the MP3372 with high efficiency. The synchronous rectifier saves PCB size and total BOM cost.

The MP3372 is available in a QFN-24 (4mmx4mm) package.

ELECTRICAL SPECIFICATIONS

Parameter	Symbol	Value	Units
Input voltage	V _{IN}	3 to 30	V
Output voltage	V _{LED}	<45	V
LEDs#		8 strings	
LED current/string	I _{LED}	50	mA

FEATURES

- 3V to 30V Input Voltage Range
- Maximum 2.5% Current Matching
- 350kHz/500kHz/650kHz/800kHz/950kHz/1.2MHz Selectable f_{sw}
- A1 Pins for Two I²C Addresses
- 0mA to 50mA Full-Scale LED Current, 8 Bits, 0.196mA/Step
- Selectable Sync or Non-Sync Mode
- Multi-Dimming Operation Mode Includes:
 - Analog Dimming via External PWM Input, 10-Bit Resolution
 - Analog Dimming via I²C, 10-Bit Resolution
 - PWM Dimming via External PWM Input, 14-Bit Resolution
 - PWM Dimming via I²C, 14-Bit Resolution
 - Mixed Dimming Mode via External PWM Input with 6.25%/12.5%/25%/50% Transfer Point, 14-Bit PWM Duty Resolution
 - Mixed Dimming Mode via I²C with 6.25%/12.5%/25%/50% Transfer Point, 14-Bit PWM Duty Resolution
- Phase Shift Function during PWM Dimming (Including PWM Dimming during Mixed Dimming)
- Linear Smooth Dimming with 2μs, 4μs, 8μs, 16μs, 32μs, 64μs, or 128μs Step-Slope Set
- Unused LED String Auto-Disable at Start-Up
- LED Short/Open Protection, OTP, OCP, Inductor or Diode Short Protection:
 - 2.5V, 5V, 7.5V, 10V LED Short Threshold
 - 24V, 31V, 37.5V, or 46V OVP Threshold
 - 1.8 or 2.5A Current Limit
- Cascade Function to Share Power Stage
- Available in a QFN-24 (4mmx4mm) Package

APPLICATIONS

- Tablets/Notebooks
- Automotive Displays

All MPS parts are lead-free, halogen free, and adhere to the RoHS directive. For MPS green status, please visit MPS website under Quality Assurance. "MPS", the MPS logo, and "Simple, Easy Solutions" are Registered Trademarks of Monolithic Power Systems, Inc. or its subsidiaries.

EV3372-R-00A EVALUATION BOARD



(LxW) 6.2cmx4.4cm

Board Number	MPS IC Number
EV3372-R-00A	MP3372GR

QUICK START GUIDE

1. Connect the terminals of the power supply (3V to 30V) to:
 - a) Positive (+): VIN_Boost
 - b) Negative (-): GND
2. Connect the terminals of the load panel (8 strings) to:
 - a) Positive (+): LED+ pin
 - b) Negative (-): LED1–8 pins

Connect unused strings (unused LEDx pin(s)) to GND using a 0Ω resistor.
3. Connect the EN pin to enable IC with a high-level signal (> 1.2V).
4. Connect SCL, SDA, and GND to their respective locations on the configurable kit (EVKT-USBI2C-02) with an I²C interface.
5. If working in external dimming mode, add a PWM input signal to the PWM terminal on the evaluation board. If working in internal dimming mode, the PWM pin can be left alone or pulled to GND.

POWER-ON SEQUENCE

1. VIN powers on.
2. EN powers on.
3. Set the registers using the GUI I²C interface (see Figure 1).
4. The PWM signal and LED string(s) should turn on.
5. Program the PWM duty cycle to dim the LED current.

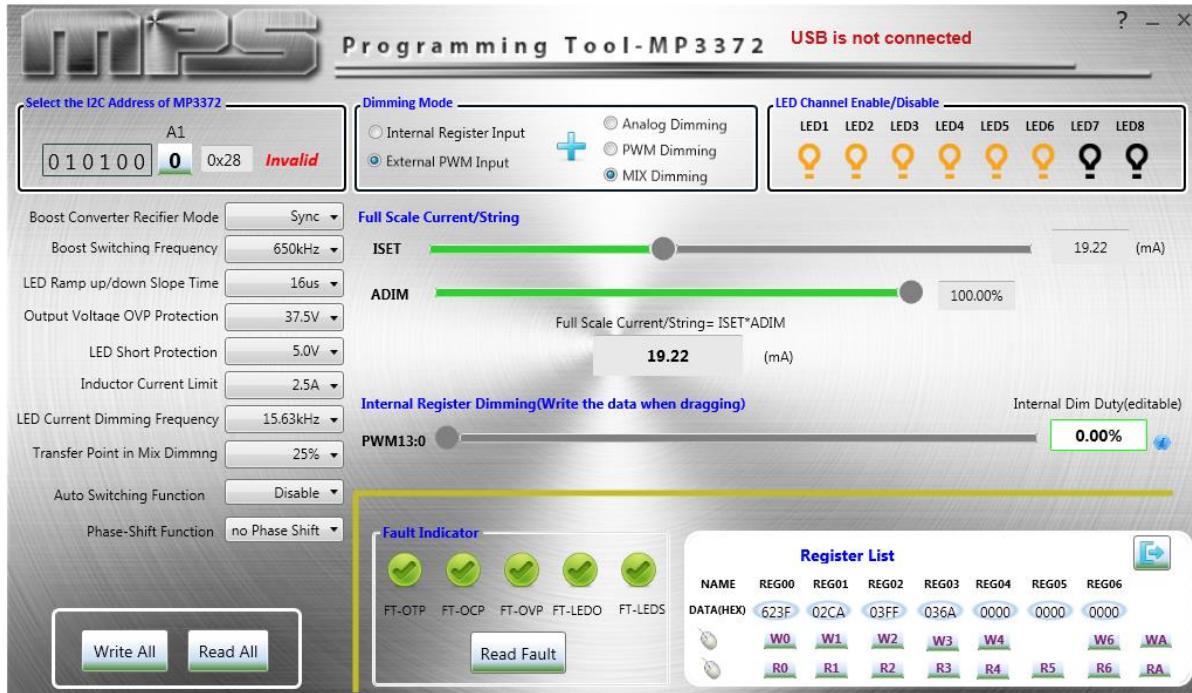
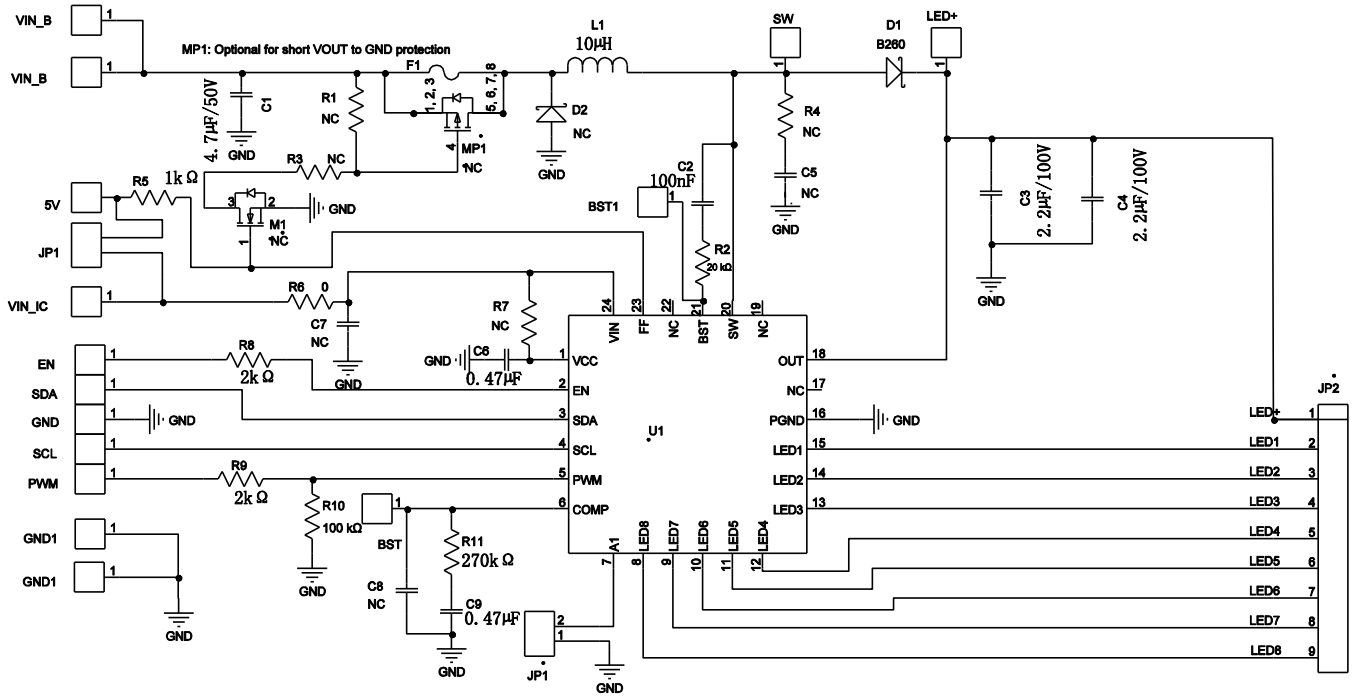

Figure 1: MP3372 GUI Interface

EVALUATION BOARD SCHEMATIC



EV3372-R-00A BILL OF MATERIALS

Qty	Ref	Value	Description	Package	Manufacturer	Manufacturer P/N
1	F1	0Ω	Fuse or resistor	1206	muRata	RC1206JR-070RL
1	MP1	NC	PMOS	SO-8		
1	C1	4.7μF	Ceramic capacitor, 50V, X7R	1210	muRata	GRM32ER71H475KA88L
1	C2	100nF	Ceramic capacitor, 16V, X7R	0603	muRata	GRM188R71C104KA01D
2	C3, C4	2.2μF	Ceramic capacitor, 100V, X7R	1210	muRata	GRM32ER72A225KA35L
2	C6,C9	470nF	Ceramic capacitor, 16V, X7R	0603	muRata	GRM188R71C474KA88D
3	C5, C7, C8	NC	Ceramic capacitor	0603		
1	D1	NC	B190	SMA		
1	D2	NC		SMA		
1	L1	10μH	Inductor, 36mΩ, 3.2A	SMD	KENJET	KJH8D43-100N
1	R2	20Ω	Resistor, 20Ω, 1%	0603	Yageo	RC0603FR-0720RL
1	R5	1kΩ	Resistor, 1kΩ, 1%	0603	Yageo	RC0603FR-071KL
1	R6	0Ω	Resistor, 0Ω, 1%	0603	Yageo	RC0603FR-070RL
2	R8, R9	2kΩ	Resistor, 2kΩ, 1%	0603	Yageo	RC0603FR-072KL
1	R10	100kΩ	Resistor, 100kΩ, 1%	0603	Yageo	RC0603FR-07100RL
1	R11	270Ω	Resistor, 270Ω, 1%	0603	Yageo	RC0603FR-07270RL
5	R1, R3, R4, R7, R12	NC	Resistor	0603		
1	U1	MP3372	LED driver with I ² C interface	QFN-24 (4mmx4mm)	MPS	MP3372GR