

# EVB-USB7252

## Table of Contents

Sheet	Description
1	Table of Contents, Block Diagram
2	USB7252
3	USB Type-uB Upstream, SPI, I2S
4	USB (Type-C) Downstream Ports 1-2
5	USB (Type-A) Downstream Ports 3-4
6	Voltage Regulators

## Revision History

Revision	Date	Revision Summary	Author
1.1	2/14/2019	Released to DevTools	Mick Davis

## Notes

1	All resistors are 1% unless specified otherwise
2	Shunt jumper default selections are marked with an asterisk [*].

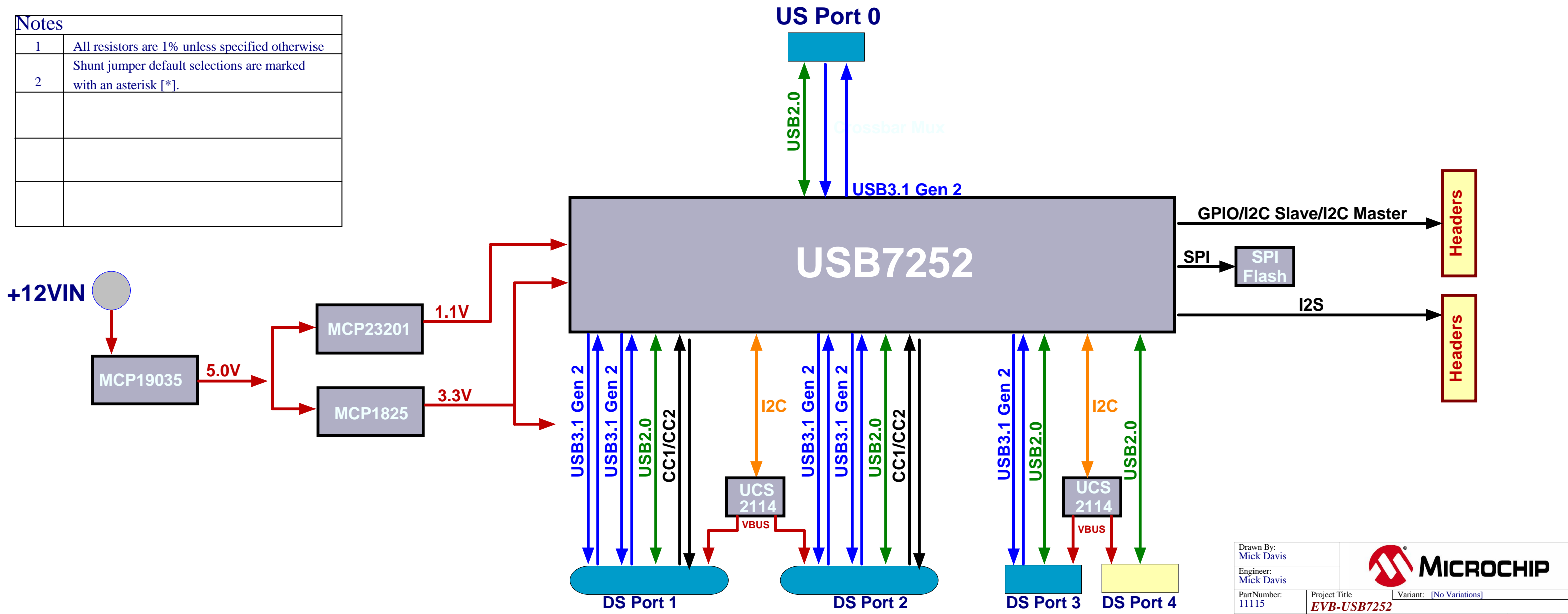

Drawn By: Mick Davis		
Engineer: Mick Davis		
PartNumber: 11115	Project Title <b>EVB-USB7252</b>	Variant: [No Variations]
Sheet Title Table of Contents and Block Diagram		
Size Tabloid	Sch #:03-11115 Revision: 1.1	Date: 3/2/2020 10:18:27 AM Sheet 1 of 6
File: 11115-1-TOC.SchDoc		 Altium.com

# USB7252

\*Note: The polarity of USB Super Speed differential pairs may be swapped to facilitate simplified PCB layout. All USB3 PHYs have built in auto-polarity detection and correction. This does not apply to USB2 signals.

## Default PF Functions

USB7252		USB7252	
PF2	DP1_VCONN1	PF17	PRT_CTL1
PF3	DP1_VCONN2	PF18	ALERT0
PF4	DP2_DISCHARGE	PF19	I2S_SDO
PF5	DP1_DISCHARGE	PF20	SPI_CE_N
PF6	See Datasheet	PF21	SPI_CLK
PF7	MIC_DET	PF22	SPI_D0
PF8	See Datasheet	PF23	SPI_D1
PF9	See Datasheet	PF24	SPI_D2
PF10	DP2_VCONN1	PF25	SPI_D3
PF11	DP2_VCONN2	PF26	I2S_SCLK
PF12	See Datasheet	PF27	I2S_MCLK
PF13	PRT_CTL3	PF28	I2S_LCLK
PF14	I2S_SDI	PF29	See Datasheet
PF15	PRT_CTL2	PF30	MSTR_I2C_CLK
PF16	PRT_CTL4	PF31	MSTR_I2C_DATA

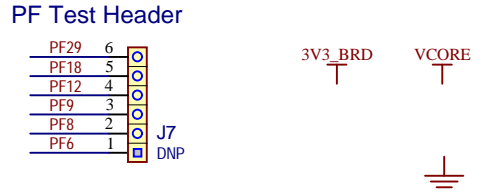
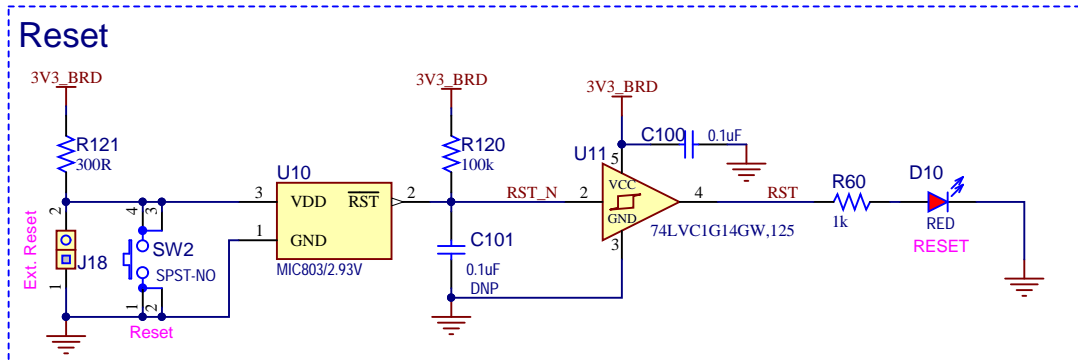
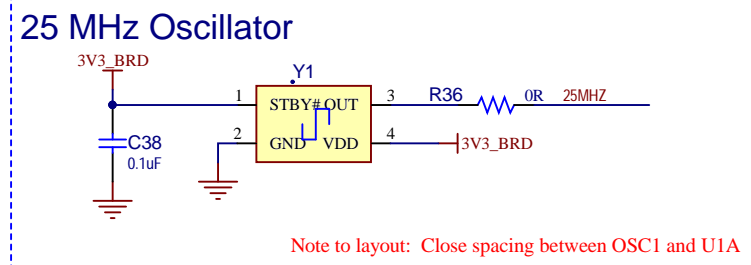
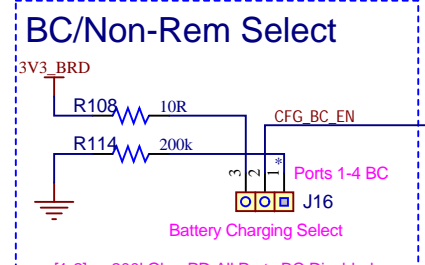
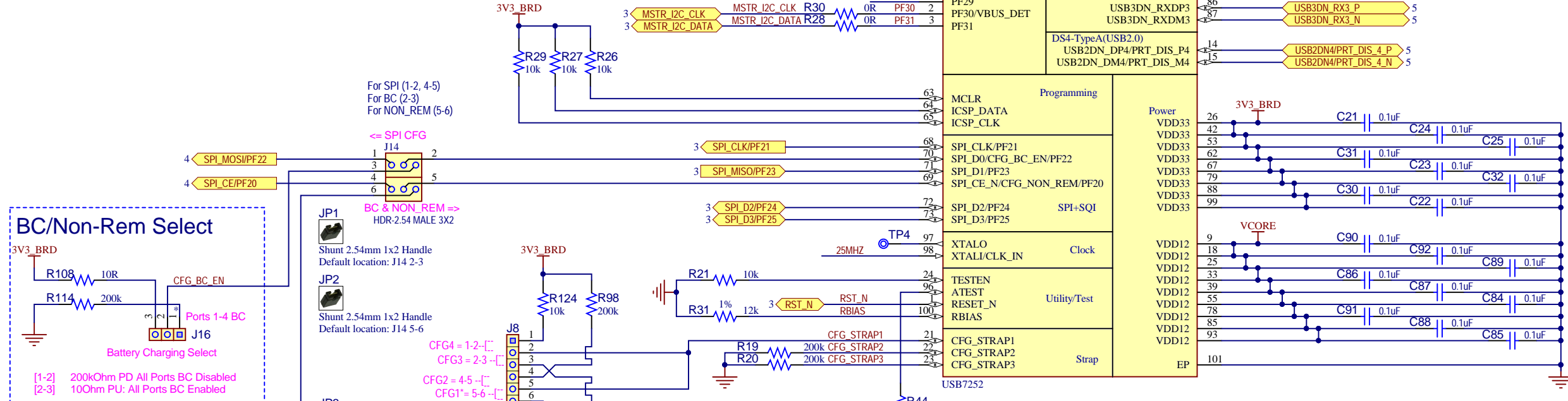
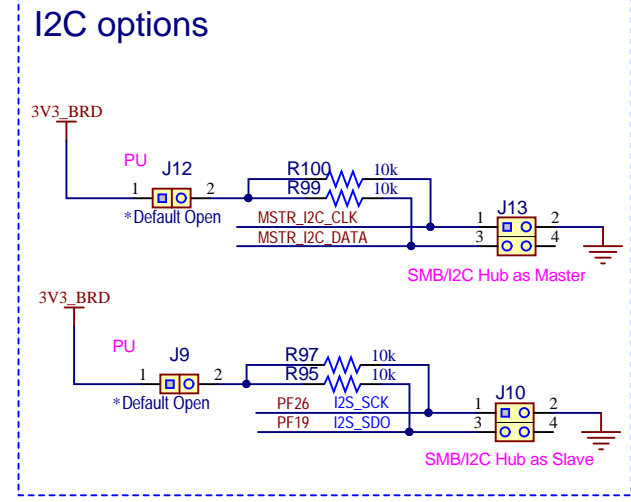
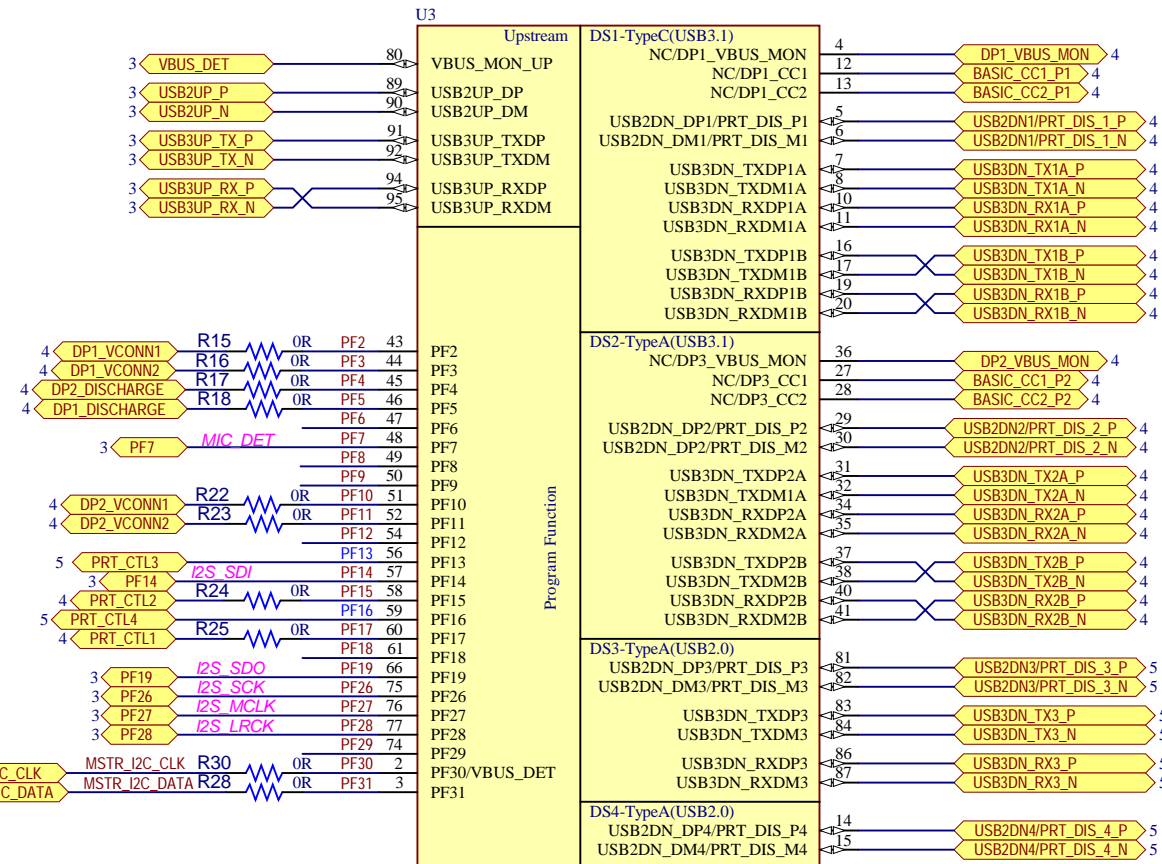

Drawn By: Mick Davis  
 Engineer: Mick Davis  
 PartNumber: 11115  
 Project Title: EVB-USB7252  
 Variant: [No Variations]  
 Sheet Title: USB7252  
 Size: Tabloid  
 Sch #: 03-11115  
 Date: 3/2/2020 10:18:28 AM  
 Revision: 1.1  
 Sheet: 2 of 6  
 File: 11115-2-USB7252.SchDoc

Note to layout: Close spacing between OSC1 and U1A

# USB-B Upstream, SPI, LED, GP Indicators

## USB-B Upstream Port 0

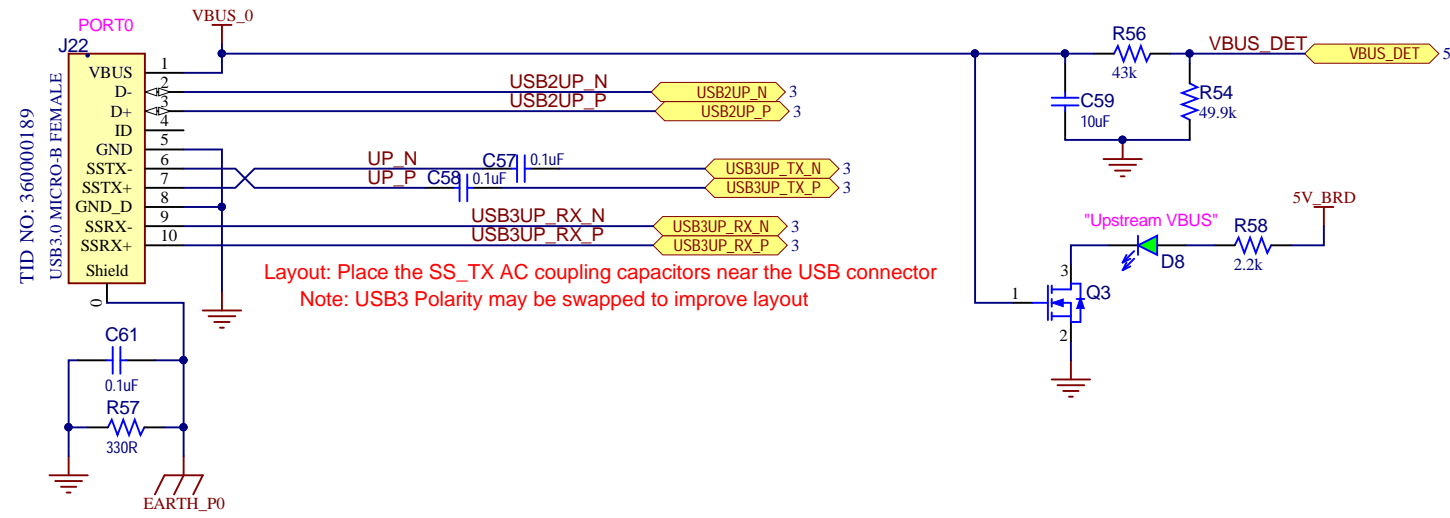

## SPI Flash

Layout: Arrange all signals in this block with minimal stubs

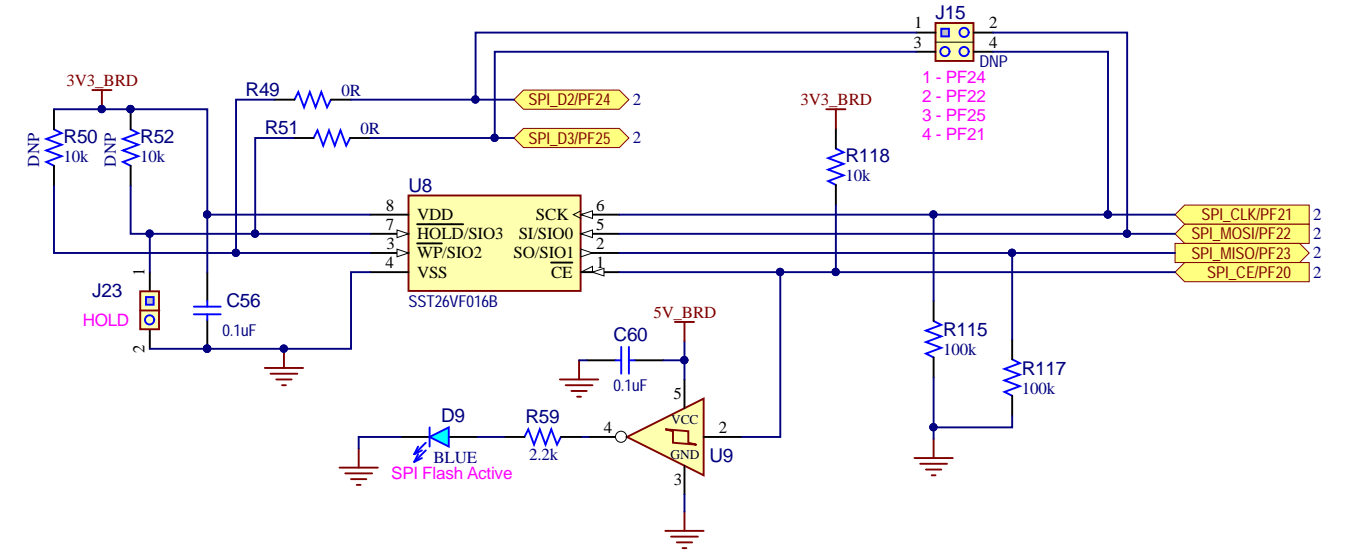

## I2S Module

NOTE: I2S Interface is only available under USB7252 - Config 2

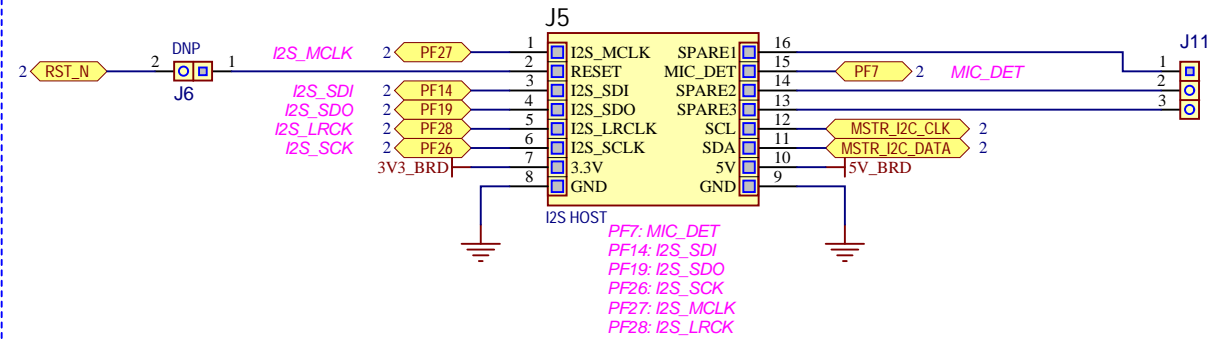

3V3\_BRD 5V\_BRD VBUS\_0

EARTH\_PO

Drawn By: Mick Davis		
Engineer: Mick Davis		
PartNumber: 11115	Project Title <b>EVB-USB7252</b>	Variant: [No Variations]
Sheet Title <b>USB-B Upstream Port 0, SPI Flash, I2S Module</b>		
Size Tabloid	Sch #:03-11115 Revision: 1.1	Date: 3/2/2020 10:18:28 AM Sheet 3 of 6
File: 11115-3-USB-B-Upstream.SchDoc		Designed with 

# USB3.2 (Type-C) Downstream Ports 1 and 2

## USB-C Downstream Port 1

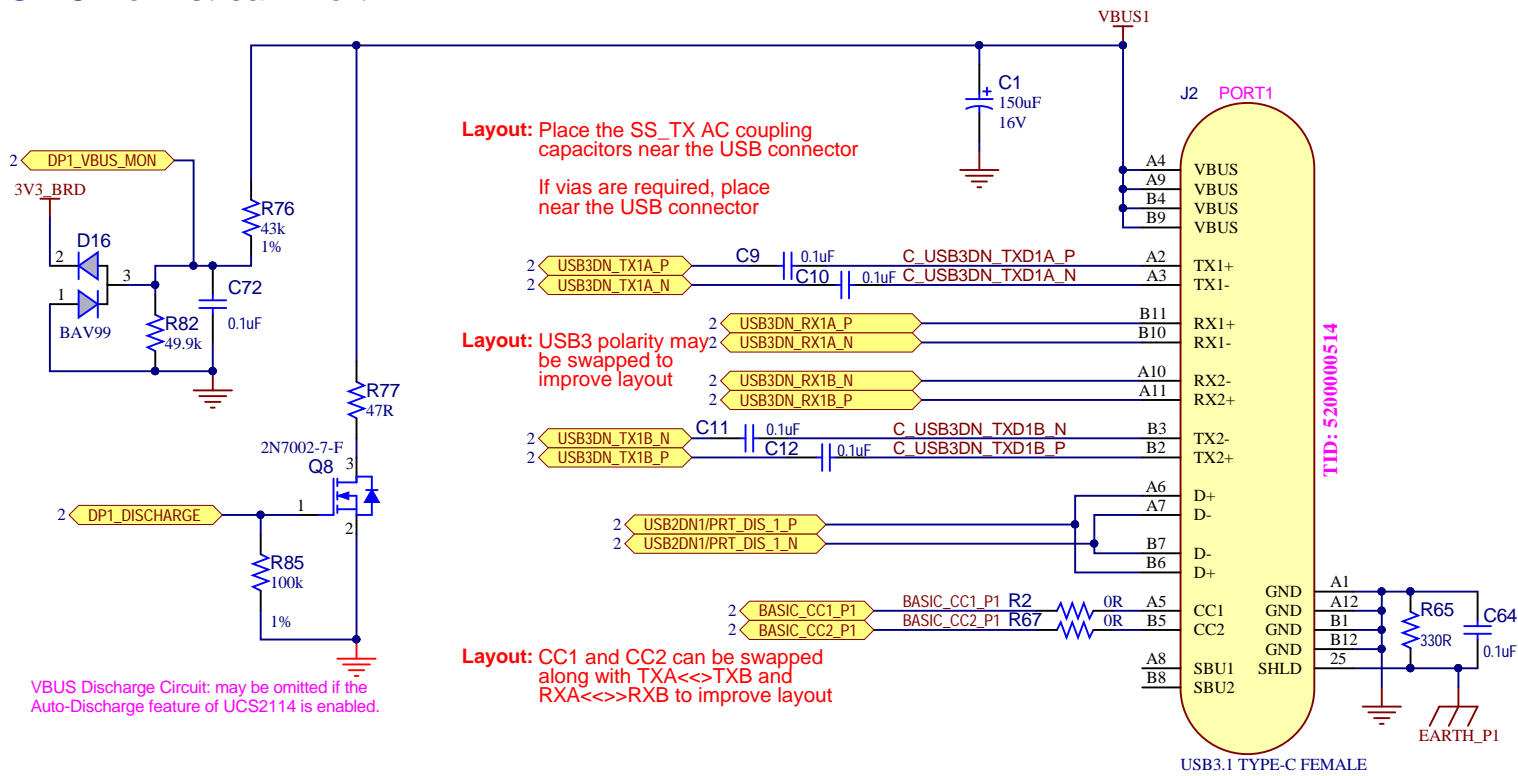

## UCS2114 Power Switch For Port1 and Port2

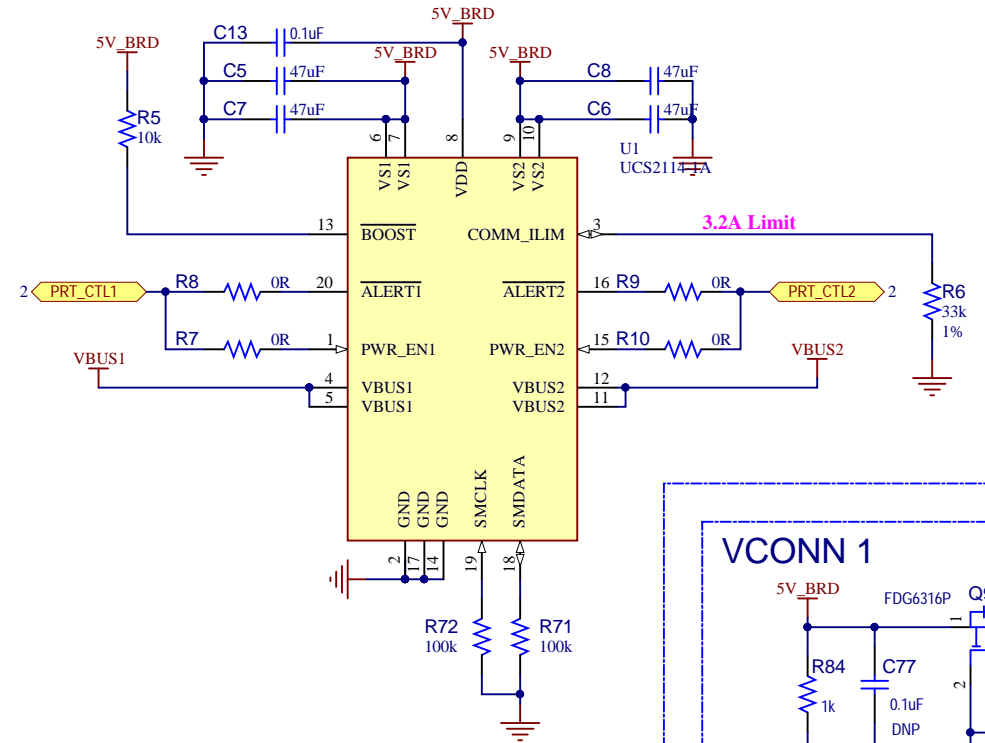

## VCONN 1

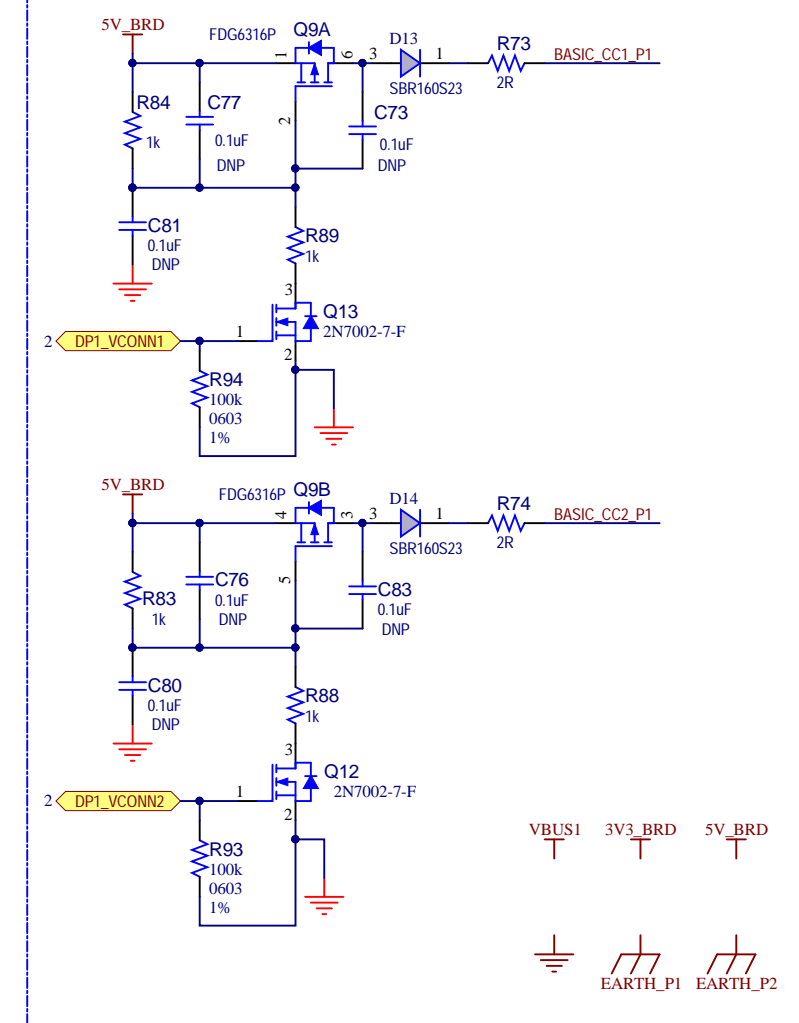

## USB-C Downstream Port 2

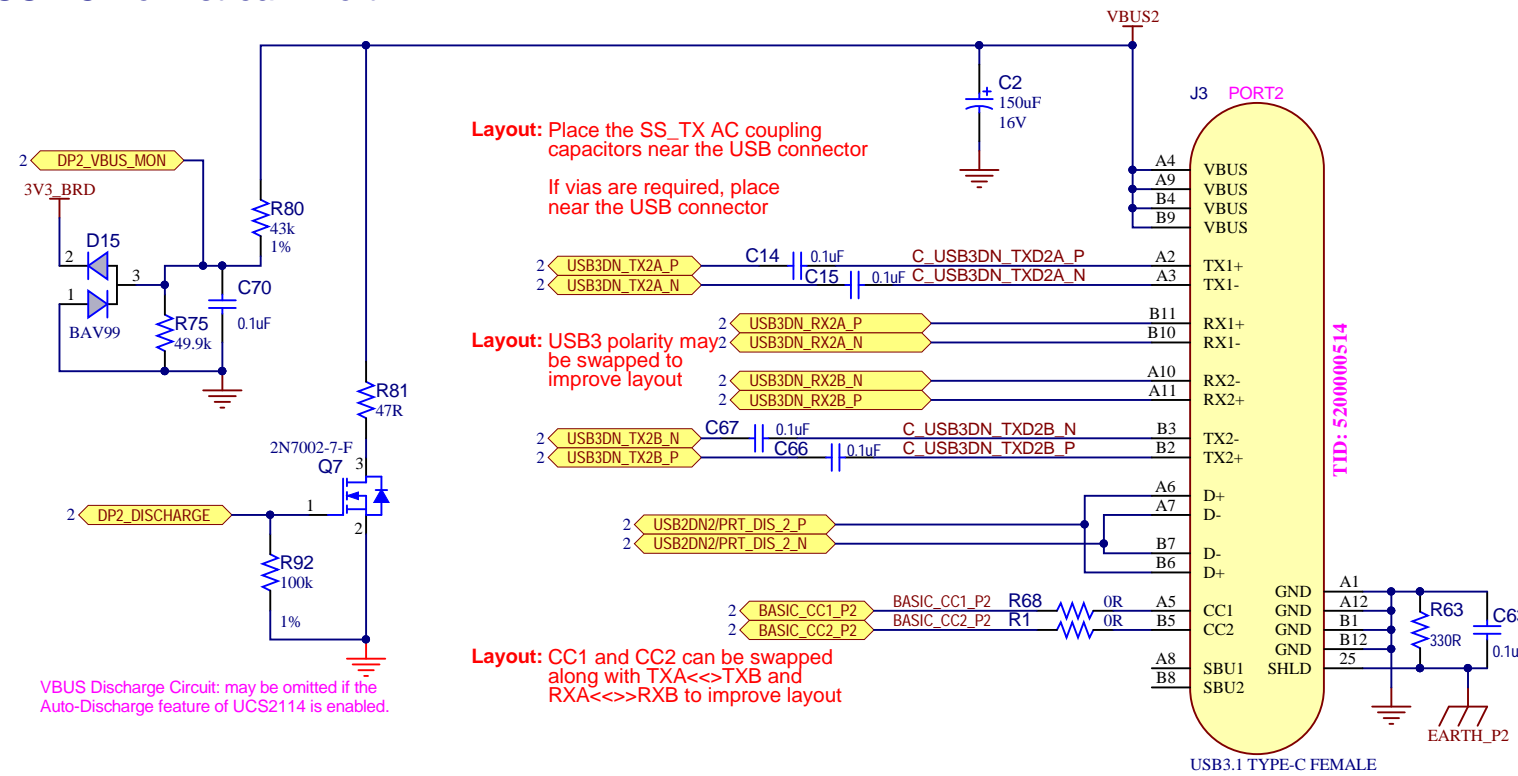

## VCONN 2

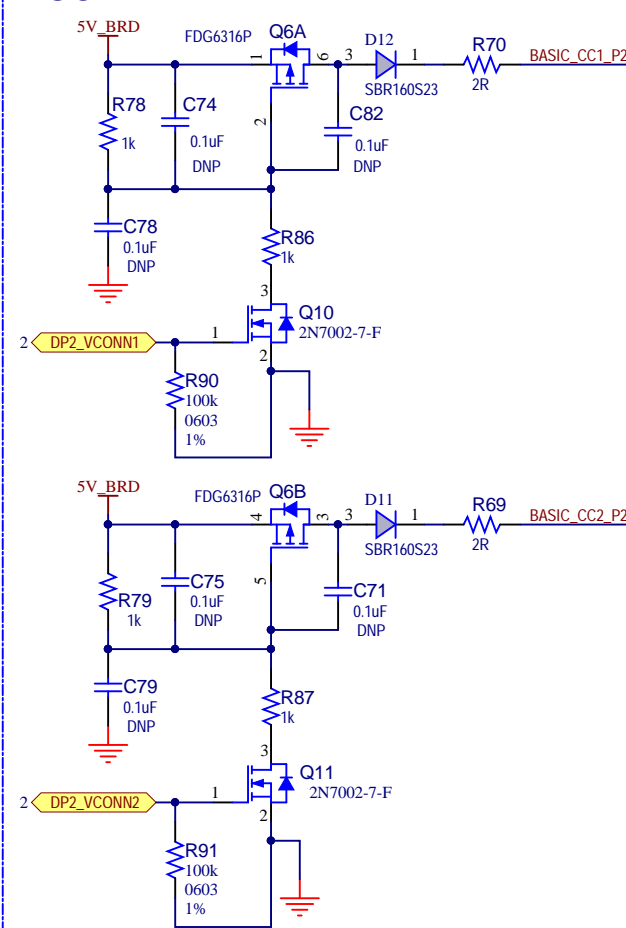

Drawn By: Mick Davis			
Engineer: Mick Davis			
PartNumber: 11115	Project Title: EVB-USB7252	Variant: [No Variations]	
Sheet Title: USB3.2 (Type-C) Downstream Ports 1 and 2			
Size: Tabloid	Sch #:03-11115	Date: 3/2/2020 10:18:29 AM	Designed with Altium
Revision: 1.1	Sheet 4 of 6		Altium.com
File: 11115-4-USB-C Downstream 1-2.SchDoc			

# USB (Type-A) Downstream Ports 3-4

UCS2114 Power Switch For Port3 and Port4

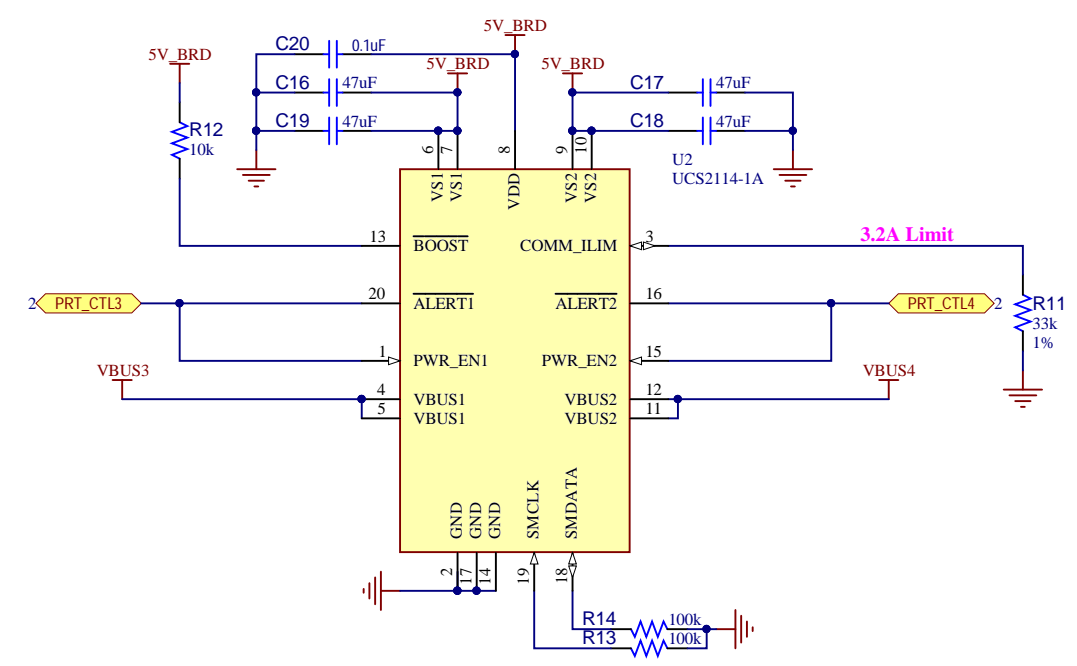

USB3.1(Type-A) Downstream Port 3

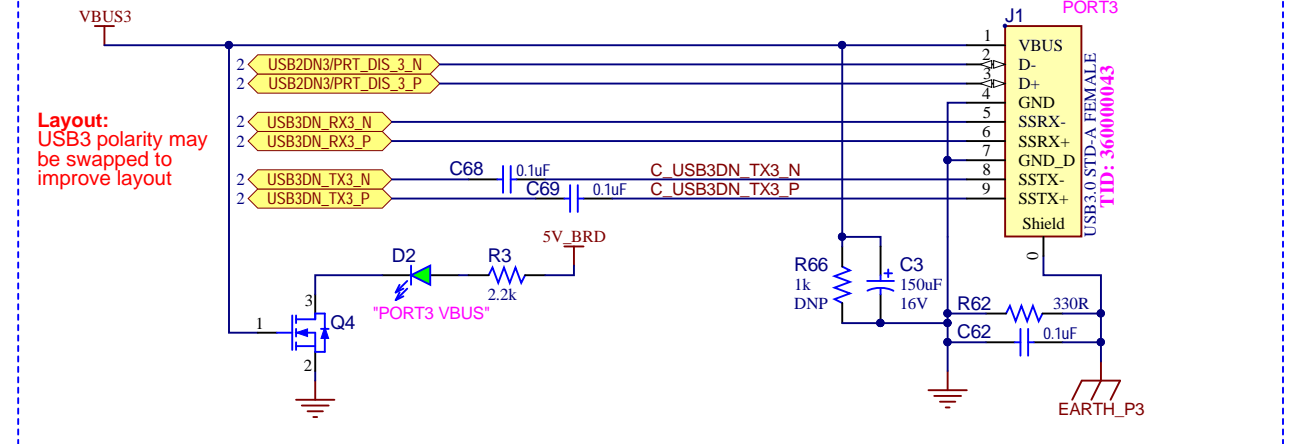

USB-A Downstream Port 4

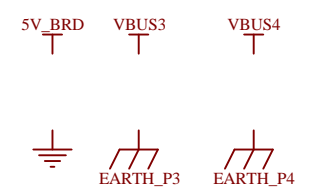
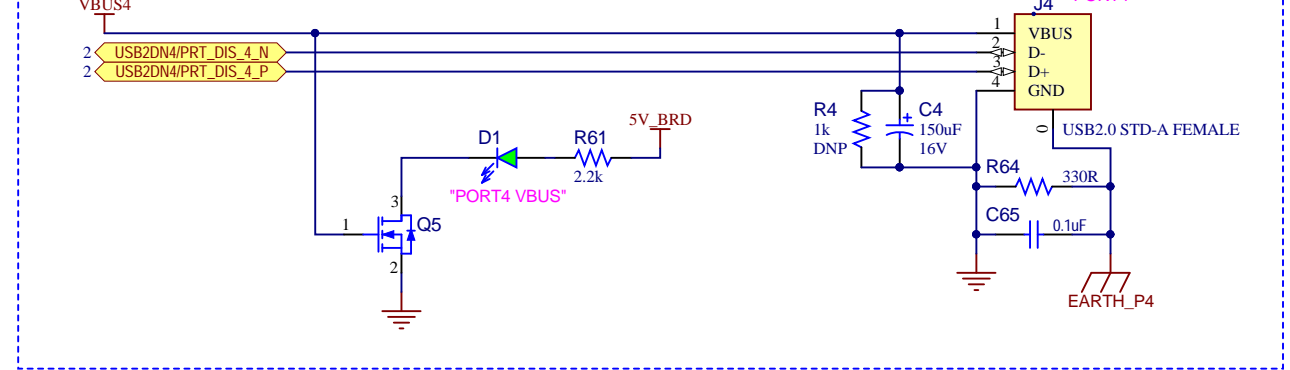

Drawn By: Mick Davis		
Engineer: Mick Davis		
PartNumber: 11115	Project Title <b>EVB-USB7252</b>	Variant: [No Variations]
Sheet Title <b>USB (Type-A) Downstream Ports 3-4</b>		
Size Tabloid	Sch #:03-11115 Revision: 1.1	Date: 3/2/2020 10:18:29 AM Sheet 5 of 6
File: 11115-5-USB-A Downstream 3-4.SchDoc		Designed with  Altium.com