



The Future of Analog IC Technology®

EV4816A-G-00A

180V, 16-Channel Analog Switch Evaluation Board

DESCRIPTION

The EV4816A-G-00A is an evaluation board for the MP4816A, a high voltage 16-channel analog switch. The MP4816A is designed for medical ultrasound application. It can also be used for non-destructive test (NDT) as the application is very similar to medical ultrasound.

The high voltage analog switches are used to multiplex the transmitter and receiver circuitries to different piezoelectric transducer (PZT) elements. The MP4816A has a resistor to ground on the output pins, SWout. This is to help ensure there is no significant DC voltage built up across the PZT element. The switches can be turned on/off via a serial 16-bit shift register. The serial control interface will help minimize the number of I/O connection.

FEATURES

- 16 Channels
- No High Voltage Bias Required
- Up to ±90V Analog Signal
- 12.5Ω Typical Switch Resistance
- ±2.0A Typical Switch Peak Current
- 80MHz Clock Frequency at VLL=5.0V
- 40MHz Clock Frequency at VLL=3.3V
- Integrated Bleed Resistors – MP4816A

APPLICATIONS

- Medical Ultrasound
- Industrial NDT

All MPS parts are lead-free, halogen free, and adhere to the RoHS directive. For MPS green status, please visit MPS website under Quality Assurance.

"MPS" and "The Future of Analog IC Technology" are Registered Trademarks of Monolithic Power Systems, Inc.

EV4816A-G-00A EVALUATION BOARD

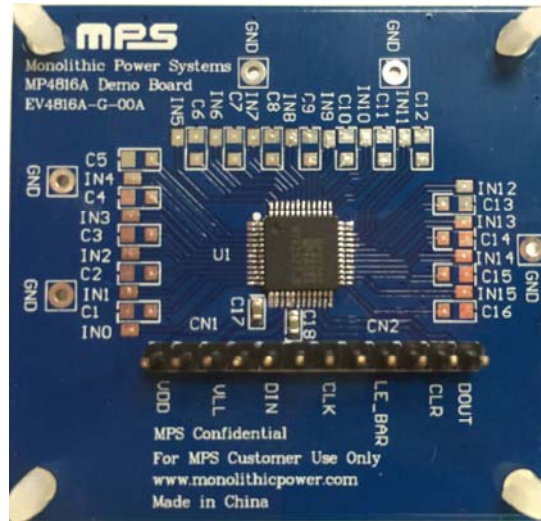

(L x W x H) 2.0" x 1.9" x 0.0625"
(5.08cm x 4.83cm x 0.016cm)

Board Number	MPS IC Number
EV4816A-G-00A	MP4816AGFP

EVALUATION BOARD SCHEMATIC

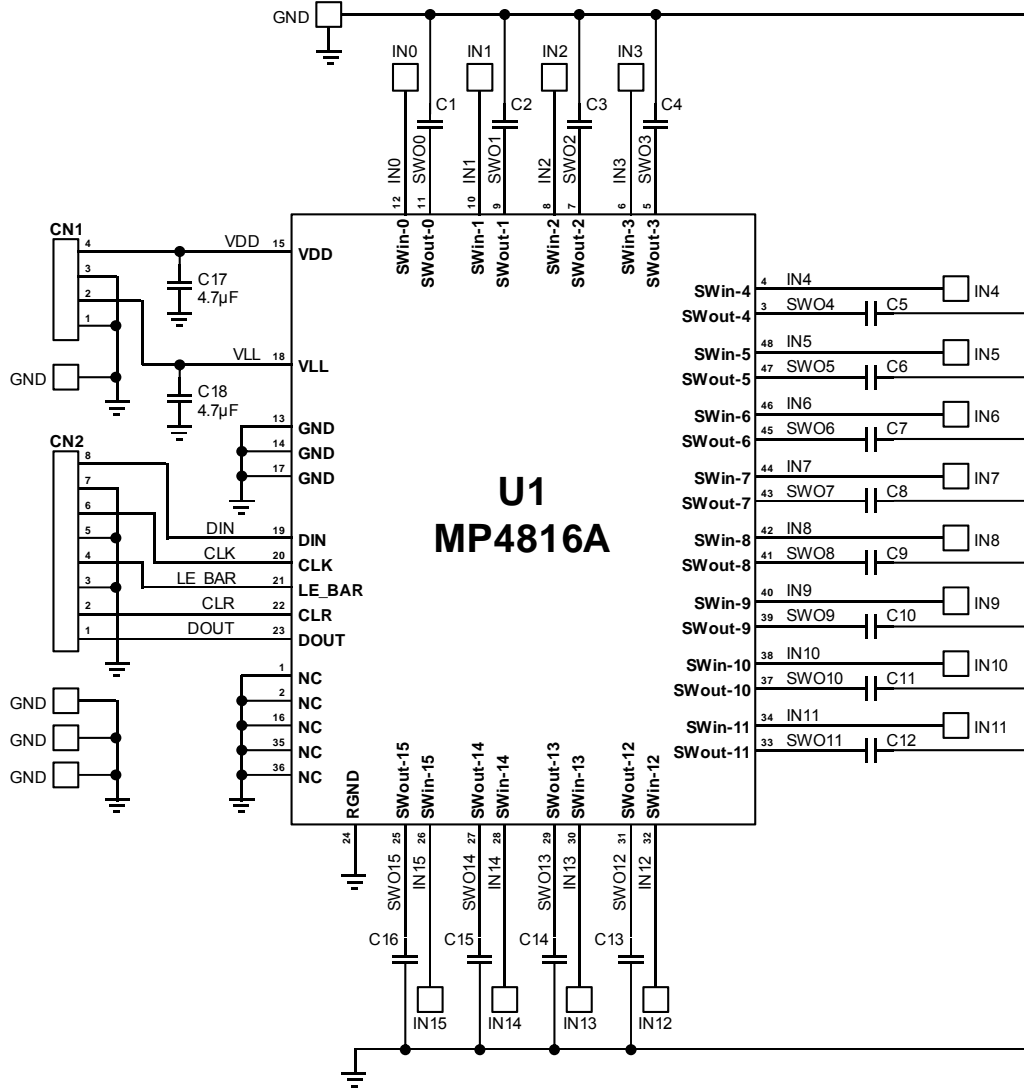

EV4816A-G-00A BILL OF MATERIALS

Qty	Ref	Value	Description	Package	Manufacturer	Part Number
2	C17, C18	4.7µF	Ceramic, 16V, X7R	0603	muRata	GRM188R61C475KAAJD
16	C1-C16	NS		0805		
1	U1		180V, 16-ch analog switch	TQFP-48	MPS	MP4816A
1	CN1	4pin	4 pin header, 0.100" pitch		Molex	
1	CN2	8pin	8 pin header, 0.100" pitch		Molex	

PRINTED CIRCUIT BOARD LAYOUT

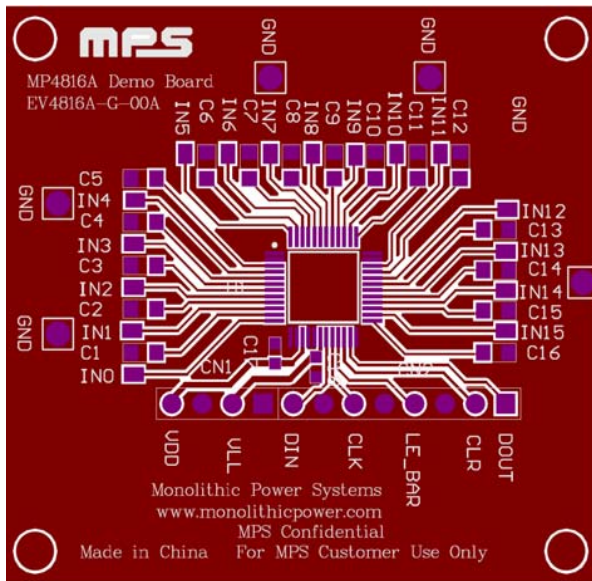

Figure 1—Top Layer

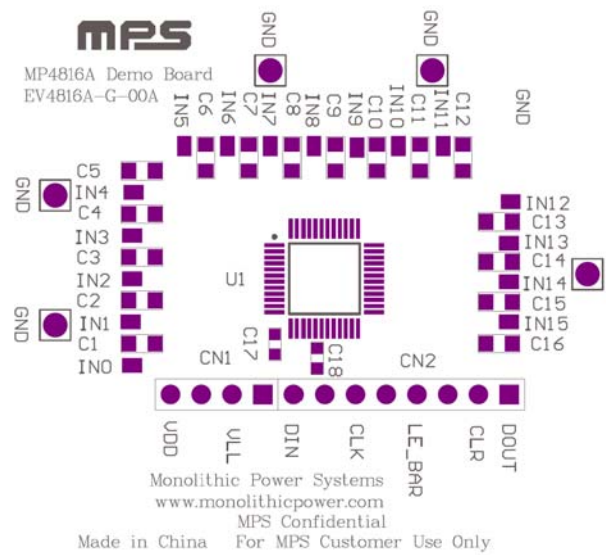

Figure 2—Top Silk Layer

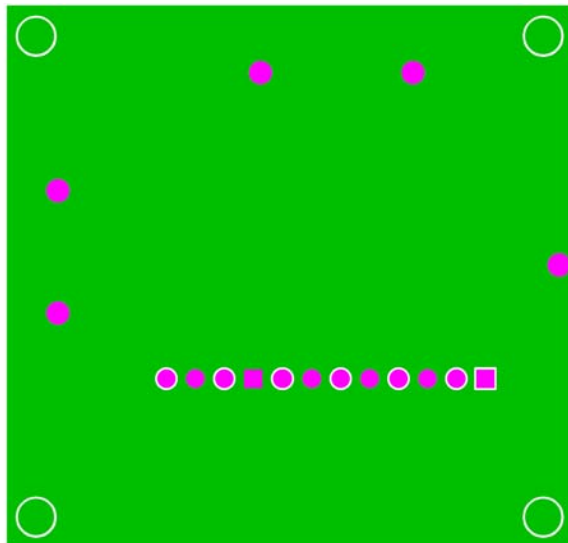

Figure 3—Bottom Layer

FUNCTIONAL BLOCK DIAGRAM

