



EV5611-QT-00A

2.9V to 5.2V Input, Triple-Output, AMOLED Display Power Supply

DESCRIPTION

The MP5611 is a triple-output converter with a 2.9V to 5.2V input voltage (V_{IN}) range designed for small-size AMOLED (active matrix organic light-emitting diode) display power supplies.

The MP5611 integrates a boost converter for ELVDD, an inverting buck-boost (IBB) converter for ELVSS, and another boost converter for AVDD. The one wire digital control pin (CTRL) can program the ELVSS, ELVDD, and AVDD voltages following digital protocol.

The MP5611 supports an independent start-up sequence for AVDD and ELVDD via separate enable pins (EN_AVDD and CTRL). It also integrates an optional fast discharge function after the IC has been disabled.

The device features rich protections, including V_{IN} under-voltage lockout (UVLO), cycle-by-cycle current limit protection, thermal shutdown protection, short output protection, and over-current protection (OCP) for AVDD and ELVDD.

The fully integrated synchronous rectification solution with low on resistance improves total system efficiency, minimizes external components, and reduces PCB layout size.

The MP5611 is available in a TQFN-16 (3mmx3mm) package.

ELECTRICAL SPECIFICATIONS

Parameter	Symbol	Value	Units
Input voltage	V_{IN}	2.9 to 5.2	V
Output voltage	AVDD	5.8	V
	ELVDD	4.6	V
	ELVSS	-4	V
Output current	I_{AVDD}	≤ 100	mA
	I_{ELVDD}	≤ 500	mA
	I_{ELVSS}	≤ 500	mA

FEATURES

- 2.9V to 5.2V Input Voltage (V_{IN}) Range
- Triple Output AVDD, ELVDD, ELVSS
- High Accuracy for Output Voltage (V_{OUT})
- Good Line and Load Regulation
- Configurable $V_{ELVDD} = 4.6V$ to 5.2V, Default 4.6V
- Configurable $V_{ELVSS} = -1.4V$ to -6.4V, Default -4V
- 500mA Output Current (I_{OUT}) for ELVDD and ELVSS
- Configurable $V_{AVDD} = 5V$ to 7.7V, Default 5.8V
- 100mA I_{OUT} for AVDD
- Separate Enable Pins for AVDD and ELVDD
- Soft Start (SS)
- Active Fast Discharge Function
- Cycle-by-Cycle Current Limit Protection
- AVDD Output Over-Current Protection (OCP) 90mA to 270mA
- ELVDD Output OCP 80mA to 650mA
- Output Short-to-GND Protection
- Over-Temperature Protection (OTP)
- Available in a TQFN-16 (3mmx3mm) Package

APPLICATIONS

- AMOLED Smartphones
- AMOLED Displays

All MPS parts are lead-free, halogen-free, and adhere to the RoHS directive. For MPS green status, please visit the MPS website under Quality Assurance. "MPS", the MPS logo, and "Simple, Easy Solutions" are trademarks of Monolithic Power Systems, Inc. or its subsidiaries.

EV5611-QT-00A EVALUATION BOARD

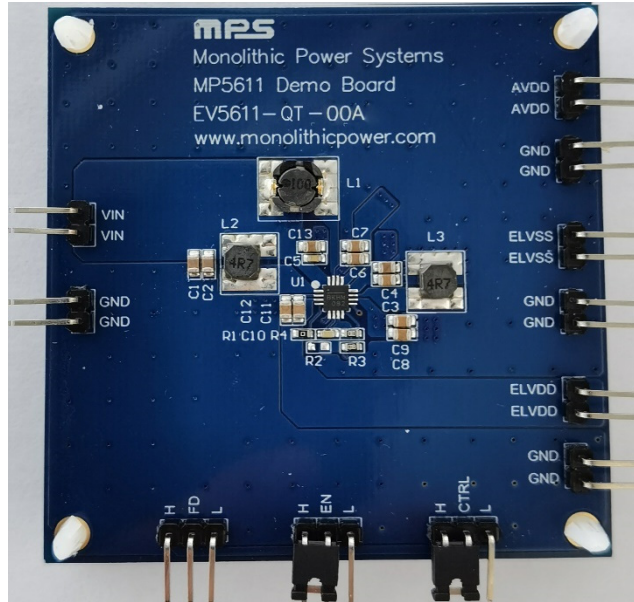

LxW (6.5cmx6.5cm)

Board Number	MPS IC Number
EV5611-QT-00A	MP5611GQT

QUICK START GUIDE

1. Connect the power supply (2.9V to 5.2V) terminals to:
 - a. Positive (+): VIN
 - b. Negative (-): GND
2. Connect the load terminals to:
 - a. AVDD (+): GND (-)
 - b. ELVDD (+): ELVSS (-)
3. Connect the EN pin to the H or L pin to enable or disable the AVDD output, respectively.
4. Connect the CTRL pin to H or L pin to enable or disable the ELVDD and ELVSS outputs, respectively.
5. Connect the FD pin to H or L pin to enable or disable the fast discharge function, respectively.
6. To program the output voltages (V_{OUT}) and over-current protection (OCP) thresholds, use the one wire function to apply a certain number of pulses to: ⁽¹⁾
 - a. Positive (+): CTRL
 - b. Negative (-): GND

Note:

- 1) Refer to the MP5611 datasheet for the number of required pulses.

EVALUATION BOARD SCHEMATIC

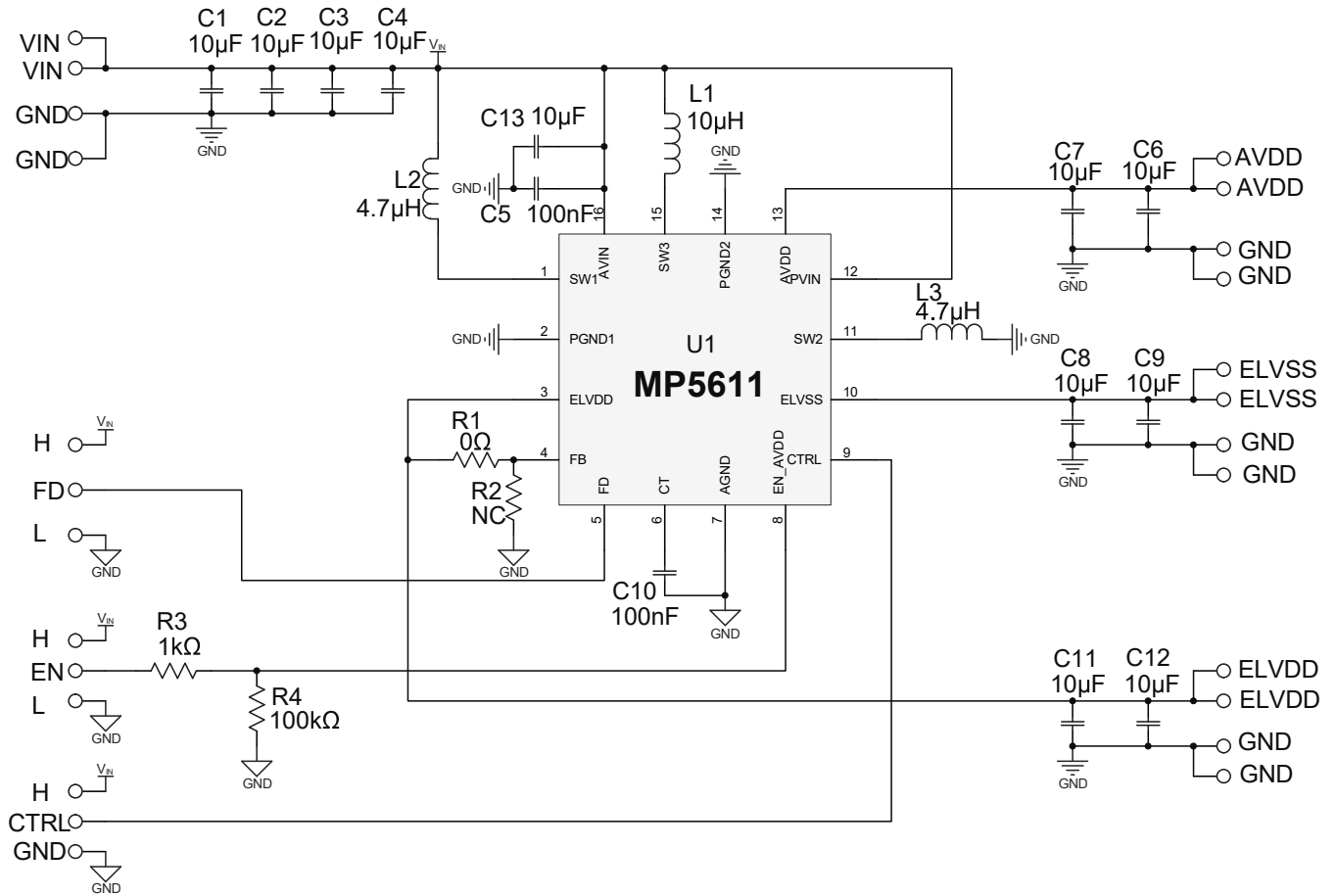

Figure 1: Evaluation Board Schematic

EV5611-QT-00A BILL OF MATERIALS

Qty	Ref	Value	Description	Package	Manufacturer	Manufacturer PN
11	C1, C2, C3, C4, C6, C7, C8, C9, C11, C12, C13	10 μ F	Ceramic capacitor, 10V, X7R	0805	Murata	GRM21BR71A106K E51L
2	C5, C10	100nF	Ceramic capacitor, 25V, X7R	0603	Murata	GCJ188R71E104KA 12D
1	L1	10 μ H	Inductor, 59m Ω , I _{SAT} = 1.14A	SMD	Toko	D63LCB-#A921CY-100M=P3
1	R1	0 Ω	Film resistor, 1%	0603	Yageo	RC0603FR-070RL
1	R3	1k Ω	Film resistor, 1%	0603	Yageo	RC0603FR-071KL
1	R4	100k Ω	Film resistor, 1%	0603	Yageo	RC0603FR-07100KL
1	R2	NC				
2	L2, L3	4.7 μ H	Inductor, 63m Ω , I _{SAT} = 2.6A	SMD	MPS	MPL-SE4030-4R7
1	U1	MP5611	Triple-output AMOLED display power supply	TQFN-16 (3mmx3mm)	MPS	MP5611GQT

PCB LAYOUT

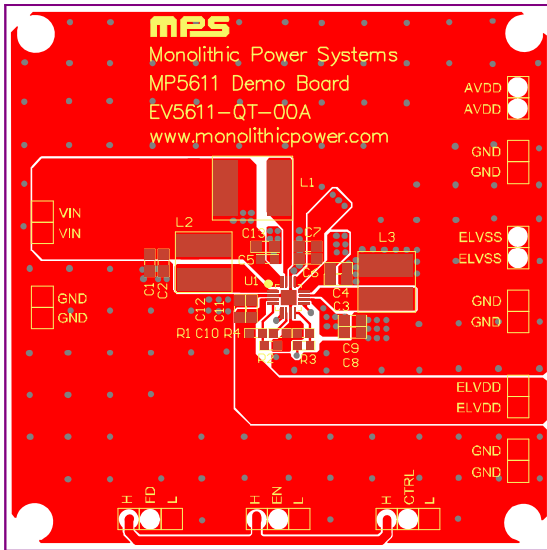

Figure 2: Top Layer

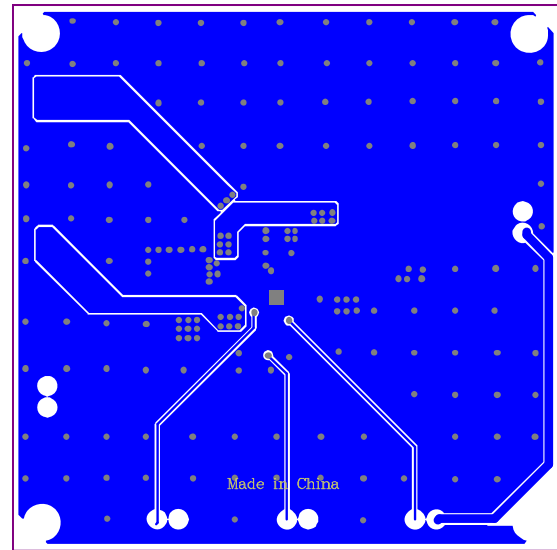

Figure 3: Bottom Layer