



# EV6504-V-00A

## 32V, 2A, Bipolar Stepper Motor Driver Evaluation Board

### DESCRIPTION

The EV6504-V-00A is an evaluation board for the MP6504GV, a stepper motor driver with a built-in microstepping translator.

The EV6504-V-00A operates from an 8V to 24V supply voltage range, and can deliver motor currents up to 2A. It can drive a bipolar stepper motor in full step, half-step, quarter-step, and eighth-step modes by setting MS2 and MS1. The input control signals and reference voltage for the MP6504GV are applied through the connector, or generated on the board.

### FEATURES

- Wide 8V to 32V Input Voltage Range
- Up to 2A Programmable Output Current
- Supports Full-, Half-, Quarter-, and Eighth-Step Modes
- Adjustable Mixed Decay Ratio or Automatic Decay
- OCP, OVP, and OTP
- Fault Indication Output

### APPLICATIONS

- Printers
- General Bipolar Stepper Drivers

### ELECTRICAL SPECIFICATIONS

Parameter	Symbol	Value	Units
Input voltage	$V_{IN}$	8 to 32	V
External VREF voltage	$V_{EXT\_REF}$	0 to 1	V
VCC voltage	$V_{CC}$	3.3 or 5	V
Decay mode	Automatic decay		

All MPS parts are lead-free, halogen-free, and adhere to the RoHS directive. For MPS green status, please visit the MPS website under Quality Assurance. "MPS", the MPS logo, and "Simple, Easy Solutions" are trademarks of Monolithic Power Systems, Inc. or its subsidiaries.

## EV6504-V-00A EVALUATION BOARD



(LxW) 6.35cmx6.35cm

Board Number	MPS IC Number
EV6504-V-00A	MP6504GV

## QUICK START GUIDE

1. Attach the input voltage ( $8V \leq V_{IN} \leq 32V$ ) to the VIN connector, and the input ground to the GND connector.
2. Switch SW2 and SW3 to position 3 (top side). This enables the external reference voltage input from the EXT\_REF connector, as well as the step signal input from the EXT\_STEP connector.
3. Attach the reference voltage ( $0V \leq V_{EXT\_REF} \leq 1V$ ) to the EXT\_REF connector to set the output current.
4. Attach the step signal to the EXT\_STEP connector.
5. Set the input control and logic signal through the CN1 connector via the external MCU, or through SW1 via manual action. Manual action requires an external 3.3V or 5V VCC voltage as a pull-up power supply.

### EVALUATION BOARD SCHEMATIC

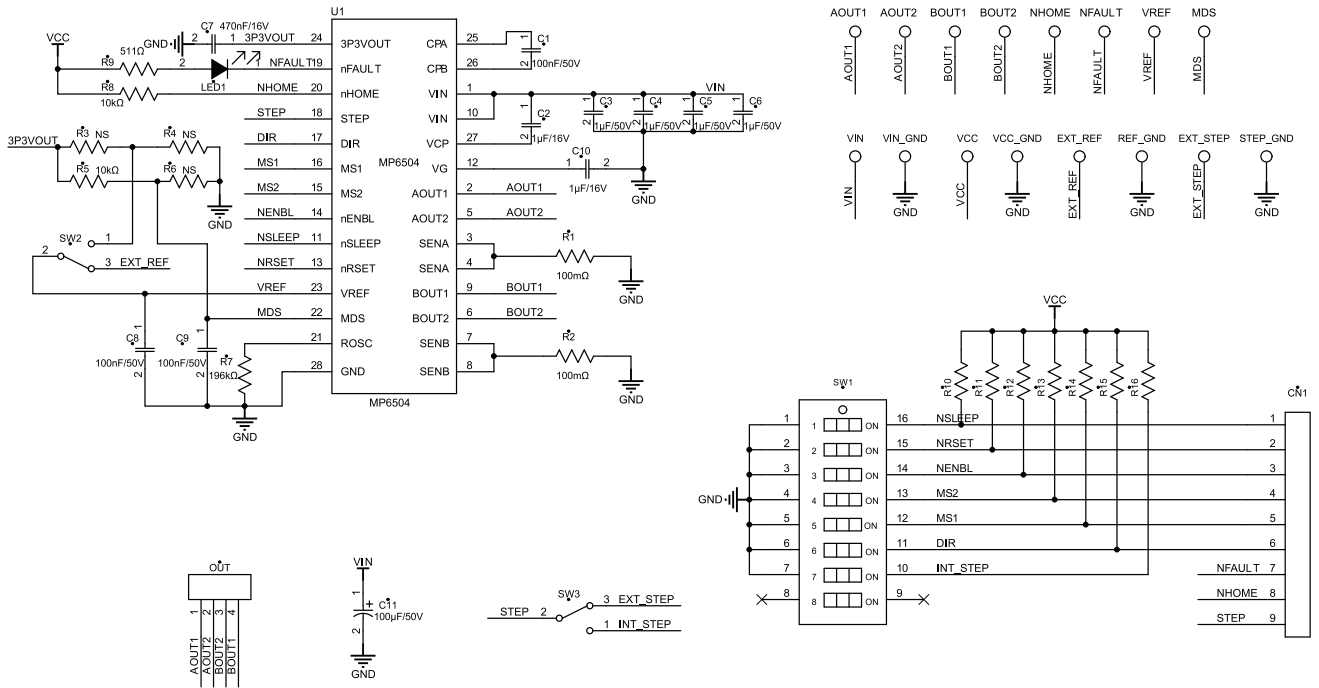

**EV6504-V-00A BILL OF MATERIALS**

Qty	Ref	Value	Description	Package	Manufacturer	Part Number
3	C1, C8, C9	100nF/ 50V	Ceramic capacitor, 50V, X7R	0603	muRata	GRM188R71H104KA93D
2	C2, C10	1µF/ 16V	Ceramic capacitor, 16V, X7R	0603	muRata	GRM188R71C105KA12D
4	C3, C4, C5, C6	1µF/ 50V	Ceramic capacitor, 50V, X7R	0805	muRata	GRM21BR71H105KA12L
1	C7	470nF/ 16V	Ceramic capacitor, 16V, X7R	0603	LION	0603B474K160T
1	C11	100µF/ 50V	Electrolytic capacitor, 50V	DIP	Rubycon	50YXF100MEFC
2	R1, R2	100mΩ	Sense resistor, 1%	2512	CYNTEC	RL3264-9-R100-FN
3	R3, R4, R6	NS				
9	R5, R8, R10, R11, R12, R13, R14, R15, R16	10kΩ	Film resistor, 1%	0603	Yageo	RC0603FR-0710KL
1	R7	196kΩ	Film resistor, 1%	0603	Yageo	RC0603FR-07196KL
1	R9	511Ω	Film resistor, 1%	0603	Yageo	RC0603FR-07511RL
1	LED1	Red	LED	0805	Bai Hong	2012SURC-11
1	SW1	8-bits	Button	SMD	Wurth	418121270808
2	SW2, SW3	SPDT	Button	DIP	Electrical Market	SS-12D01EG4
2	VIN, GND	Φ=2mm	Connector	DIP	Electrical Market	Φ=2mm Needle
10	VCC, VCC_GND, EXT_REF, REF_GND, EXT_STEP, STEP_GND, AOUT1, AOUT2, BOUT1, BOUT2	Φ=1mm	Connector	DIP	Electrical Market	Φ=1mm Needle
4	NHOME, NFAULT, VREF, MDS	Yellow	Test point	DIP	Electrical Market	Test point
1	CN1	9-bits/ 2.54mm	Connector	DIP	Electrical Market	61304011121
1	OUT	4-bits/ 2.54mm	Connector	DIP	Electrical Market	61304011121
1	U1	32V, 2A	Stepper motor driver	QFN-28 (4mmx5mm)	MPS	MP6504GV