



EV6543-L-01A

3V to 12V, Three-Phase Brushless DC Motor Driver Evaluation Board

DESCRIPTION

The EV6543-L-01A is an evaluation board for the MP6543GL, a three-phase, brushless DC motor driver.

The EV6543-L-01A operates from a maximum 12V supply voltage. It integrates three half-bridges consisting of six N-channel power MOSFETs. The rotor position information is provided by the Hall sensors assembled in the motor, and the driving control signals are generated by the external controller, such as an MCU or FPGA.

ELECTRICAL SPECIFICATIONS

Parameter	Symbol	Value	Units
Input voltage	V_{IN}	3 to 12	V
LDO input voltage	V_{IN_LDO}	3 to 12	V
VREF voltage	V_{REF}	3.3	V
VCC voltage	V_{CC}	3.3	V

FEATURES

- Wide 3V to 12V Input Voltage Range
- Built-In 3.3V, 100mA LDO Regulator
- Integrated Bidirectional Current-Sense Amplifiers
- Supports 100% Duty Cycle Operation
- EN/PWM Logic Input
- Over-Current Protection (OCP), Over-Temperature Protection (OTP)
- Fault Indication Output

APPLICATIONS

- Three-Phase Brushless DC Motors and Permanent Magnet Synchronous Motors (PMSMs)
- Drones
- Robotics

All MPS parts are lead-free, halogen-free, and adhere to the RoHS directive. For MPS green status, please visit the MPS website under Quality Assurance. "MPS", the MPS logo, and "Simple, Easy Solutions" are trademarks of Monolithic Power Systems, Inc. or its subsidiaries.

EV6543-L-01A EVALUATION BOARD



(LxW) 6.35cmx6.35cm

Board Number	MPS IC Number
EV6543-L-01A	MP6543GL

QUICK START GUIDE

1. Attach the input voltage ($3V \leq V_{IN} \leq 12V$) to the VIN connector, and attach the input ground to the GND connector.
2. Attach the LDO input voltage ($3V \leq V_{IN_LDO} \leq 12V$) to the VIN_LDO connector, and attach the input ground to the GND connector.
3. Attach a 3.3V constant voltage to the VCC connector, then switch SW1 to position 1 (top side) to enable the chip.
4. To set the current-sense output reference voltage, attach a 3.3V constant voltage to the VREF connector.
5. Attach the motor's Hall signals to the Hall sensor connector.
6. Attach the driving control signals (generated by the external controller) to the CN1 connector.

EVALUATION BOARD SCHEMATIC

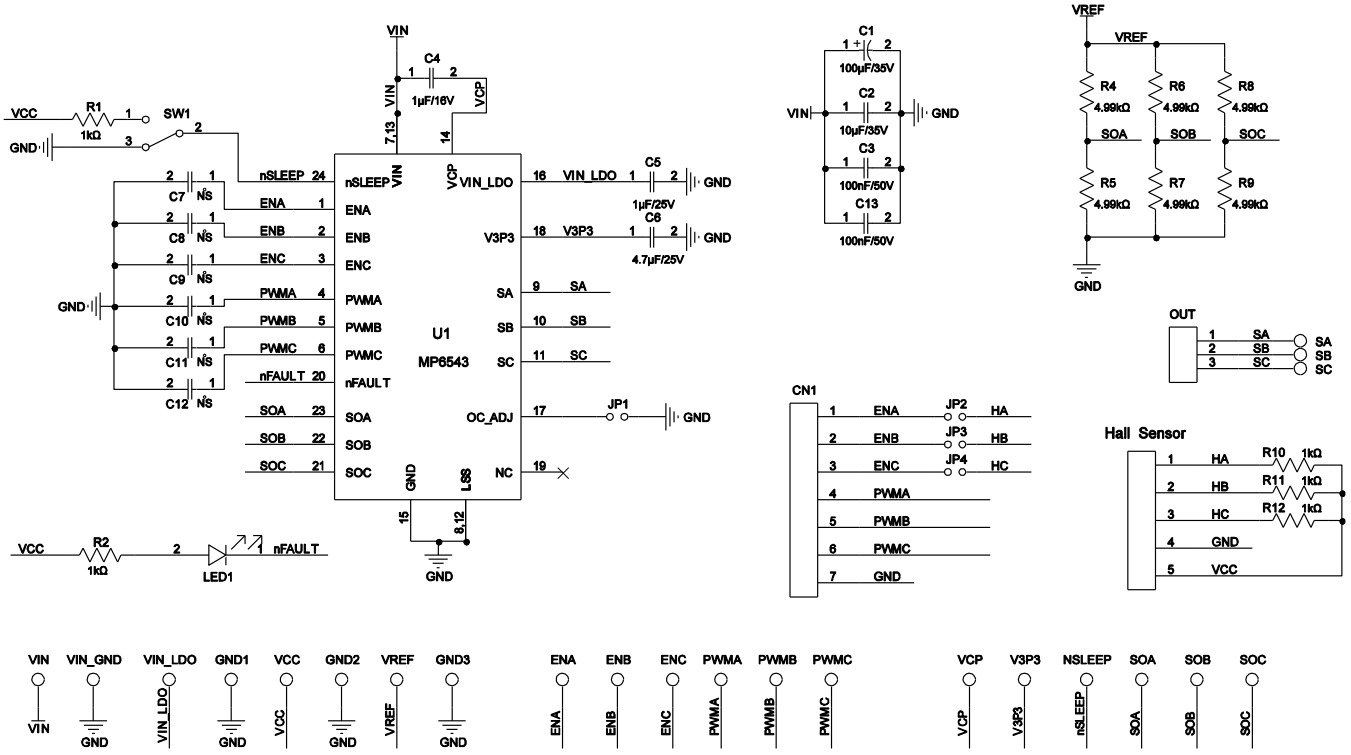

Figure 1: Evaluation Board Schematic

EV6543-L-01A BILL OF MATERIALS

Qty	Ref	Value	Description	Package	Manufacturer	Manufacturer PN
5	R1, R2, R10, R11, R12	1kΩ	Film resistor, 1%	0603	Yageo	RC0603FR-071KL
6	R4, R5, R6, R7, R8, R9	4.99kΩ	Film resistor, 1%	0603	Yageo	RC0603FR-074K99L
1	C1	100μF	Electrolytic capacitor, 35V	DIP	Jianghai	CD287-35V100
1	C2	10μF	Ceramic capacitor, 35V, X7R	1210	Murata	GRM32ER7YA106K A12L
2	C3, C13	100nF	Ceramic capacitor, 50V, X7R	0603	Wurth	885012206095
1	C4	1μF	Ceramic capacitor, 16V, X7R	0603	Wurth	885012206052
1	C5	1μF	Ceramic capacitor, 25V, X5R	0603	Wurth	885012106022
1	C6	4.7μF	Ceramic capacitor, 25V, X5R	0603	Murata	GRM188R61E475KE 11D
6	C7, C8, C9, C10, C11, C12	NS				
1	LED1	Red	LED	0805	Baihong	BL-HUE35A-AV-TRB
1	U1	MP6543	12V, 2A, three-phase BLDC motor driver	QFN-24 (3mmx4mm)	MPS	MP6543GL
1	SW1	SPDT	Button	DIP	Wurth	450301014042
4	JP1, JP2, JP3, JP4	2 bits/ 2.54mm	Connector	DIP	Any	
1	JP1	2 bits/ 2.54mm	Short jumper	DIP	Any	
1	CN1	7 bits/ 2.54mm	Connector	DIP	Any	
1	Hall sensor	5 bits/ 2.54mm	Connector	DIP	Any	
1	PWMA, PWMB, PWMC, ENA, ENB, ENC	6 bits/ 2.54mm	Connector	DIP	Any	
1	OUT	3 bits/ 2.54mm	Connector	DIP	Any	
6	VCP, V3P3, SOA, SOB, SOC, NSLEEP	Yellow	Test point	DIP	Any	
2	VIN, VIN_GND	Φ = 2mm	Connector, Φ = 2mm needle	DIP	Any	
9	VIN_LDO, VREF, VCC, GND, GND, GND, SA, SB, SC	Φ = 1mm	Connector, Φ = 1mm needle	DIP	Any	

PCB LAYOUT

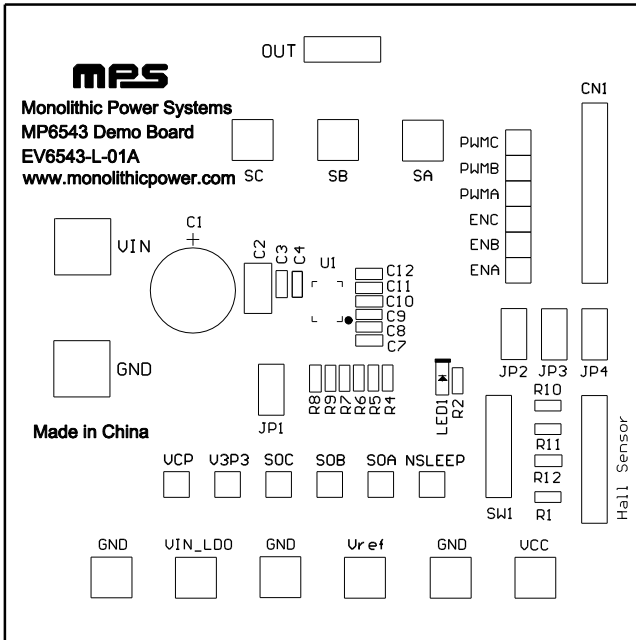

Figure 2: Top Silk Layer

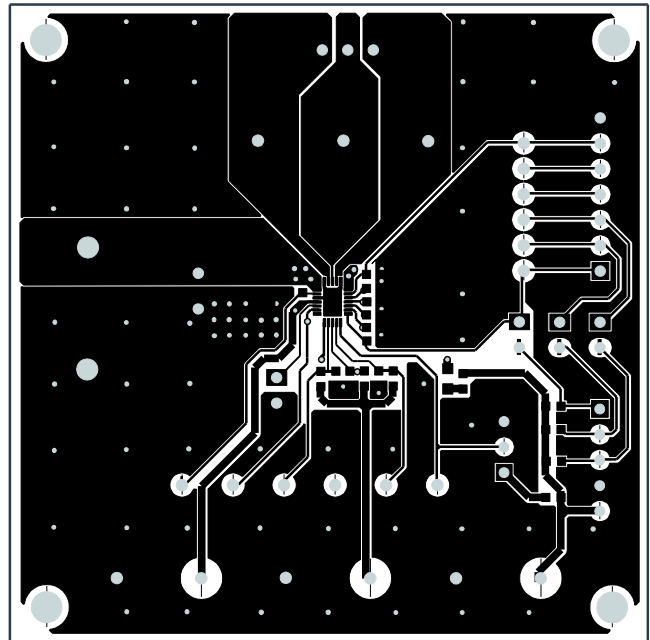

Figure 3: Top Layer

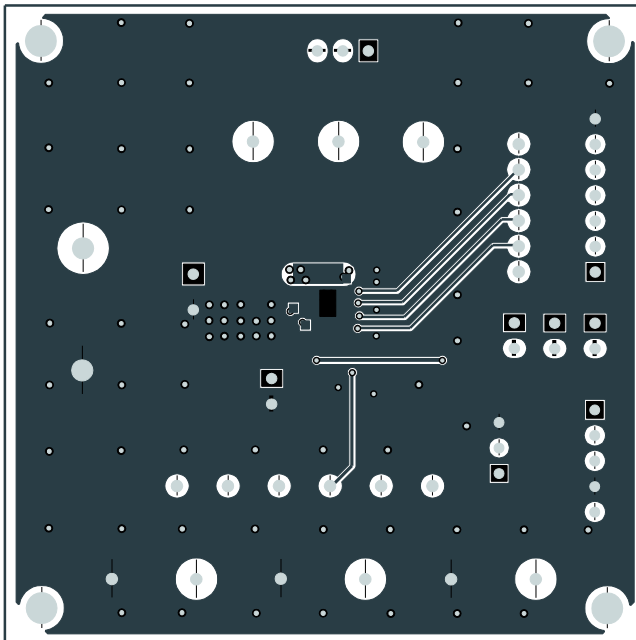

Figure 4: Bottom Layer

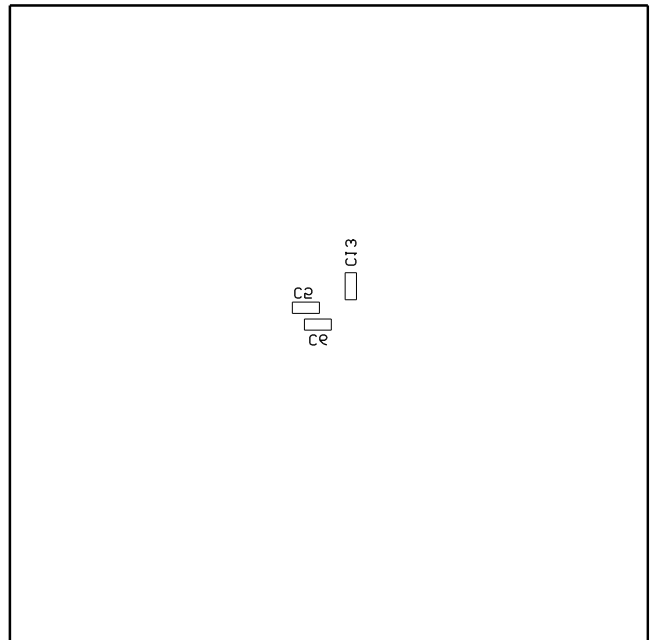

Figure 5: Bottom Silk Layer