

DESCRIPTION

The EV9218-GT-00A is an evaluation board designed to demonstrate the performance of the MP9218, a high-performance regulated charge pump converter. This board is a fully assembled and tested PCB. Its input voltage ranges from 2.8V to V_{OUT} , and its output voltage is regulated to a fixed 5V.

No external inductor is required, which provides additional simplicity and compactness. Internal soft-start circuitry effectively reduces the inrush current during start-up and while the device changes modes.

The MP9218 is a compact system solution, and is available in a TQFN-6 (2mmx2mm) package.

ELECTRICAL SPECIFICATIONS

Parameter	Symbol	Value	Units
Input voltage	V_{IN}	2.8 to V_{OUT}	V
Output voltage	V_{OUT}	5	V

FEATURES

- Input Voltage Range: 2.8V to V_{OUT}
- Internal Soft Start
- Output Maximum Current up to 110mA
- Fixed 5V Output Voltage with 30mV Ripple
- 2x Charge Pump
- Fixed 1MHz Switching Frequency
- Over-Current Protection (OCP)
- Short-Circuit Protection (SCP)
- Inrush Current Limit
- Fully Assembled and Tested
- Available in a TQFN-6 (2mmx2mm) Package

APPLICATIONS

- Cell Phones, Smartphones, LED Backlights
- PDAs or Handheld Computers
- Cameras, Flash White LEDs
- LCD Display Supplies
- TV Remote Controls

All MPS parts are lead-free, halogen-free, and adhere to the RoHS directive. For MPS green status, please visit the MPS website under Quality Assurance. "MPS", the MPS logo, and "Simple, Easy Solutions" are trademarks of Monolithic Power Systems, Inc. or its subsidiaries.

EV9218-GT-00A EVALUATION BOARD

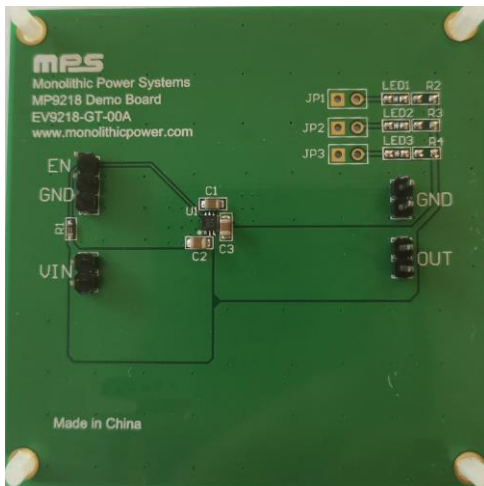

(LxW) 6.35cmx6.35cm

Board Number	MPS IC Number
EV9218-GT-00A	MP9218DG

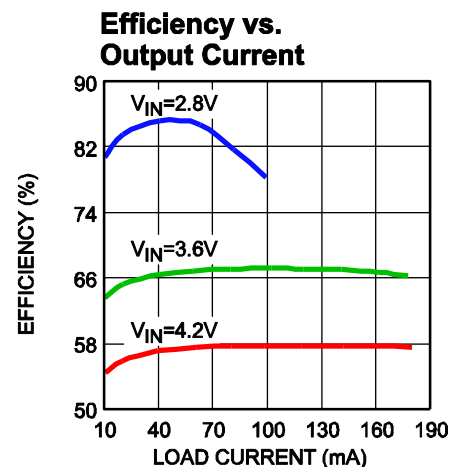

QUICK START GUIDE

1. Connect the load terminals to:
 - a. Positive (+): VOUT
 - b. Negative (-): GND
2. Connect the power supply output terminals to:
 - a. Positive (+): VIN
 - b. Negative (-): GND
3. Preset the power supply output between 2.8V and 5V, then turn the power supply off.
4. Turn the power supply on. The EV9218-GT-00A should automatically start up.
5. To use the enable function, apply an input to the EN pin. Drive EN above 1.5V to turn the regulator on; drive EN below 0.4V to turn it off.
6. The switching frequency on the board is preset to 1.3MHz.

EVALUATION BOARD SCHEMATIC

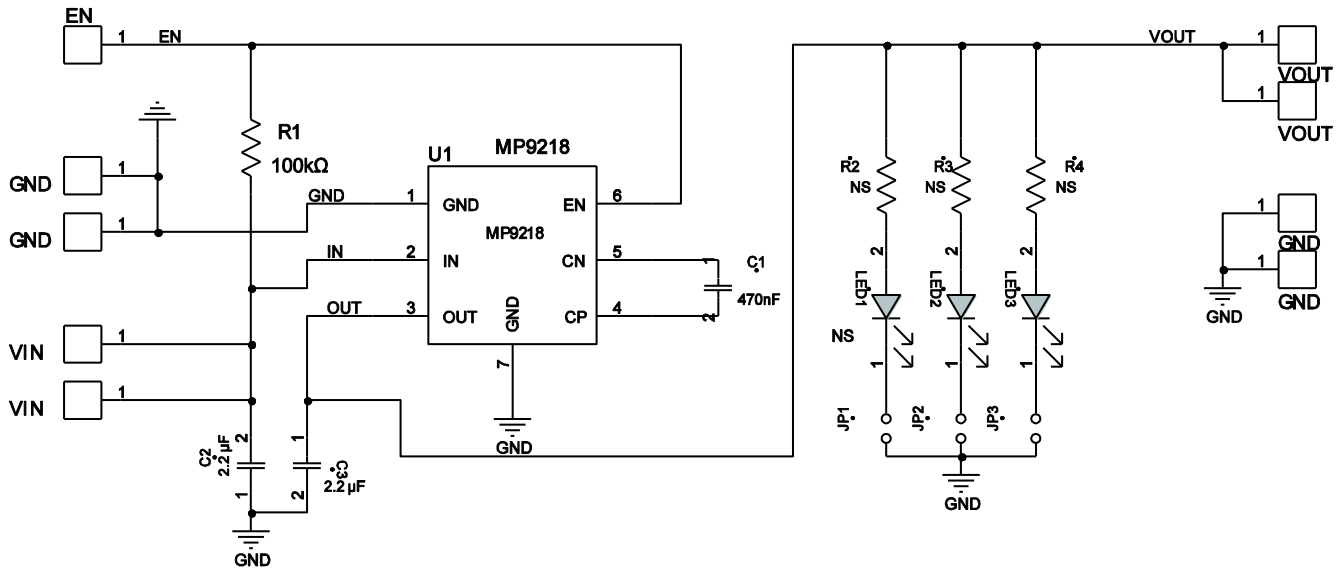

Figure 1: Evaluation Board Schematic

EV9218-GT-00A BILL OF MATERIALS

Qty	Ref	Value	Description	Package	Manufacturer	Manufacturer P/N
1	C1	470nF	Ceramic capacitor, 16V, X7R, 0805	0805	Murata	GRM219R71C474KA0 1D
2	C2, C3	2.2μF	Ceramic capacitor, 50V, X5R	0805	Murata	GRM21BR61C225KA8 8L
1	R1	100kΩ	Film resistor, 1%	0603	Yageo	RC0603FR-0710RL
3	R2, R3, R4	NC	Film resistor, 5%	0603		
3	LED1, LED2, LED3	NC				
3	JP1, JP2, JP3	NC				
1	U1	MP9218	Regulated charge pump converter	TQFN-6 (2mmx2mm)	MPS	MP9218DGT-LF-Z
9	TP1-TP5	VIN, EN, VOUT, GND	TP	Straight Line		

PCB LAYOUT

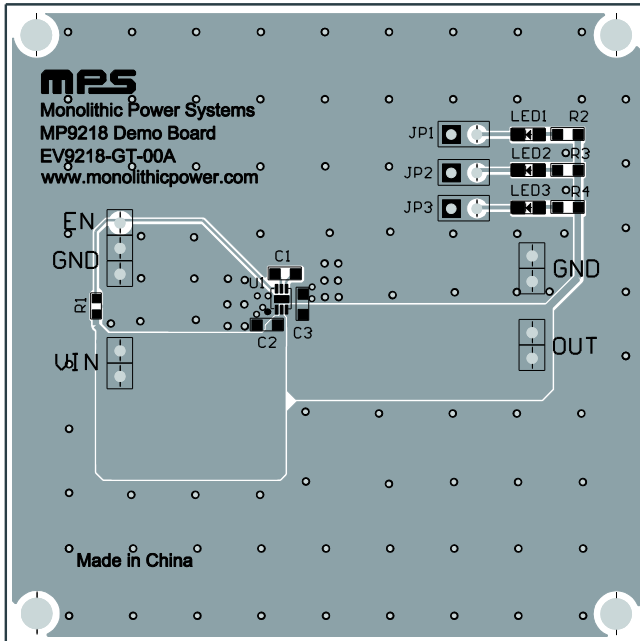

Figure 2: Top Layer

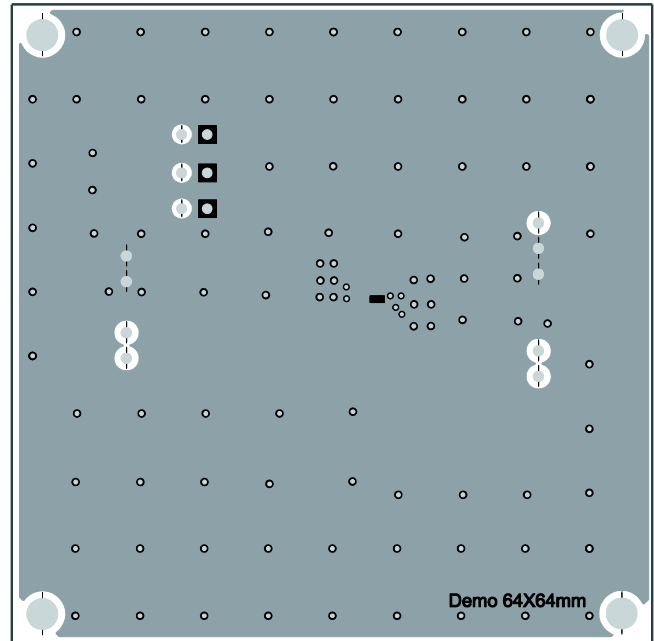

Figure 3: Bottom Layer