



Single Supply, 24-Bit, Sigma-Delta ADC with ± 10 V and 0 mA to 20 mA Inputs, Open Wire Detection

Data Sheet

AD4111

FEATURES

Tested for robustness per: IEC6100-4-2, IEC6100-4-3, IEC6100-4-4, IEC6100-4-5, IEC6100-4-6, CISPR 11

24-bit ADC with integrated analog front end

Fast and flexible output rate: 1.25 SPS to 31.25 kSPS

**Channel scan data rate of 6.21 kSPS per channel
(161 μ s settling)**

16 noise free bits at 1 kSPS per channel

85 dB rejection of 50 Hz and 60 Hz at 20 SPS per channel

± 10 V inputs, 4 differential or 8 single-ended

Pin absolute maximum rating ± 50 V

Absolute input pin voltage up to ± 20 V

≥ 1 M Ω impedance

$\pm 0.06\%$ accuracy at 25°C

Open wire detection

0 mA to 20 mA inputs, 4 single-ended

Pin absolute maximum rating ± 50 mA

Input range from -0.5 mA to $+24$ mA

60 Ω impedance

$\pm 0.08\%$ accuracy at 25°C

On-chip 2.5 V reference

$\pm 0.12\%$ accuracy at 25°C, ± 5 ppm/°C (typical) drift

Internal or external clock

Power supplies

AVDD = 3.0 V to 5.5 V

IOVDD = 2 V to 5.5 V

Total I_{DD} = 3.9 mA

Temperature range: -40 °C to $+105$ °C

3-wire or 4-wire serial digital interface (Schmitt trigger on SCLK)

SPI, QSPI, MICROWIRE, and DSP compatible

APPLICATIONS

Process control

PLC and DCS modules

Instrumentation and measurement

GENERAL DESCRIPTION

The AD4111¹ is a low power, low noise, 24-bit, sigma-delta (Σ - Δ) analog-to-digital converter (ADC) that integrates an analog front end (AFE) for fully differential or single-ended, high impedance (≥ 1 M Ω) bipolar, ± 10 V voltage inputs, and 0 mA to 20 mA current inputs.

The AD4111 also integrates key analog and digital signal conditioning blocks to configure eight individual setups for each analog input channel in use. The AD4111 features a maximum channel scan rate of 6.21 kSPS (161 μ s) for fully settled data.

The embedded 2.5 V, low drift (5 ppm/°C), band gap internal reference (with output reference buffer) reduces the external component count.

The digital filter allows flexible settings, including simultaneous 50 Hz and 60 Hz rejection at a 27.27 SPS output data rate. The user can select between the different filter settings depending on the demands of each channel in the application. The automatic channel sequencer enables the ADC to switch through each enabled channel.

The precision performance of the AD4111 is achieved by integrating the proprietary *iPassives*[™] technology from Analog Devices, Inc. The AD4111 is factory calibrated to achieve a high degree of specified accuracy.

The AD4111 also has the unique feature of open wire detection on the voltage inputs for system level diagnostics using a single 5 V or 3.3 V power supply.

The AD4111 operates with a single power supply, making it easy to use in galvanically isolated applications. The specified operating temperature range is -40 °C to $+105$ °C. The AD4111 is housed in a 40-lead, 6 mm \times 6 mm LFCSP package.

¹Protected by U.S. Patent 10,852,360.

Rev. B

[Document Feedback](#)

Information furnished by Analog Devices is believed to be accurate and reliable. However, no responsibility is assumed by Analog Devices for its use, nor for any infringements of patents or other rights of third parties that may result from its use. Specifications subject to change without notice. No license is granted by implication or otherwise under any patent or patent rights of Analog Devices. Trademarks and registered trademarks are the property of their respective owners.

One Technology Way, P.O. Box 9106, Norwood, MA 02062-9106, U.S.A.
Tel: 781.329.4700 ©2018–2021 Analog Devices, Inc. All rights reserved.
[Technical Support](#) www.analog.com

TABLE OF CONTENTS

Features.....	1	CRC Calculation.....	40
Applications	1	Integrated Functions.....	42
General Description.....	1	General-Purpose Outputs.....	42
Revision History	3	Delay	42
Functional Block Diagram	4	16-Bit/24-Bit Conversions	42
Specifications	5	DOUT_RESET	42
Timing Characteristics	8	Synchronization	42
Absolute Maximum Ratings	10	Error Flags.....	43
Thermal Resistance	10	DATA_STAT.....	43
ESD Caution.....	10	IOSTRENGTH	43
Pin Configuration and Function Descriptions	11	Internal Temperature Sensor	43
Typical Performance Characteristics.....	13	Applications Information	44
Noise Performance and Resolution	18	IEC61000-4-x and CISPR 11 Robustness	44
Theory of Operation	20	Grounding and Layout.....	44
Power Supplies.....	21	Register Summary	45
Digital Communication	21	Register Details	47
AD4111 Reset.....	22	Communications Register	47
Configuration Overview.....	23	Status Register.....	48
Circuit Description.....	26	ADC Mode Register.....	49
Multiplexer	26	Interface Mode Register	50
Current Inputs	27	Register Check.....	51
Voltage Inputs.....	27	Data Register.....	51
Data Output Coding	29	GPIO Configuration Register.....	52
AD4111 Reference.....	29	ID Register	53
Buffered Reference Input	30	Channel Register 0	53
Clock Source	30	Channel Register 1 to Channel Register 15.....	54
Digital Filter	31	Setup Configuration Register 0.....	55
Sinc5 + Sinc1 Filter	31	Setup Configuration Register 1 to Setup Configuration Register 7	55
Sinc3 Filter.....	31	Filter Configuration Register 0	56
Single Cycle Settling.....	32	Filter Configuration Register 1 to Filter Configuration Register 7	57
Enhanced 50 Hz and 60 Hz Rejection Filters.....	32	Offset Register 0	57
Operating Modes.....	35	Offset Register 1 to Offset Register 7.....	57
Continuous Conversion Mode.....	35	Gain Register 0	58
Continuous Read Mode	36	Gain Register 1 to Gain Register 7.....	58
Single Conversion Mode	37	Outline Dimensions.....	59
Standby and Power-Down Modes	38	Ordering Guide	59
Calibration.....	38		
Digital Interface	39		
Checksum Protection	39		

REVISION HISTORY

3/2021—Rev. A to Rev. B

Changes to Features Section..... 1
Added Patent Note, Note 1..... 1
Changes to Table 6 and Table 718
Changes to Table 8 and Table 919
Changes to Table 36.....56

2/2019—Rev. 0 to Rev. A

Change to Product Title 1
Changes to Features Section and Applications Section..... 1
Changes to Table 1.....5
Changes to Figure 1013
Changed 180 pF to 680 pF28
Added IEC61000-4-x and CISPR 11 Robustness Section44

8/2018—Revision 0: Initial Version

FUNCTIONAL BLOCK DIAGRAM

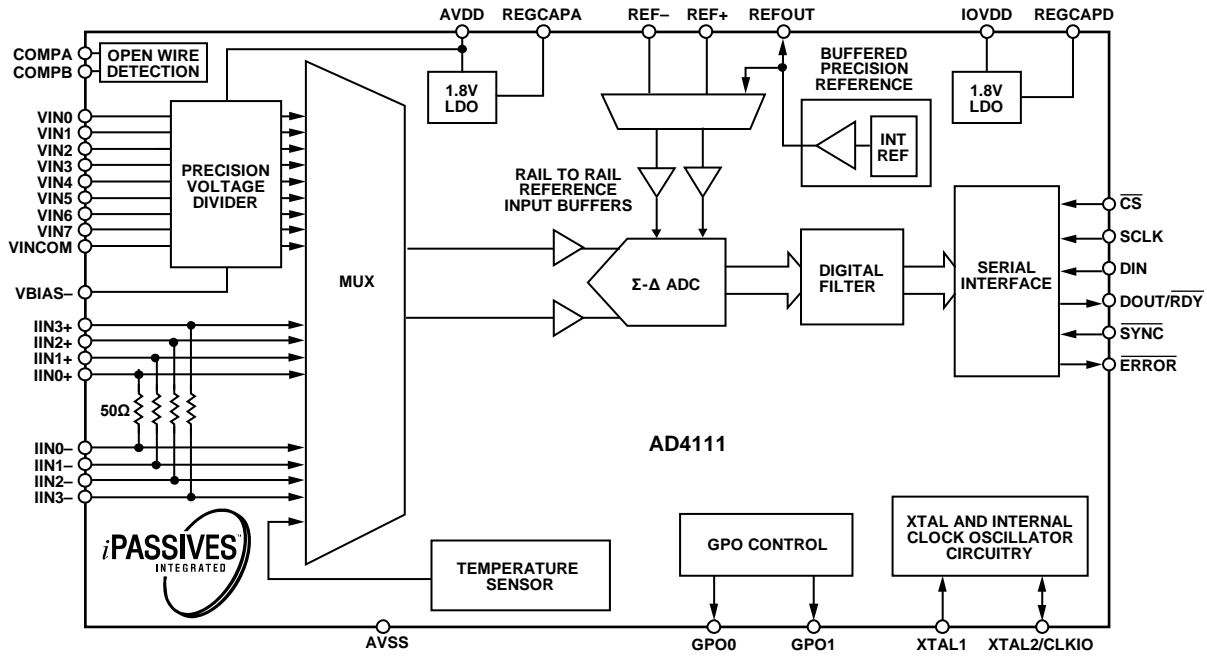

Figure 1.

18640-001

SPECIFICATIONS

AVDD = 3.0 V to 5.5 V, IOVDD = 2 V to 5.5 V, AVSS = 0 V, DGND = 0 V, VBIAS- = 0 V, REF+ = 2.5 V, REF- = AVSS, internal master clock (MCLK) = 2 MHz, T_A = T_{MIN} to T_{MAX} (-40°C to +105°C), unless otherwise noted.

Table 1.

Parameter	Test Conditions/Comments	Min	Typ	Max	Unit
VOLTAGE INPUTS					
Differential Input Voltage Range ¹	Specified performance	-10		+10	V
	Functional	-V _{REF} × 10		+V _{REF} × 10	V
Absolute (Pin) Input Voltage	AVDD ≥ 4.75 V	-20		+20	V
	AVDD = 3.0 V	-12		+12	V
Input Impedance		1			MΩ
Offset Error ²	25°C		±1.5		mV
Offset Drift			±7		μV/°C
Gain Error	Internal full-scale calibration ³ , 25°C		±0.05		% of FSR
Gain Drift			±1		ppm/°C
Integral Nonlinearity (INL)			±0.01		% of FSR
Total Unadjusted Error (TUE) ⁴	Internal full-scale calibration				
	25°C, internal V _{REF}			±0.06	% of FSR
	-40°C to +105°C, internal V _{REF}			±0.1	% of FSR
	25°C, external V _{REF}			±0.06	% of FSR
	-40°C to +105°C, external V _{REF}			±0.08	% of FSR
Power Supply Rejection	AVDD for V _{IN} = 1 V		70		dB
Common-Mode Rejection	V _{IN} = 1 V				
At DC			85		dB
At 50 Hz, 60 Hz	20 Hz output data rate (postfilter), 50 Hz ± 1 Hz and 60 Hz ± 1 Hz		120		dB
Normal Mode Rejection ⁴	50 Hz ± 1 Hz and 60 Hz ± 1 Hz				
	Internal clock, 20 SPS ODR (postfilter)	71	90		dB
	External clock, 20 SPS ODR (postfilter)	85	90		dB
Resolution	See Table 6 and Table 8				
Noise	See Table 6 and Table 8				
CURRENT INPUTS					
Input Current Range		-0.5		+24	mA
Absolute (Pin) Input Voltage		AVSS - 0.05		AVDD + 0.05 ⁵	V
Input Impedance ⁶		54	60	75	Ω
Offset Error ²			±2		μA
Offset Drift			±3		nA/°C
Gain Error	Factory calibrated gain, 25°C		±0.02		% of FSR
Gain Drift			±10		ppm/°C
INL			±0.01		% of FSR
TUE ⁴	25°C, internal V _{REF}			±0.08	% of FSR
	-40°C to +105°C, internal V _{REF}			±0.2	% of FSR
	25°C, external V _{REF}			±0.08	% of FSR
	-40°C to +105°C, external V _{REF}			±0.2	% of FSR
Power Supply Rejection	AVDD for I _{IN} = 10 mA		0.5		μA/V
Normal Mode Rejection ⁴	50 Hz ± 1 Hz and 60 Hz ± 1 Hz				
	Internal clock, 20 SPS ODR (postfilter)	71	90		dB
	External clock, 20 SPS ODR (postfilter)	85	90		dB
Resolution	See Table 7 and Table 9				
Noise	See Table 7 and Table 9				
ADC SPEED AND PERFORMANCE					
ADC Output Data Rate (ODR)	One channel, see Table 6	1.25		31,250	SPS
No Missing Codes ⁴	Excluding sinc3 filter ≥ 15 kHz notch	24			Bits

Parameter	Test Conditions/Comments	Min	Typ	Max	Unit
INTERNAL REFERENCE	100 nF external capacitor to AVSS				
Output Voltage	REFOUT with respect to AVSS		2.5		V
Initial Accuracy ^{4, 7}	REFOUT, T _A = 25°C	-0.12		+0.12	% of V
Temperature Coefficient			±5	+12	ppm/°C
Reference Load Current, I _{LOAD}		-10		+10	mA
Power Supply Rejection	AVDD (line regulation)		95		dB
Load Regulation	$\Delta V_{OUT}/\Delta I_{LOAD}$		32		ppm/mA
Voltage Noise	e _N , 0.1 Hz to 10 Hz, 2.5 V reference		4.5		μV rms
Voltage Noise Density	e _N , 1 kHz, 2.5 V reference		215		nV/√Hz
Turn On Settling Time	100 nF REFOUT capacitor		200		μs
Short-Circuit Current, I _{SC}			25		mA
EXTERNAL REFERENCE INPUTS					
Differential Input Range	V _{REF} = (REF+) – (REF–)	1	2.5	AVDD	V
Absolute Voltage Limits					
Buffers Disabled		AVSS – 0.05		AVDD + 0.05	V
Buffers Enabled		AVSS		AVDD	V
REF± Input Current					
Buffers Disabled					
Input Current			±9		μA/V
Input Current Drift	External clock		±0.75		nA/V/°C
	Internal clock		±2		nA/V/°C
Buffers Enabled					
Input Current			±100		nA
Input Current Drift			0.25		nA/°C
Normal Mode Rejection	See the rejection parameter				
Common-Mode Rejection			95		dB
TEMPERATURE SENSOR					
Accuracy	After user calibration at 25°C		±2		°C
Sensitivity			477		μV/K
GENERAL-PURPOSE OUTPUTS (GPO0, GPO1)	With respect to AVSS				
Floating State Output Capacitance			5		pF
Output Voltage ⁴					
High, V _{OH}	Source current (I _{SOURCE}) = 200 μA	AVDD – 1			V
Low, V _{OL}	Sink current (I _{SINK}) = 800 μA			AVSS + 0.4	V
CLOCK					
Internal Clock					
Frequency			2		MHz
Accuracy		-2.5%		+2.5%	%
Duty Cycle			50		%
Output Voltage					
Low, V _{OL}				0.4	V
High, V _{OH}		0.8 × IOVDD			V
Crystal					
Frequency		14	16	16.384	MHz
Start-Up Time			10		μs
External Clock (CLKIO)					
Duty Cycle		30	50	70	%

Parameter	Test Conditions/Comments	Min	Typ	Max	Unit
LOGIC INPUTS					
Input Voltage ⁴	High, V_{INH}	$2\text{ V} \leq \text{IOVDD} < 2.3\text{ V}$			V
		$2.3\text{ V} \leq \text{IOVDD} \leq 5.5\text{ V}$			V
Low, V_{INL}		$2\text{ V} \leq \text{IOVDD} < 2.3\text{ V}$		$0.35 \times \text{IOVDD}$	V
		$2.3\text{ V} \leq \text{IOVDD} \leq 5.5\text{ V}$		0.7	V
Hysteresis ⁴		$\text{IOVDD} \geq 2.7\text{ V}$	0.08	0.25	V
		$\text{IOVDD} < 2.7\text{ V}$	0.04	0.2	V
Leakage Current		-10		+10	μA
LOGIC OUTPUT (DOUT/RDY)					
Output Voltage	High, V_{OH}	$\text{IOVDD} \geq 4.5\text{ V}, I_{SOURCE} = 1\text{ mA}$	$0.8 \times \text{IOVDD}$		V
		$2.7\text{ V} \leq \text{IOVDD} < 4.5\text{ V}, I_{SOURCE} = 500\text{ }\mu\text{A}$	$0.8 \times \text{IOVDD}$		V
		$\text{IOVDD} < 2.7\text{ V}, I_{SOURCE} = 200\text{ }\mu\text{A}$	$0.8 \times \text{IOVDD}$		V
Low, V_{OL}		$\text{IOVDD} \geq 4.5\text{ V}, I_{SINK} = 2\text{ mA}$		0.4	V
		$2.7\text{ V} \leq \text{IOVDD} < 4.5\text{ V}, I_{SINK} = 1\text{ mA}$		0.4	V
		$\text{IOVDD} < 2.7\text{ V}, I_{SINK} = 400\text{ }\mu\text{A}$		0.4	V
Leakage Current	Floating state	-10		+10	μA
Output Capacitance	Floating state		10		pF
POWER REQUIREMENTS					
Power Supply Voltage					
AVDD to AVSS		3.0		5.5	V
AVSS to DGND		-2.75		0	V
IOVDD to DGND		2		5.5	V
IOVDD to AVSS	For AVSS < DGND			6.35	V
POWER SUPPLY CURRENTS⁸					
	All outputs unloaded, digital inputs connected to IOVDD or DGND				
Full Operating Mode	Including internal reference		3.3	3.7	mA
		AVDD Current			
IOVDD Current	Internal clock		0.6	0.8	mA
Standby Mode	All $V_{IN} = 0\text{ V}$		120		μA
Power-Down Mode	All $V_{IN} = 0\text{ V}$		90		μA
POWER DISSIPATION					
Full Operating Mode			19.5		mW
Standby Mode			600		μW
Power-Down Mode			450		μW

¹ The full specification is guaranteed for a differential input signal of $\pm 10\text{ V}$. The device is functional up to a differential input signal of $\pm V_{REF} \times 10$. However, the specified absolute (pin) voltage must not be exceeded for the proper function.

² Following a system zero-scale calibration, the offset error is in the order of the noise for the programmed output data rate selected.

³ The gain calibration register is overwritten by performing an internal full-scale calibration. Alternatively, a system full-scale calibration reduces the gain error to the order of the noise for the programmed output data rate for the channel that is calibrated.

⁴ Specification is not production tested but is supported by characterization data at the initial product release.

⁵ This maximum specification is only possible if IINx- is biased so that the current through the resistor is less than 24 mA. It is not possible with IINx- connected to 0 V.

⁶ This specification shows the impedance seen between current input pins. The current is measured across a 50 Ω sense resistor.

⁷ This specification includes moisture sensitivity level (MSL) preconditioning effects.

⁸ This specification is with no load on the REFOUT pin and the digital output pins.

TIMING CHARACTERISTICS

IOVDD = 2 V to 5.5 V, DGND = 0 V, Input Logic 0 = 0 V, Input Logic 1 = IOVDD, capacitive load (C_{LOAD}) = 20 pF, unless otherwise noted.

Table 2.

Parameter	Limit at T_{MIN} , T_{MAX}	Unit	Description ^{1, 2}
SCLK			
t_3	25	ns min	SCLK high pulse width
t_4	25	ns min	SCLK low pulse width
READ OPERATION			
t_1	0	ns min	\overline{CS} falling edge to DOUT/ \overline{RDY} active time
	15	ns max	IOVDD = 4.75 V to 5.5 V
	40	ns max	IOVDD = 2 V to 3.6 V
t_2^3	0	ns min	SCLK active edge to data valid delay ⁴
	12.5	ns max	IOVDD = 4.75 V to 5.5 V
	25	ns max	IOVDD = 2 V to 3.6 V
t_5^5	2.5	ns min	Bus relinquish time after \overline{CS} inactive edge
	20	ns max	
t_6	0	ns min	SCLK inactive edge to \overline{CS} inactive edge
t_7	10	ns min	SCLK inactive edge to DOUT/ \overline{RDY} high/low
WRITE OPERATION			
t_8	0	ns min	\overline{CS} falling edge to SCLK active edge setup time ⁴
t_9	8	ns min	Data valid to SCLK edge setup time
t_{10}	8	ns min	Data valid to SCLK edge hold time
t_{11}	5	ns min	\overline{CS} rising edge to SCLK edge hold time

¹ Sample tested during initial release to ensure compliance.

² See Figure 2 and Figure 3.

³ This parameter is defined as the time required for the output to cross the V_{OL} or V_{OH} limits.

⁴ The SCLK active edge is the falling edge of SCLK.

⁵ DOUT/ \overline{RDY} returns high after a read of the data register. In single-conversion mode and continuous conversion mode, the same data can be read again, if required, while DOUT/ \overline{RDY} is high. However, care must be taken to ensure that subsequent reads do not occur close to the next output update. If the continuous read feature is enabled, the digital word can be read only once.

Timing Diagrams

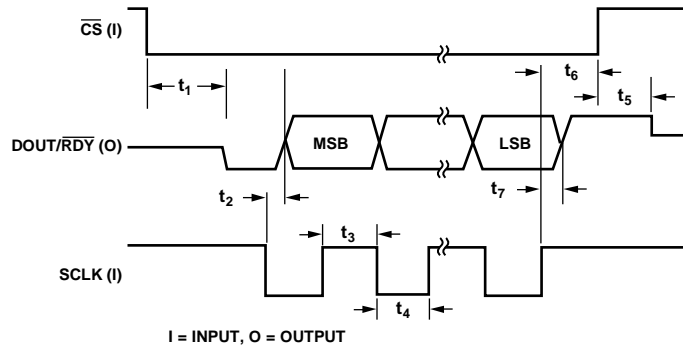

Figure 2. Read Cycle Timing Diagram

1864-0-002

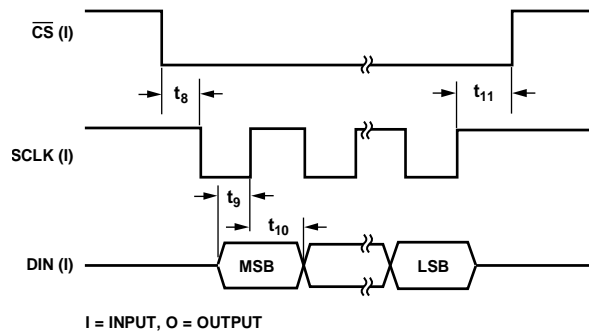

Figure 3. Write Cycle Timing Diagram

1864-0-003

ABSOLUTE MAXIMUM RATINGS

$T_A = 25^\circ\text{C}$, unless otherwise noted.

Table 3.

Parameter	Rating
AVDD to AVSS	-0.3 V to +6.5 V
AVDD to DGND	-0.3 V to +6.5 V
IOVDD to DGND	-0.3 V to +6.5 V
IOVDD to AVSS	-0.3 V to +7.5 V
AVSS to DGND	-3.25 V to +0.3 V
VINx to AVSS	-50 V to +50 V
IINx+ to AVSS	-0.3 V to AVDD + 0.3 V
IINx- to AVSS	-0.3 V to AVDD + 0.3 V
Current Input Current ¹	-50 mA to +50 mA
Reference Input Voltage to AVSS	-0.3 V to AVDD + 0.3 V
Digital Input Voltage to DGND	-0.3 V to IOVDD + 0.3 V
Digital Output Voltage to DGND	-0.3 V to IOVDD + 0.3 V
Digital Input Current	10 mA
Operating Temperature Range	-40°C to +105°C
Storage Temperature Range	-65°C to +150°C
Maximum Junction Temperature	150°C
Lead Soldering, Reflow Temperature	260°C

¹ The absolute maximum current input current, current input voltage, and IINx- voltage must all be within the specified limits.

Stresses at or above those listed under Absolute Maximum Ratings may cause permanent damage to the product. This is a stress rating only; functional operation of the product at these or any other conditions above those indicated in the operational section of this specification is not implied. Operation beyond the maximum operating conditions for extended periods may affect product reliability.

THERMAL RESISTANCE

Thermal performance is directly linked to printed circuit board (PCB) design and operating environment. Careful attention to PCB thermal design is required.

θ_{JA} is specified for a device soldered on a JEDEC test board for surface-mount packages.

Table 4. Thermal Resistance

Package Type	θ_{JA}	Unit
CP-40-15 ¹		
4-Layer JEDEC Board	34	°C/W

¹ Thermal impedance simulated values are based on JEDEC 2S2P thermal test board with 16 thermal vias. See JEDEC JESD51.

ESD CAUTION



ESD (electrostatic discharge) sensitive device. Charged devices and circuit boards can discharge without detection. Although this product features patented or proprietary protection circuitry, damage may occur on devices subjected to high energy ESD. Therefore, proper ESD precautions should be taken to avoid performance degradation or loss of functionality.

PIN CONFIGURATION AND FUNCTION DESCRIPTIONS

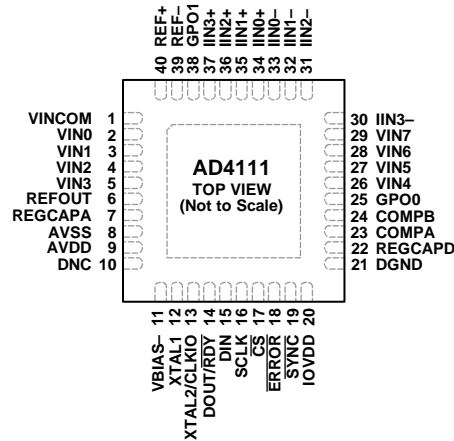

NOTES
 1. DNC = DO NOT CONNECT. DO NOT CONNECT ANYTHING TO THIS PIN.
 2. SOLDER THE EXPOSED PAD TO A SIMILAR PAD ON THE PCB UNDER THE EXPOSED PAD TO CONFER MECHANICAL STRENGTH AND FOR HEAT DISSIPATION. THE EXPOSED PAD MUST BE CONNECTED TO AVSS THROUGH THIS PAD ON THE PCB.

16640-004

Figure 4. Pin Configuration

Table 5. Pin Function Descriptions

Pin No.	Mnemonic ¹	Type ²	Description
1	VINCOM	AI	Voltage Input Common. Voltage inputs are referenced to this pin when configured as single-ended. Connect this pin to analog ground.
2	VIN0	AI	Voltage Input 0. Input referenced to VINCOM in single-ended configuration, or a positive input of an input pair with VIN1 in differential configuration.
3	VIN1	AI	Voltage Input 1. Input referenced to VINCOM in single-ended configuration, or a negative input of an input pair with VIN0 in differential configuration.
4	VIN2	AI	Voltage Input 2. Input referenced to VINCOM in single-ended configuration, or a positive input of an input pair with VIN3 in differential configuration.
5	VIN3	AI	Voltage Input 3. Input referenced to VINCOM in single-ended configuration, or a negative input of an input pair with VIN2 in differential configuration.
6	REFOUT	AO	Buffered Output of Internal Reference. The output is 2.5 V with respect to AVSS. Decouple this pin to AVSS using a 0.1 μF capacitor.
7	REGCAPA	AO	Analog Low Dropout (LDO) Regulator Output. Decouple this pin to AVSS using a 1 μF capacitor and a 0.1 μF capacitor.
8	AVSS	P	Negative Analog Supply. This supply ranges from –2.75 V to 0 V and is nominally set to 0 V.
9	AVDD	P	Analog Supply Voltage. This voltage ranges from 3.0 V to 5.5 V with respect to AVSS.
10	DNC	N/A	Do Not Connect. Do not connect anything to this pin.
11	VBIAS–	AI	Voltage Bias Negative. The pin is setting bias voltage for the voltage input analog front-end. Connect this pin to AVSS.
12	XTAL1	AI	Input 1 for Crystal.
13	XTAL2/CLKIO	AI/DI	Input 2 for Crystal/Clock Input or Output. See the CLOCKSEL bit settings in the ADCMODE register for more information.
14	DOUT/ $\overline{\text{RDY}}$	DO	Serial Data Output/Data Ready Output. This pin serves a dual purpose. It functions as a serial data output pin to access the output shift register of the ADC. The output shift register can contain data from any of the on-chip data or control registers. The data-word/control word information is placed on the DOUT/ $\overline{\text{RDY}}$ pin on the SCLK falling edge and is valid on the SCLK rising edge. When $\overline{\text{CS}}$ is high, the DOUT/ $\overline{\text{RDY}}$ output is tristated. When $\overline{\text{CS}}$ is low, and a register is not being read, DOUT/ $\overline{\text{RDY}}$ operates as a data ready pin, going low to indicate the completion of a conversion. If the data is not read after the conversion, the pin goes high before the next update occurs. The DOUT/ $\overline{\text{RDY}}$ falling edge can be used as an interrupt to a processor, indicating that valid data is available.
15	DIN	DI	Serial Data Input to the Input Shift Register on the ADC. Data in this shift register is transferred to the control registers in the ADC, with the register address (RA) bits of the communications register identifying the appropriate register. Data is clocked in on the rising edge of SCLK.

Pin No.	Mnemonic ¹	Type ²	Description
16	SCLK	DI	Serial Clock Input. This serial clock input is for data transfers to and from the ADC. SCLK has a Schmitt triggered input.
17	$\overline{\text{CS}}$	DI	Chip Select Input. This pin is an active low logic input used to select the ADC. Use $\overline{\text{CS}}$ to select the ADC in systems with more than one device on the serial bus. $\overline{\text{CS}}$ can be hardwired low, allowing the ADC to operate in 3-wire mode with SCLK, DIN, and DOUT/RDY used to interface with the device. When $\overline{\text{CS}}$ is high, the DOUT/RDY output is tristated.
18	$\overline{\text{ERROR}}$	DI/O	Error Input/Output or General-Purpose Output. This pin can be used in one of the following three modes: Active low error input mode. This mode sets the ADC_ERROR bit in the status register. Active low, open-drain error output mode. The status register error bits are mapped to the $\overline{\text{ERROR}}$ pin. The $\overline{\text{ERROR}}$ pins of multiple devices can be wired together to a common pull-up resistor so that an error on any device can be observed. General-purpose output mode. The status of the pin is controlled by the ERR_DAT bit in the GPIOCON register. The pin is referenced between IOVDD and DGND.
19	$\overline{\text{SYNC}}$	DI	Synchronization Input. Allows synchronization of the digital filters and analog modulators when using multiple AD4111 devices.
20	IOVDD	P	Digital I/O Supply Voltage. The IOVDD voltage ranges from 2 V to 5.5 V (nominal). IOVDD is independent of AVDD. For example, IOVDD can be operated at 3.3 V when AVDD equals 5 V, or vice versa. If AVSS is set to -2.5 V, the voltage on IOVDD must not exceed 3.6 V.
21	DGND	P	Digital Ground.
22	REGCAPD	AO	Digital LDO Regulator Output. This pin is for decoupling purposes only. Decouple this pin to DGND using a 1 μF capacitor.
23	COMP A	AO	Compensation Pin for VIN0, VIN2, VIN4, and VIN6. Connect this pin to the corresponding voltage input pins through a 1 k Ω resistor and 680 pF capacitor when using open wire detection (see the Open Wire Detection section).
24	COMP B	AO	Compensation Pin for VIN1, VIN3, VIN5, and VIN7. Connect this pin to the corresponding voltage input pins through a 1 k Ω resistor and 680 pF capacitor when using open wire detection (see the Open Wire Detection section).
25	GPO0	DO	General-Purpose Output. Logic output on this this pin is referred to the AVDD and AVSS supplies.
26	VIN4	AI	Voltage Input 4. Input referenced to VINCOM in single-ended configuration, or a positive input of an input pair with VIN5 in differential configuration.
27	VIN5	AI	Voltage Input 5. Input referenced to VINCOM in single-ended configuration, or a negative input of an input pair with VIN4 in differential configuration.
28	VIN6	AI	Voltage Input 6. Input referenced to VINCOM in single-ended configuration, or a positive input of an input pair with VIN7 in differential configuration.
29	VIN7	AI	Voltage Input 7. Input referenced to VINCOM in single-ended configuration, or a negative input of an input pair with VIN6 in differential configuration.
30	IIN3-	AI	Current Input Return 3. Connect this pin to analog ground.
31	IIN2-	AI	Current Input Return 2. Connect this pin to analog ground.
32	IIN1-	AI	Current Input Return 1. Connect this pin to analog ground.
33	IIN0-	AI	Current Input Return 0. Connect this pin to analog ground.
34	IIN0+	AI	Current Input 0.
35	IIN1+	AI	Current Input 1.
36	IIN2+	AI	Current Input 2.
37	IIN3+	AI	Current Input 3.
38	GPO1	DO	General-Purpose Output. Logic output on this pin is referred to the AVDD and AVSS supplies.
39	REF-	AI	Reference Input Negative Terminal. REF- can span from AVSS to AVDD - 1 V. Reference can be selected through the REF_SELx bits in the setup configuration registers.
40	REF+	AI	Reference Input Positive Terminal. An external reference can be applied between REF+ and REF-. REF+ can span from AVDD to AVSS + 1 V. Reference can be selected through the REF_SELx bits in the setup configuration registers.
	EP	P	Exposed Pad. Solder the exposed pad to a similar pad on the PCB under the exposed pad to confer mechanical strength to the package and for heat dissipation. The exposed pad must be connected to AVSS through this pad on the PCB.

¹ Note that, throughout this data sheet, the dual function pin mnemonics are referenced by the relevant function only.

² AI means analog input, AO means analog output, P means power supply, N/A means not applicable, DI means digital input, DO means digital output, and DI/O means bidirectional digital input/output.

TYPICAL PERFORMANCE CHARACTERISTICS

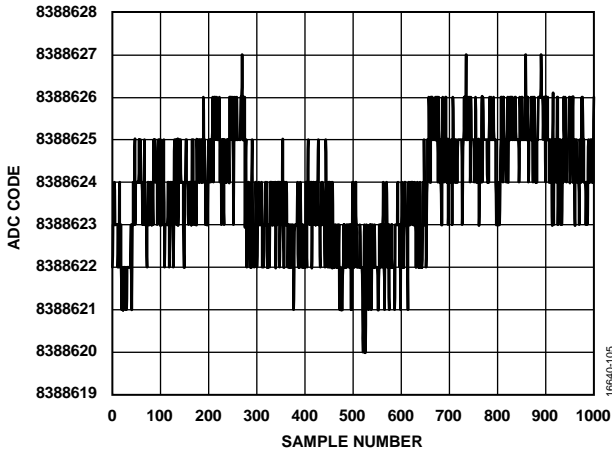

Figure 5. Noise (Voltage Input, Output Data Rate = 1.25 SPS)

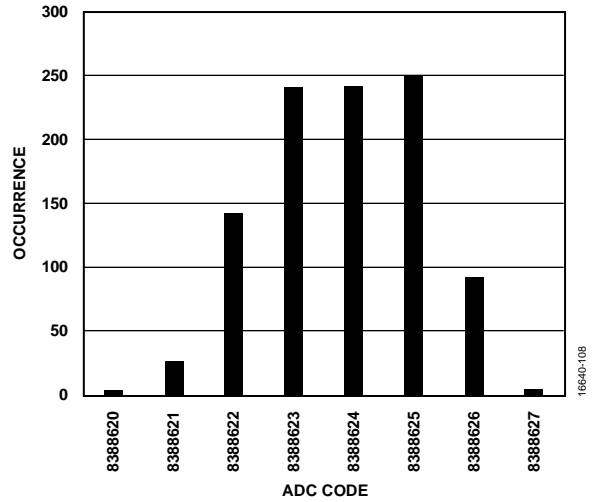

Figure 8. Histogram (Voltage Input, Output Data Rate = 1.25 SPS)

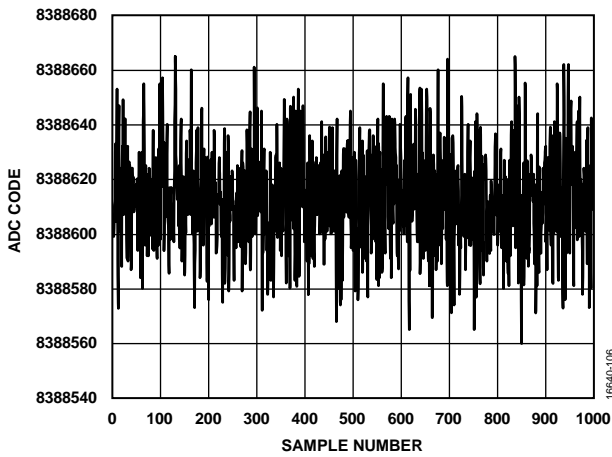

Figure 6. Noise (Voltage Input, Output Data Rate = 2.5 kSPS)

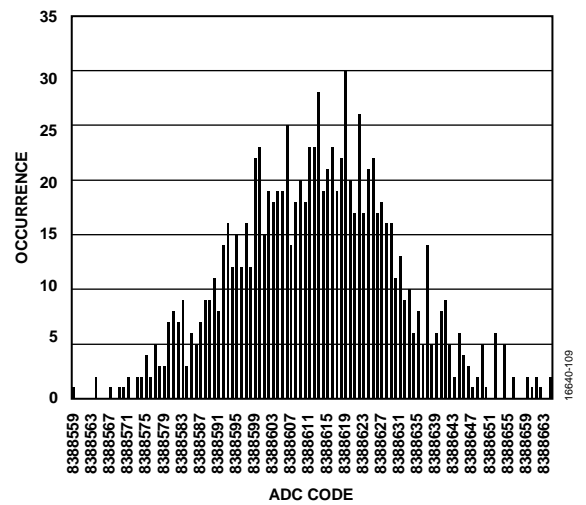

Figure 9. Histogram (Voltage Input, Output Data Rate = 2.5 kSPS)

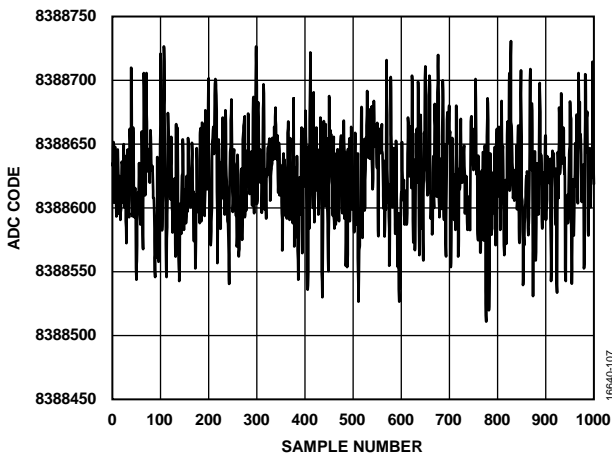

Figure 7. Noise (Voltage Input, Output Data Rate = 31.25 kSPS)

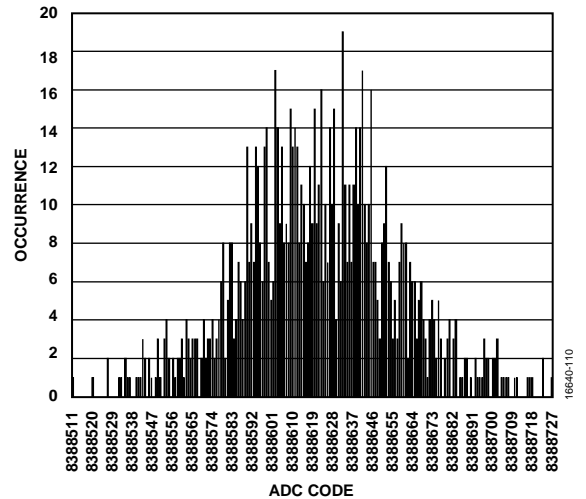

Figure 10. Histogram (Voltage Input, Output Data Rate = 31.25 kSPS)

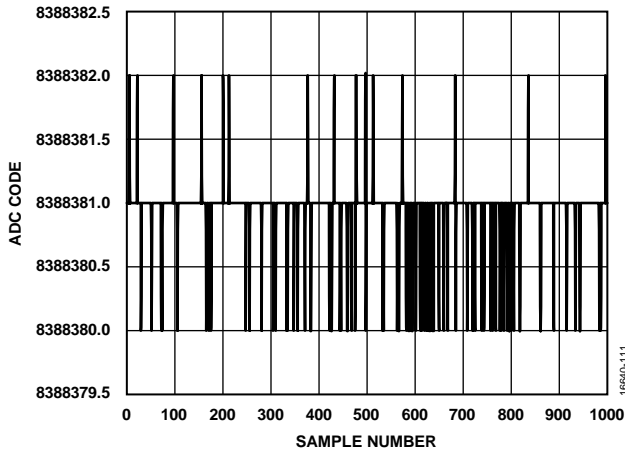

Figure 11. Noise (Current Input, Output Data Rate = 1.25 SPS)

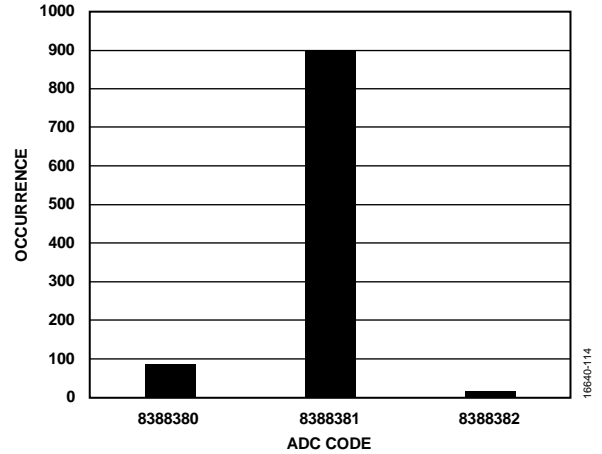

Figure 14. Histogram (Current Input, Output Data Rate = 1.25 SPS)

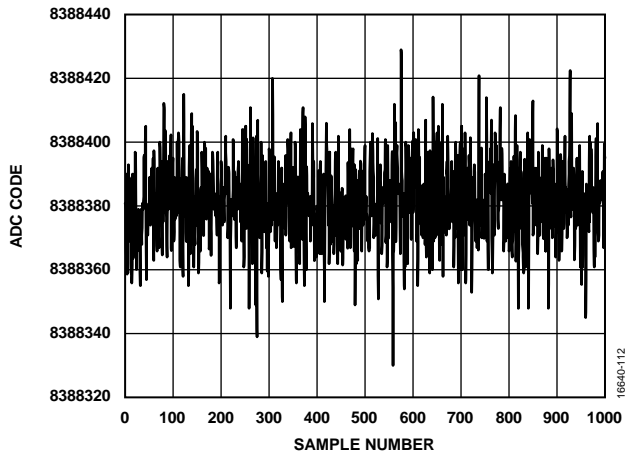

Figure 12. Noise (Current Input, Output Data Rate = 2.5 kSPS)

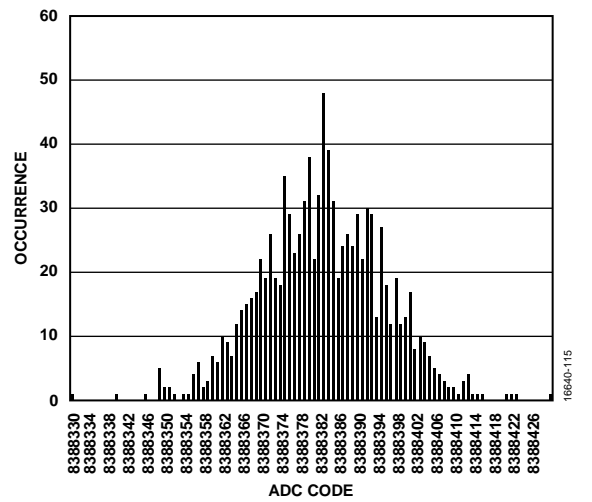

Figure 15. Histogram (Current Input, Output Data Rate = 31.25 SPS)

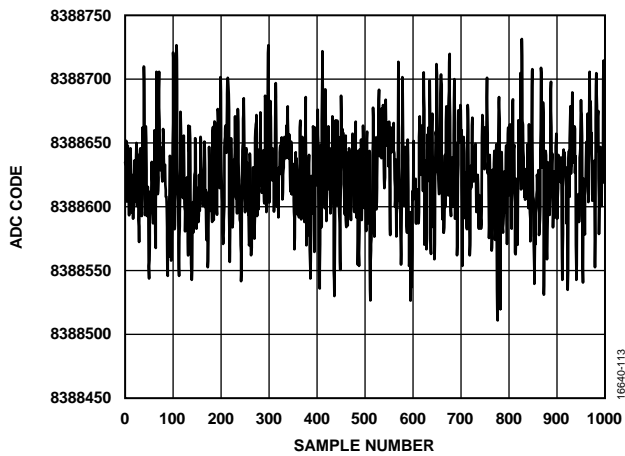

Figure 13. Noise (Current Input, Output Data Rate = 31.25 kSPS)

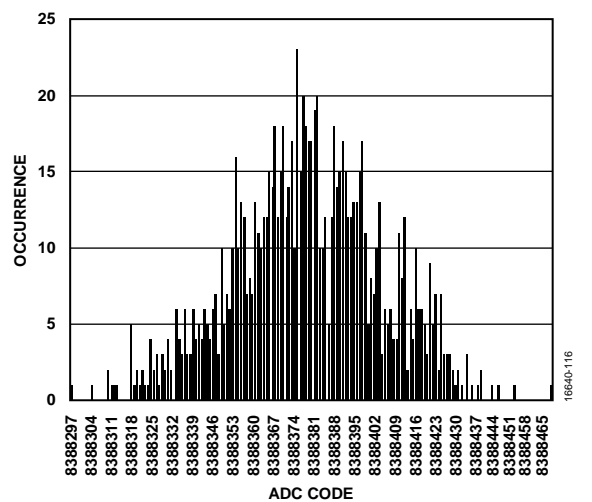

Figure 16. Histogram (Current Input, Output Data Rate = 31.25 kSPS)

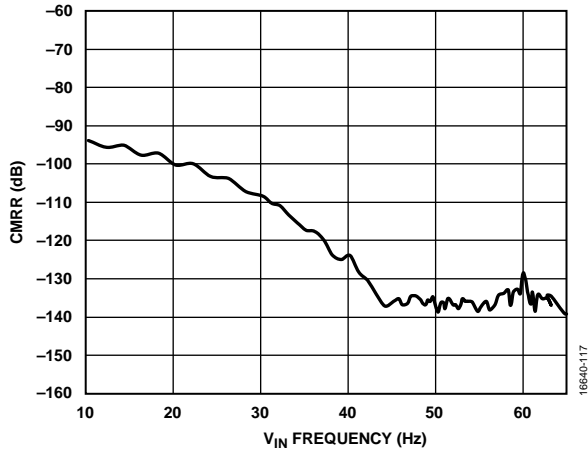

Figure 17. Common-Mode Rejection Ratio (CMRR) vs. V_{IN} Frequency ($V_{IN} = 0.1$ V, 10 Hz to 70 Hz, Output)

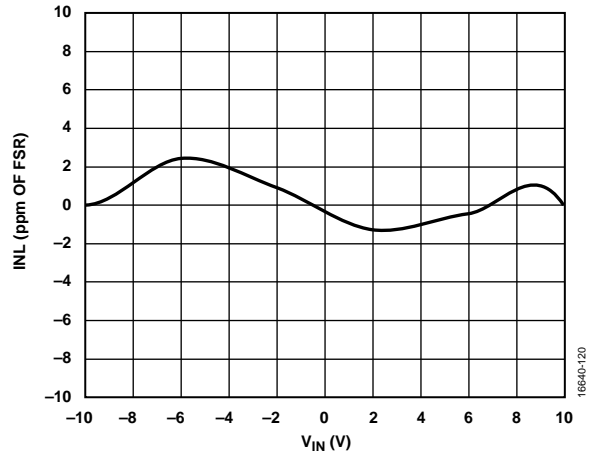

Figure 20. Integral Nonlinearity (INL) vs. Input Range (Voltage Input)

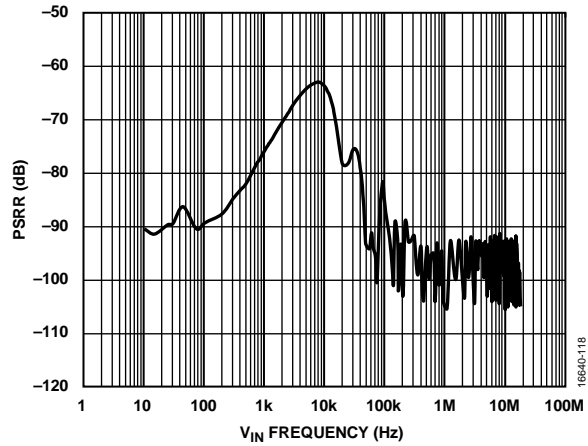

Figure 18. Power Supply Rejection Ratio (PSRR) vs. V_{IN} Frequency

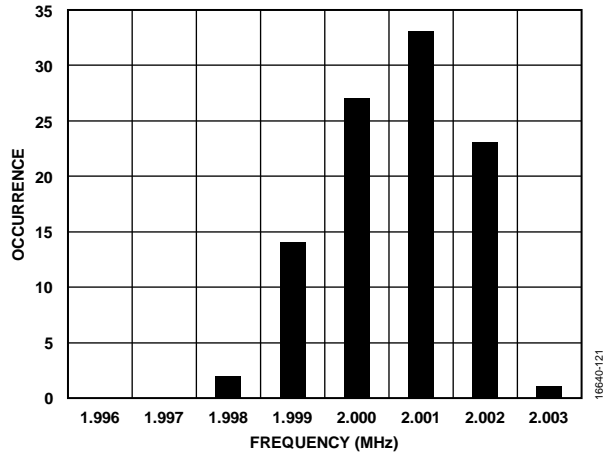

Figure 21. Internal Oscillator Frequency/Accuracy Distribution Histogram

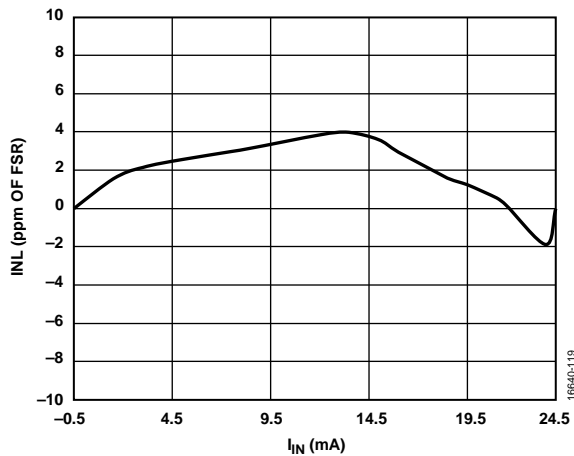

Figure 19. Integral Nonlinearity (INL) vs. Input (Current Input)

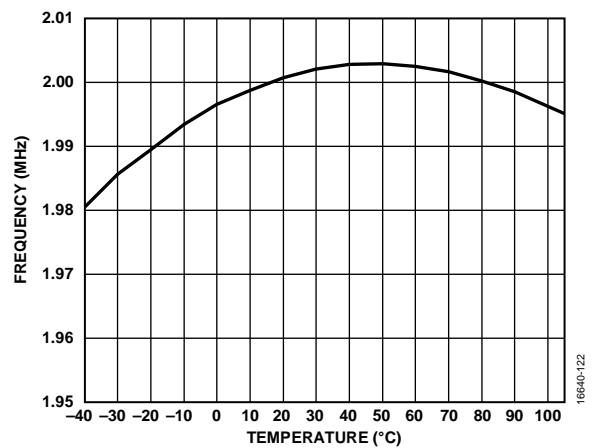

Figure 22. Internal Oscillator Frequency vs. Temperature

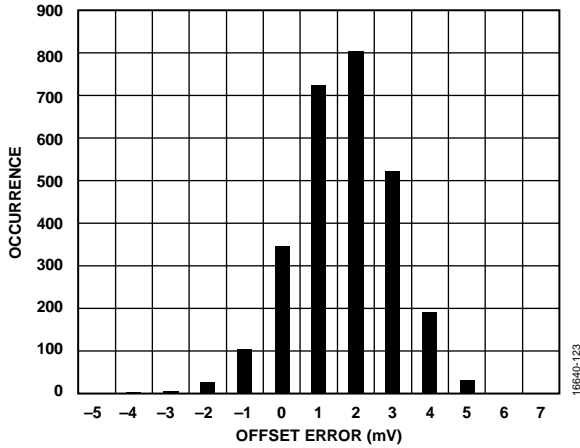

Figure 23. Offset Error Distribution Histogram (Voltage Input)

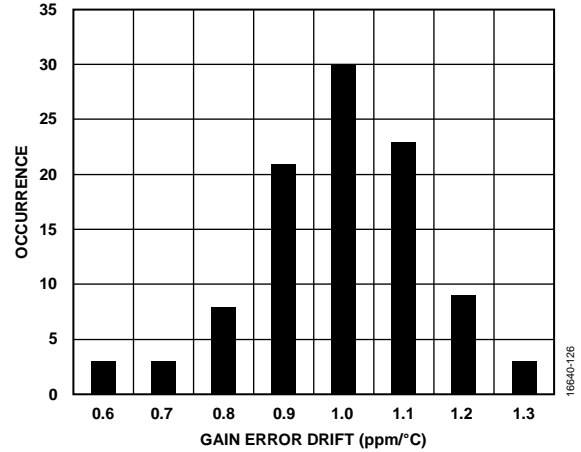

Figure 26. Gain Error Drift Distribution Histogram (Voltage Input)

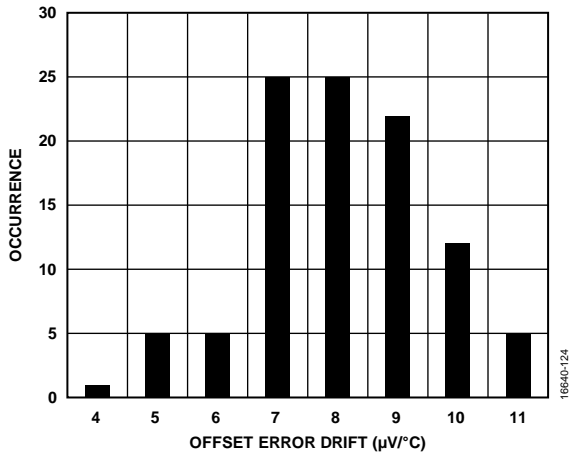

Figure 24. Offset Error Drift Distribution Histogram (Voltage Input)

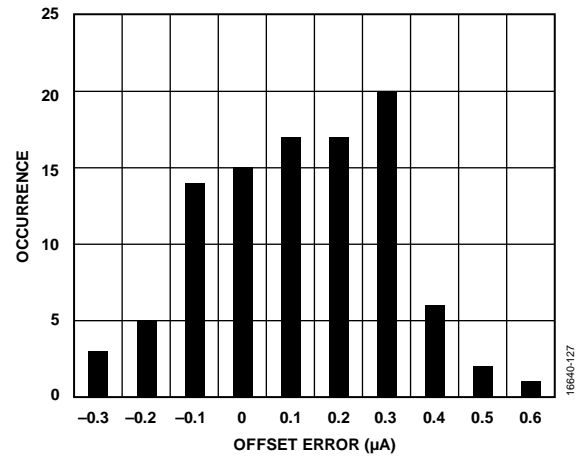

Figure 27. Offset Error Distribution Histogram (Current Input)

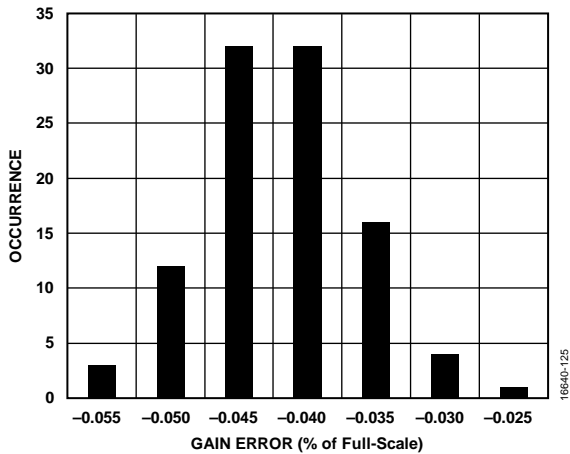

Figure 25. Gain Error Distribution Histogram (Voltage Input)

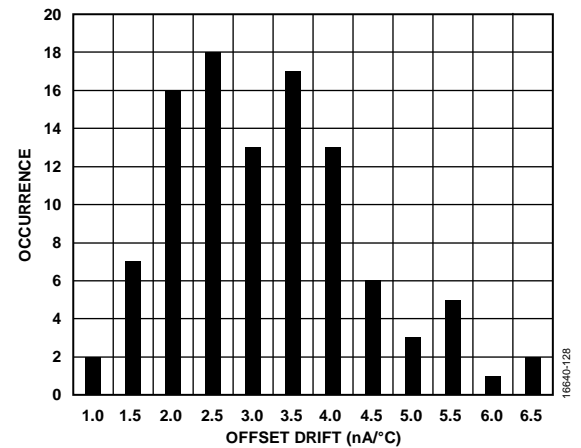

Figure 28. Offset Error Drift Distribution Histogram (Current Input)

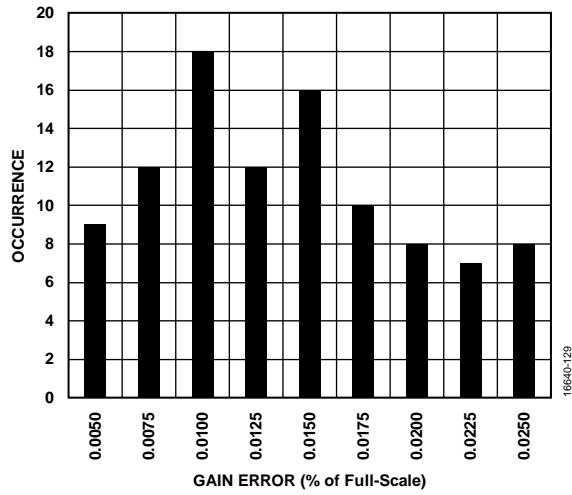

Figure 29. Gain Error Distribution Histogram (Current Input)

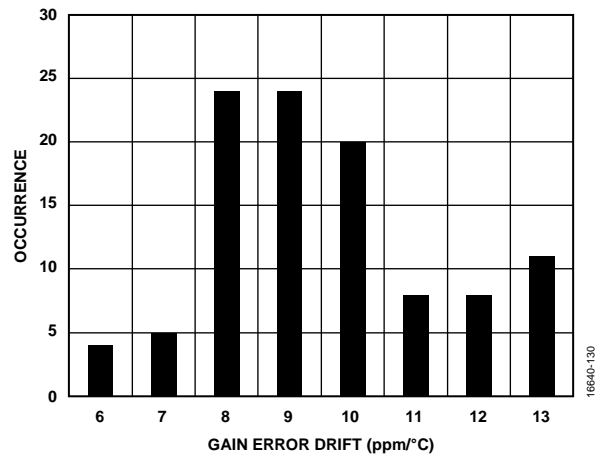

Figure 30. Gain Error Drift Distribution Histogram (Current Input)

NOISE PERFORMANCE AND RESOLUTION

Table 6 to Table 9 show the rms noise, peak-to-peak noise, effective resolution, and the noise free (peak-to-peak) resolution of the AD4111 for various ODRs. These values are typical and are measured with an external 2.5 V reference and with the ADC continuously converting on multiple channels. The values in Table 6 and Table 8 are generated for the ± 10 V

voltage input range, with a differential input voltage of 0 V. The values in Table 7 and Table 9 are generated for the 0 mA to 20 mA input range, with an input current of 0 mA. It is important to note that the peak-to-peak resolution is calculated based on the peak-to-peak noise. The peak-to-peak resolution represents the resolution for which there is no code flicker.

Table 6. ± 10 V Voltage Input RMS Noise Resolution vs. ODR Using a Sinc5 + Sinc1 Filter

Default Output Data Rate (SPS); SING_CYC = 0 and Single Channel Enabled	Output Data Rate (SPS per Channel); SING_CYC = 1 or Multiple Channels Enabled	Settling Time ¹	Notch Frequency (Hz)	Noise (μ V rms) ²	Effective Resolution (Bits)	Noise (μ V p-p)	Peak-to-Peak Resolution (Bits)
31,250	6211.18	161 μ s	31,250	106	17.5	750	14.7
15,625	5181.65	193 μ s	15,625	94	17.7	580	15.1
10,417	4444	225 μ s	10,417	82	17.9	512	15.3
5208	3115	321 μ s	5208	62	18.3	372	15.7
2597.4	2597.4	385 μ s	3906	47	18.7	312	16.0
1007	1007.1	993 μ s	1157	27	19.5	190	16.7
504	504	1.99 ms	539	21	19.9	140	17.1
381	381	2.63 ms	401	17	20.2	92	17.7
200.3	200.3	4.99 ms	206	13	20.6	62	18.3
100.2	100.2	9.99 ms	102	8	21.3	45	18.8
59.52	59.52	16.8 ms	59.98	7	21.4	33	19.2
49.68	49.68	20.13 ms	50	7	21.4	33	19.2
20.01	20.01	49.98 ms	20.06	4	22.3	22	19.8
16.63	16.63	60.13 ms	16.67	4	22.3	21	19.9
10	10	100 ms	10	3.7	22.4	18	20.1
5	5	200 ms	5	3.4	22.5	17	20.2
2.5	2.5	400 ms	2.5	2.4	23	12	20.7
1.25	1.25	800 ms	1.25	2.3	23.1	11	20.8

¹ The settling time is rounded to the nearest microsecond, which is reflected in the output data rate and channel switching rate. Channel switching rate = $1 \div$ settling time.

² Based on 1000 samples for data rates ≥ 381 SPS per channel, based on 100 samples for data rates ≤ 200.3 SPS per channel.

Table 7. 0 mA to 20 mA Current Input Noise and Resolution vs. Output Data Rate Using a Sinc5 + Sinc1 Filter

Default Output Data Rate (SPS); SING_CYC = 0 and Single Channel Enabled	Output Data Rate (SPS per Channel); SING_CYC = 1 or Multiple Channels Enabled	Settling Time ¹	Notch Frequency (Hz)	Noise (nA rms) ²	Effective Resolution (Bits)	Noise (nA p-p)	Peak-to-Peak Resolution (Bits)
31,250	6211.18	161 μ s	31,250	155	17.0	1100	14.2
15,625	5181.65	193 μ s	15,625	136	17.2	920	14.4
10,417	4444	225 μ s	10,417	113	17.4	720	14.8
5208	3115	321 μ s	5208	84	17.9	580	15.1
2597.4	2597.4	385 μ s	3906	75	18.0	480	15.3
1007	1007.1	993 μ s	1157	43	18.8	220	16.5
504	503.8	1.99 ms	539	29	19.4	150	17.0
381	381	2.63 ms	401	21	19.9	125	17.3
200.3	200.3	4.99 ms	206	18	20.1	95	17.7
100.2	100.2	9.99 ms	102	13	20.6	71	18.1
59.52	59.52	16.8 ms	59.98	10	20.9	48	18.7
49.68	49.68	20.13 ms	50	9	21.1	41	18.9
20.01	20.01	49.98 ms	20.06	6	21.7	30	19.3
16.63	16.63	60.13 ms	16.67	5.3	21.8	23	19.7
10	10	100 ms	10	4.6	22.1	18	20.1
5	5	200 ms	5	3	22.7	12	20.7
2.5	2.5	400 ms	2.5	2.8	22.8	12	20.7
1.25	1.25	800 ms	1.25	2.7	22.8	6	21.7

¹ The settling time is rounded to the nearest microsecond, which is reflected in the output data rate and channel switching rate. Channel switching rate = $1 \div$ settling time.

² Based on 1000 samples for data rates ≥ 381 SPS per channel, based on 100 samples for data rates ≤ 200.3 SPS per channel.

Table 8. ± 10 V Voltage Input RMS Noise Resolution vs. ODR Using a Sinc3 Filter

Default Output Data Rate (SPS); SING_CYC = 0 and Single Channel Enabled	Output Data Rate (SPS per Channel); SING_CYC = 1 or Multiple Channels Enabled	Settling Time ¹	Notch Frequency (Hz)	Noise ($\mu\text{V rms}$) ²	Effective Resolution (Bits)	Noise ($\mu\text{V p-p}$)	Peak-to-Peak Resolution (Bits)
31,250	10309.28	97 μs	31,250	1035	14.2	6037	11.7
15,625	5181.35	193 μs	15,625	158	16.9	954	14.4
10,417	3460.21	289 μs	10,417	77	18	536	15.2
5208	1733	577 μs	5208	50	18.6	334	15.9
2604.2	867.3	1.15 ms	2604.2	34	19.2	205	16.6
1008.1	335.9	2.98 ms	1008.1	22	19.8	137	17.2
504	167.98	5.95 ms	504	15	20.3	108	17.5
401	133.5	7.49 ms	401	13	20.5	82	17.9
200.3	66.67	14.99 ms	200.3	10	20.9	65	18.2
100.16	33.39	30.00 ms	100.2	7.3	21.4	39	18.9
59.98	19.99	50.02 ms	59.98	6.2	21.6	35	19.1
50	16.67	60 ms	50	5.3	21.8	36	19.1
20	6.67	149.95 ms	20	4.9	22	33	19.2
16.67	5.56	180.0 ms	16.67	4.2	22.1	29.8	19.35
10	3.33	300 ms	10	3.7	22.4	20.9	19.9
5	1.67	600 ms	5	3.5	22.4	17.8	20.1
2.5	0.83	1.2 sec	2.5	3	22.7	17.8	20.1
1.25	0.42	2.4 sec	1.25	2.9	22.7	14.9	20.4

¹ The settling time is rounded to the nearest microsecond, which is reflected in the output data rate and channel switching rate. Channel switching rate = $1 \div$ settling time.

² Based on 1000 samples for data rates ≥ 381 SPS per channel, based on 100 samples for data rates ≤ 200.3 SPS per channel.

Table 9. 0 mA to 20 mA Current Input Noise and Resolution vs. Output Data Rate Using a Sinc3 Filter

Default Output Data Rate (SPS); SING_CYC = 0 and Single Channel Enabled	Output Data Rate (SPS per Channel); SING_CYC = 1 or Multiple Channels Enabled	Settling Time ¹	Notch Frequency (Hz)	Noise (nA rms) ²	Effective Resolution (Bits)	Noise (nA p-p)	Peak-to-Peak Resolution (Bits)
31,250	10309.28	97 μs	31,250	2177	15.5	13315	12.9
15,625	5181.35	193 μs	15,625	309	18.3	1830	15.8
10,417	3460.21	289 μs	10,417	121	19.7	781	17
5208	1733	577 μs	5208	72	20.4	452	17.8
2604.2	867.3	1.15 ms	2604.2	49	20.9	339	18.2
1008.1	335.9	2.98 ms	1008.1	30	21.6	214	18.8
504	167.98	5.95 ms	504	22	22.1	149	19.4
401	133.5	7.49 ms	401	19	2.3	125	19.6
200.3	66.67	14.99 ms	200.3	14	22.8	77	20.3
100.16	33.39	30.00 ms	100.2	10	23.2	71	20.4
59.98	19.99	50.02 ms	59.98	7.6	23.6	53	20.8
50	16.67	60 ms	50	7.2	23.7	41	21.2
20	6.67	149.95 ms	20	4.8	24	29.8	21.7
16.67	5.56	180.0 ms	16.67	4.4	24	29.8	21.7
10	3.33	300 ms	10	3.8	24	23.8	22
5	1.67	600 ms	5	3.1	24	17.9	22.4
2.5	0.83	1.2 sec	2.5	2.6	24	11.9	23
1.25	0.42	2.4 sec	1.25	2.4	24	11.9	23

¹ The settling time is rounded to the nearest microsecond, which is reflected in the output data rate and channel switching rate. Channel switching rate = $1 \div$ settling time.

² Based on 1000 samples for data rates ≥ 381 SPS per channel, based on 100 samples for data rates ≤ 200.3 SPS per channel.

THEORY OF OPERATION

The AD4111 offers the user a fast settling, high resolution, multiplexed ADC with high levels of configurability, including the following features:

- Four fully differential or eight single-ended voltage inputs.
- High impedance voltage divider with integrated precision matched resistors
- Four current inputs with integrated current sense resistors.
- Embedded proprietary *iPassives™* technology within a very small device footprint.
- Per channel configurability—up to eight different setups can be defined. A separate setup can be mapped to each of the channels. Each setup allows the user to configure whether the buffers are enabled or disabled, gain and offset correction, filter type, ODR, and reference source selection.

The AD4111 includes a precision, 2.5 V, low drift (5 ppm/°C), band gap internal reference. This reference can be selected for use in ADC conversions, reducing the external component count. When enabled, the internal reference is output to the REFOUT pin. It can be used as a low noise biasing voltage for the external circuitry and must be connected to a 0.1 μF decoupling capacitor.

The AD4111 includes two separate linear regulator blocks for both the analog and digital circuitry. The analog LDO regulator regulates the AVDD supply to 1.8 V.

The linear regulator for the digital IOVDD supply performs a similar function, regulating the input voltage applied at the IOVDD pin to 1.8 V. The serial interface signals always operate from the IOVDD supply seen at the pin; meaning that, if 3.3 V is applied to the IOVDD pin, the interface logic inputs and outputs operate at this level.

The AD4111 is designed for a multitude of factory automation and process control applications, such as programmable logic controller (PLC) and distributed control system (DCS) modules. The AD4111 reduces overall system cost and design burden while maintaining a very high level of accuracy. The AD4111 offers the following system benefits:

- A single 5 V or 3.3 V power supply.
- Guaranteed minimum 1 M Ω input impedance.
- Overrange voltage greater than ± 10 V.
- Integrated sense resistors for direct current input measurement.
- Reduced calibration costs.
- Voltage input open wire detection.

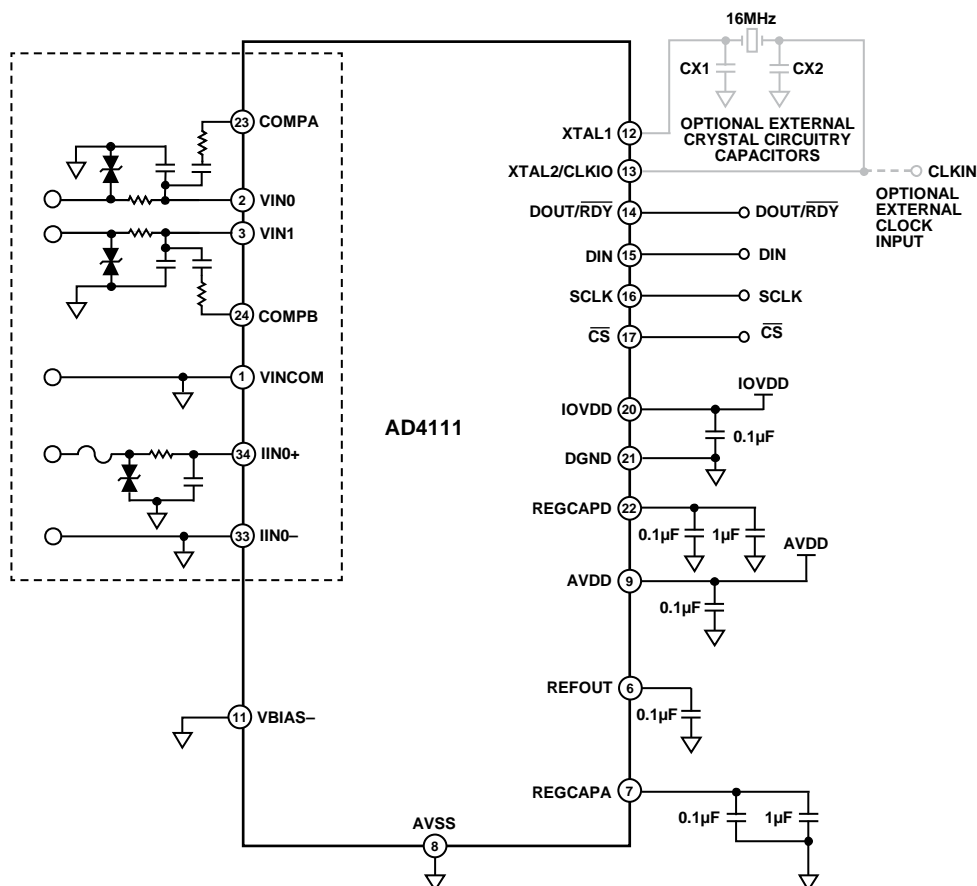

Figure 31. Typical Connection Diagram

POWER SUPPLIES

The AD4111 has two independent power supply pins: AVDD, and IOVDD. The AD4111 has no specific requirements for a power supply sequence. However, when all power supplies are stable, a device reset is required. See the AD4111 Reset section for details on how to reset the device.

AVDD powers the internal 1.8 V analog LDO regulator, which powers the ADC core. AVDD also powers the crosspoint multiplexer and integrated input buffers. AVDD is referenced to AVSS, and AVDD – AVSS = 3.3 V or 5 V. AVDD and AVSS can be a single 3.3 V or 5 V supply, or a ±1.65 V or ±2.5 V split supply. When using split supplies, consider the absolute maximum ratings (see the Absolute Maximum Ratings section).

IOVDD powers the internal 1.8 V digital LDO regulator. This regulator powers the digital logic of the ADC. IOVDD sets the voltage levels for the serial peripheral interface (SPI) of the ADC. IOVDD is referenced to DGND, and IOVDD to DGND can vary from 2 V (minimum) to 5.5 V (maximum).

Single-Supply Operation (AVSS = DGND)

When the AD4111 is powered from a single supply connected to AVDD, the supply can be either 3.3 V or 5 V. In this configuration, AVSS and DGND can be shorted together on one single ground plane.

IOVDD can range from 2 V to 5.5 V in this unipolar input configuration.

DIGITAL COMMUNICATION

The AD4111 has a 3-wire or 4-wire SPI interface that is compatible with QSPI™, MICROWIRE®, and DSPs. The interface operates in SPI Mode 3 and can be operated with \overline{CS} tied low. In SPI Mode 3, SCLK idles high, the falling edge of SCLK is the drive edge, and the rising edge of SCLK is the sample edge. Data is clocked out on the falling/drive edge and data is clocked in on the rising/sample edge.

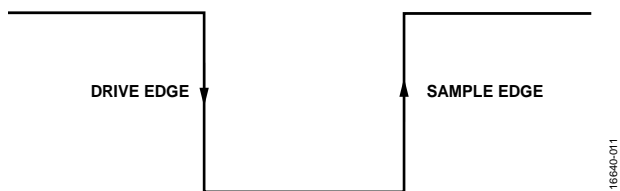

Figure 32. SPI Mode 3 SCLK Edges

Accessing the ADC Register Map

The communications register controls access to the full register map of the ADC. This register is an 8-bit write only register. On power-up or after a reset, the digital interface defaults to a state where it is expecting a write to the communications register. Therefore, all communication begins by writing to the communications register.

The data written to the communications register determines which register is being accessed and if the next operation is a read or write. The RA bits (Bits[5:0] in Register 0x00)

determine the specific register to which the read or write operation applies.

When the read or write operation to the selected register is complete, the interface returns to its default state, where it expects a write operation to the communications register.

In situations where interface synchronization is lost, a write operation of at least 64 serial clock cycles with DIN high returns the ADC to its default state by resetting the entire device, including the register contents. Alternatively, if \overline{CS} is being used with the digital interface, returning \overline{CS} high resets the digital interface to its default state and aborts any current operation.

Figure 33 and Figure 34 show writing to and reading from a register by first writing the 8-bit command to the communications register followed by the data for the addressed register.

Reading the ID register is the recommended method for verifying correct communication with the device. The ID register is a read only register and contains the value 0x30DX for the AD4111. The communication register and ID register details are described in Table 10 and Table 11.

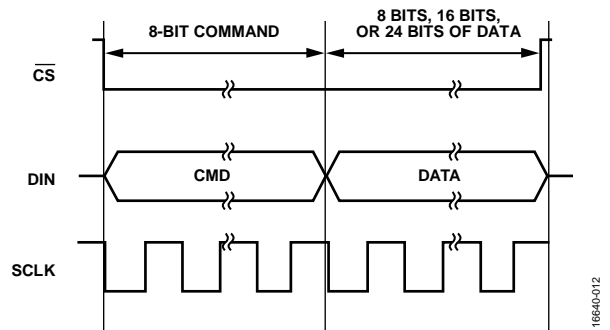

Figure 33. Writing to a Register (8-Bit Command with Register Address Followed by Data of 8 Bits, 16 Bits, or 24 Bits; Data Length Is Dependent on the Register Selected)

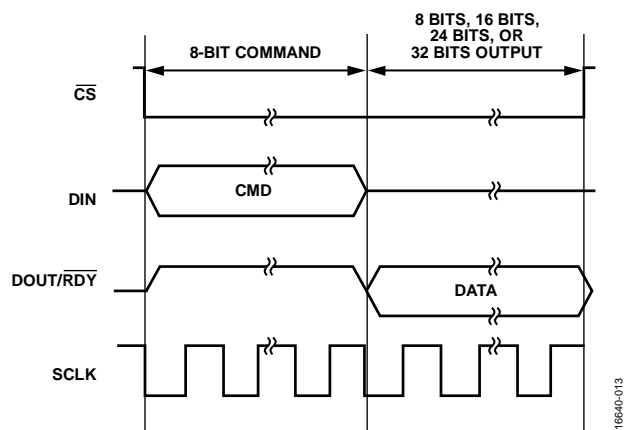

Figure 34. Reading from a Register (8-Bit Command with Register Address Followed by Data of 8 Bits, 16 Bits, 24, or 32 Bits; Data Length on DOUT Is Dependent on the Register Selected)

AD4111 RESET

After a power-up cycle and when the power supplies are stable, a device reset is required. In situations where interface synchronization is lost, a device reset is also required. A write operation of at least 64 serial clock cycles with DIN high returns the ADC to

the default state by resetting the entire device, including the register contents. Alternatively, if \overline{CS} is being used with the digital interface, returning \overline{CS} high sets the digital interface to the default state and halts any serial interface operation.

Table 10. Communications Register Bit Map

Reg.	Name	Bits	Bit 7	Bit 6	Bit 5	Bit 4	Bit 3	Bit 2	Bit 1	Bit 0	Reset	RW
0x00	COMMS	[7:0]	\overline{WEN}	R/ \overline{W}	RA						0x00	W

Table 11. ID Register Bit Map

Reg.	Name	Bits	Bit 7	Bit 6	Bit 5	Bit 4	Bit 3	Bit 2	Bit 1	Bit 0	Reset	RW
0x07	ID	[15:8]	ID[15:8]								0x30DX ¹	R
		[7:0]	ID[7:0]									

¹ X means don't care.

CONFIGURATION OVERVIEW

After power-on or reset, the AD4111 default configuration is as follows:

- Channel configuration: Channel 0 is enabled, the VIN0 and VIN1 pair is selected as the input. Setup 0 is selected.
- Setup configuration: the analog input buffers are disabled and the reference input buffers are also disabled. The REF± pins are selected as the reference source. Note that for this setup, the default channel does not operate correctly because the input buffers need to be enabled for a VIN input.
- Filter configuration: the sinc5 + sinc1 filter is selected and the maximum output data rate of 31.25 kSPS is selected.
- ADC mode: continuous conversion mode and the internal oscillator are enabled. The internal reference is disabled.
- Interface mode: CRC and the data and status output are disabled.
- GPIO configuration: open wire detection is disabled.

Note that only a few of the register setting options are shown. This list is only an example. For full register information, see the Register Details section.

Figure 35 shows an overview of the suggested flow for changing the ADC configuration, divided into the following three blocks:

- Channel configuration (see Box A in Figure 35)
- Setup configuration (see Box B in Figure 35)
- ADC mode and interface mode configuration (see Box C in Figure 35)

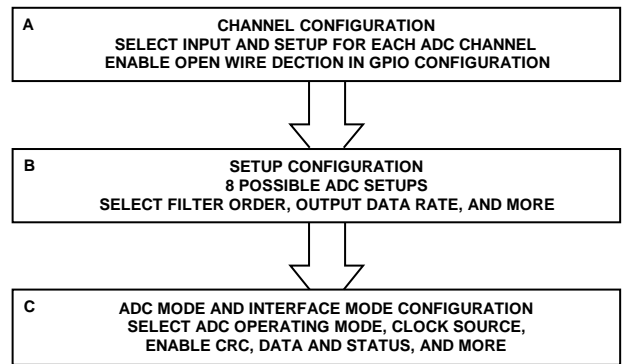

Figure 35. Suggested ADC Configuration Flow

Table 12. Channel Register 0

Reg.	Name	Bits	Bit 7	Bit 6	Bit 5	Bit 4	Bit 3	Bit 2	Bit 1	Bit 0	Reset	RW
0x10	CH0	[15:8]	CH_EN0	SETUP_SEL0			Reserved		INPUT[9:8]		0x8001	RW
		[7:0]	INPUT[7:0]									

Channel Configuration

The AD4111 has 16 independent channels and 8 independent setups. When open wire detection is not enabled, the user can select any of the input pairs on any channel, as well as any of the eight setups for any channel, giving the user full flexibility in the channel configuration. This flexibility also allows per channel configuration when using differential inputs and single-ended inputs because each channel can have its own dedicated setup. When open wire detection is enabled, the input selection per channel must follow the guidelines documented in the Open Wire Detection section. Open wire detection is enabled in the GPIO configuration register.

Channel Registers

The channel registers select which of the voltage or current inputs is used for that channel. This register also contains a channel enable/disable bit and the setup selection bits, which are used to select which of the eight available setups to use for this channel.

When the AD4111 is operating with more than one channel enabled, the channel sequencer cycles through the enabled channels in sequential order, from Channel 0 to Channel 15. If a channel is disabled, it is skipped by the sequencer. Details of the channel register for Channel 0 are shown in Table 12.

ADC Setups

The AD4111 has eight independent setups. Each setup consists of the following four registers:

- Setup configuration register
- Filter configuration register
- Gain register
- Offset register

For example, Setup 0 consists of Setup Configuration Register 0, Filter Configuration Register 0, Gain Register 0, and Offset Register 0. Figure 36 shows the grouping of these registers. The setup is selectable from the channel registers (see the Channel Configuration section), which allows each channel to be assigned to one of eight separate setups. Table 13 through Table 16 show the four registers that are associated with Setup 0. This structure is repeated for Setup 1 to Setup 7.

Setup Configuration Registers

The setup configuration registers allow the user to select the output coding of the ADC by selecting between bipolar mode and unipolar mode. The user can select the reference source using these registers. Three options are available: a reference connected between the REF+ and REF– pins, the internal reference, or using AVDD – AVSS. The input and reference buffers can also be enabled or disabled using these registers.

Filter Configuration Registers

The filter configuration registers select which digital filter is used at the output of the ADC modulator. The order of the filter and the output data rate are selected by setting the bits in these registers. For more information, see the Digital Filter section.

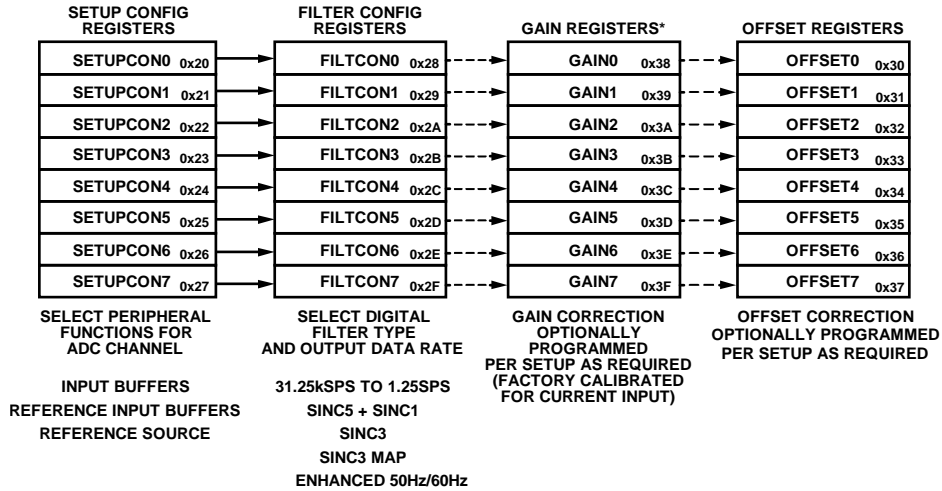

Figure 36. ADC Setup Register Grouping

Table 13. Setup Configuration Register 0

Reg.	Name	Bits	Bit 7	Bit 6	Bit 5	Bit 4	Bit 3	Bit 2	Bit 1	Bit 0	Reset	RW
0x20	SETUPCON0	[15:8]	Reserved			BI_UNIPOLAR0	REFBUF0+	REFBUF0–	INBUF0		0x1000	RW
		[7:0]	Reserved	Reserved	REF_SELO		Reserved					

Table 14. Filter Configuration Register 0

Reg.	Name	Bits	Bit 7	Bit 6	Bit 5	Bit 4	Bit 3	Bit 2	Bit 1	Bit 0	Reset	RW
0x28	FILTCON0	[15:8]	SINC3_MAP0	Reserved			ENHFILTENO	ENHFILTO			0x0500	RW
		[7:0]	Reserved	ORDER0		ODR0						

Table 15. Gain Register 0

Reg.	Name	Bits	Bits[23:0]	Reset	RW
0x38	GAIN0	[23:0]	GAIN0[23:0]	0x5XXXX0	RW

Table 16. Offset Register 0

Reg.	Name	Bits	Bits[23:0]	Reset	RW
0x30	OFFSET0	[23:0]	OFFSET0[23:0]	0x800000	RW

Gain Registers

The gain registers are 24-bit registers that hold the gain calibration coefficient for the ADC. The gain registers are read/write registers. At power-on, these registers are configured for current inputs with factory calibrated coefficients. Therefore, every device has different default coefficients. When enabling a voltage input on a channel register (see the Channel Registers section), the user must also update the gain register for the corresponding setup. For more information, see the Adjusting Voltage Input Gain section.

Offset Registers

The offset registers hold the offset calibration coefficient for the ADC. The power-on reset value of the offset registers is 0x800000. The offset registers are 24-bit read and write registers.

ADC Mode and Interface Mode Configuration

The ADC mode register and the interface mode register configure the core peripherals for use by the AD4111 and the mode for the digital interface.

ADC Mode Register

The ADC mode register primarily sets the conversion mode of the ADC to either continuous or single conversion. The user can also select the standby and power-down modes, as well as any of the calibration modes. In addition, this register contains the clock source select bits and internal reference enable bit. The reference select bits are contained in the setup configuration registers (see the ADC Setups section for more information). The details of this register are shown in Table 17.

Interface Mode Register

The interface mode register configures the digital interface operation. This register allows the user to control data-word length, CRC enable, data plus status read, and continuous read mode. The details of this register are shown in Table 18. For more information, see the Digital Interface section.

Table 17. ADC Mode Register

Reg.	Name	Bits	Bit 7	Bit 6	Bit 5	Bit 4	Bit 3	Bit 2	Bit 1	Bit 0	Reset	RW
0x01	ADCMODE	[15:8]	REF_EN	Reserved	SING_CYC	Reserved		Delay			0x2000	RW
		[7:0]	Reserved	Mode			CLOCKSEL		Reserved			

Table 18. Interface Mode Register

Reg.	Name	Bits	Bit 7	Bit 6	Bit 5	Bit 4	Bit 3	Bit 2	Bit 1	Bit 0	Reset	RW
0x02	IFMODE	[15:8]	Reserved			ALT_SYNC	IOSTRENGTH	Reserved		DOUT_RESET	0x0000	RW
		[7:0]	CONTREAD	DATA_STAT	REG_CHECK	Reserved	CRC_EN		Reserved	WL16		

CIRCUIT DESCRIPTION

MULTIPLEXER

There are nine voltage pins and eight current inputs: VIN0– to VIN7, VINCOM, IIN0+ to IIN3+, and IIN0– to IIN3–. Each of these pins connects to the internal multiplexer. The multiplexer enables these inputs to be configured as input pairs (see the Voltage Inputs section and the Current Inputs section for more information on how to set up these inputs). The AD4111 can have up to 16 active channels. When more than one channel is enabled, the channels are automatically sequenced in order from the lowest enabled channel number to the highest enabled channel number. The output of the multiplexer is connected to the input of the integrated true rail-to-rail buffers. These buffers can be bypassed and the multiplexer output can be directly connected to the switched capacitor input of the ADC.

The simplified input circuits are shown in Figure 37 and Figure 38.

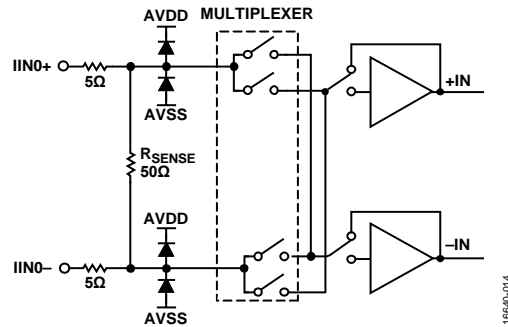

Figure 37. Simplified Current Input Circuit

16640-014

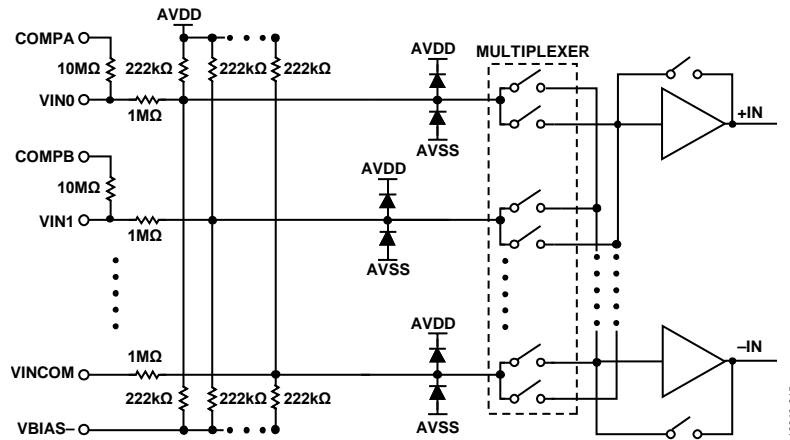

Figure 38. Simplified Voltage Input Circuit

16640-015

CURRENT INPUTS

There are four current input pins (IIN0+ to IIN3+) and four current return pins (IIN0– to IIN3–). Connect these pins in numbered pairs (for example, IIN0+ and IIN0–).

Disable the input buffers for the current inputs.

To achieve specified accuracy, the current channels are factory calibrated. This calibration value is stored in on-chip nonvolatile memory and is copied to all gain registers after a power-up or reset.

VOLTAGE INPUTS

The AD41111 can be set up to have eight single-ended inputs or four fully differential inputs. The voltage divider on the analog front end has a division ratio of 10 and consists of precision matched resistors that enable an input range of ± 20 V from a single 5 V power supply.

Enable the input buffers in the setup register for voltage input channels.

Fully Differential Inputs

Due to the matching resistors on the analog front end, the differential inputs must be paired together in the following pairs: VIN0 and VIN1, VIN2 and VIN3, VIN4 and VIN5, and VIN6 and VIN7. If any two voltage inputs are paired in a configuration other than what is described in this data sheet, the accuracy of the device cannot be guaranteed.

Single-Ended Inputs

The user can also choose to measure up to eight different single-ended voltage inputs. In this case, each of the voltage inputs must be paired with VINCOM. Connect VINCOM externally to AVSS.

Adjusting Voltage Input Gain

After a power-up or reset, all gain registers are loaded with factory calibration coefficients for current inputs. When using a voltage input, the corresponding gain register must be modified after powering up or resetting the device. Perform this modification by running an internal full-scale calibration (see the Calibration section for more information). Alternatively, the gain register can be overwritten with a nominal value of 0x55567C. However, a calibration is recommended because the ideal value varies from device to device.

Open Wire Detection

Open wire detection is a system level diagnostic that detects when an external sensor or source signal is disconnected from the system input. The AD4111 incorporates a unique feature that enables open wire detection on ± 10 V voltage inputs while operating on a 5 V or 3.3 V single power supply, which in existing designs requires a supply greater than ± 10 V. Open wire detection must be supported in user software. This section describes how to set up the AD4111 for open wire detection together with the associated calculations required.

Open wire detection is enabled by setting Bit 12 (OW_EN) and Bit 13 (OP_EN0_1) in the GPIO configuration register to 1 (see Table 30). Bit 6 (DATA_STAT) in the interface mode register, must also be set (see Table 27).

Voltage inputs must be assigned two channels per measurement when using open wire detection. Voltage inputs must also be assigned to specific channel pairs to ensure that open wire detection measurements work correctly. For single-ended input, open wire detection measurements, the channel pairings that must be used are as follows:

- Channel 15 and Channel 0
- Channel 1 and Channel 2
- Channel 3 and Channel 4
- Channel 5 and Channel 6
- Channel 7 and Channel 8
- Channel 9 and Channel 10
- Channel 11 and Channel 12
- Channel 13 and Channel 14

For differential input, open wire detection measurements, the channel pairings that must be used are as follows:

- Channel 1 and Channel 2
- Channel 5 and Channel 6
- Channel 9 and Channel 10
- Channel 13 and Channel 14

Additionally, for differential inputs, the inputs must be set up in the following differential pairs to ensure correct operation:

- VIN0 and VIN1
- VIN2 and VIN3
- VIN4 and VIN5
- VIN6 and VIN7

See Table 30 for more information on the channel registers.

After the AD4111 is configured correctly, the output data must be processed in user software to implement open wire detection. An open wire on an input is detected by comparing the absolute difference between the two channels associated with an input to a threshold. The suggested threshold is 300 mV input referred. This threshold is approximately 100,000 (0x0186A0) in decimal output code from the ADC when operating in bipolar configuration with a 2.5 V voltage reference and AVDD = 5 V. This threshold is approximately 200,000 (0x030D40) codes when operating in unipolar configuration. See the Data Output Coding section for more information on converting ADC output codes to volts. If the difference is greater than this threshold, an open wire must be flagged by the user software. Open wire detection operation is shown in the Example 1—Open Wire Detection (Single-Ended Input) section and the Example 2—Open Wire Detection (Differential Input) section.

Note that the following registers and settings are used in the examples shown in the Example 1—Open Wire Detection (Single-Ended Input) section and the Example 2—Open Wire Detection (Differential Input) section:

- IFMODE = 0x0040 enables data and status.
- GPIOCON = 0x3800 enables open wire detection.
- SETUPCON0 = 0x1300 enables input buffers and the external reference (2.5 V), and selects bipolar mode.
- Set GAIN0 as described in the Adjusting Voltage Input Gain section.
- All other registers are set to default values.

Example 1—Open Wire Detection (Single-Ended Input)

In this example,

- Channel 0 and Channel 15 = 0x8010 enables the single-ended input (VIN0, VINCOM) and Setup 0.
- The VIN0 and VINCOM pins are left floating. Nothing is connected to the pins.
- Channel 0 = 9,129,327 (2.2075 V).
- Channel 15 = 9,360,856 (2.8975 V).
- $|9,129,327 - 9,360,856| = 231,529$ (690 mV) > 100,000 (300 mV).
- Open wire is flagged.
- A 1 V input is connected to the VIN0 and VINCOM input pins.
- Channel 0 = 8,725,210 (1.00315 V).
- Channel 15 = 8,725,200 (1.00312 V).
- $|8,725,210 - 8,725,200| = 10$ (0.03 mV) < 100,000 (300 mV).
- Open wire is not flagged.

Example 2—Open Wire Detection (Differential Input)

In this example,

- Channel 1 and Channel 2 = 0x8001 enables the differential input (VIN0, VIN1) and Setup 0.
- Channel 0 cannot be used for the differential input. Disable Channel 0 by setting it to 0x0000.
- The VIN0 and VIN1 pins are left floating. Nothing is connected to the pins.
- Channel 1 = 8,619,210 (687 mV).
- Channel 2 = 8,157,971 (–687 mV).
- $|8,619,210 - 8,157,971| = 461,239$ (1.374 V) > 100,000 (300 mV).
- Open wire is flagged.
- A 1 V differential input is connected the VIN0 and VIN1 input pins.
- Channel 1 = 8,724,611 (1.0014 V).
- Channel 2 = 8,724,577 (1.0013 V).
- $|8,724,611 - 8,724,577| = 34$ (0.1 mV) < 100,000 (300 mV).
- Open wire is not flagged.

Open Wire Detection Compensation Pins

For the correct function of open wire detection, connect a capacitor and resistor in series between each compensation and voltage input pin. The recommended values are a 1 kΩ resistor and a 680 pF capacitor. There are two compensation pins, COMPA and COMPB. COMPA must be connected through the resistor and capacitor to VIN0, VIN2, VIN4, and VIN6. COMPB must be connected to VIN1, VIN3, VIN5, and VIN7 (see Table 5 and Figure 31).

DATA OUTPUT CODING

When the ADC is configured for unipolar operation, the output code is natural (straight) binary with a zero differential input voltage resulting in a code of 00 ... 00, a midscale voltage resulting in a code of 100 ... 000, and a full-scale input voltage resulting in a code of 111 ... 111. The output code for any input voltage is represented as

$$Code = (2^N \times V_{IN} \times 0.1) / V_{REF}$$

The output code for any input current is represented as

$$Code = (2^N \times I_{IN} \times 50 \Omega) / V_{REF}$$

When the ADC is configured for bipolar operation, the output code is offset binary with a negative full-scale voltage resulting in a code of 000 ... 000, a zero differential input voltage resulting in a code of 100 ... 000, and a positive full-scale input voltage resulting in a code of 111 ... 111. The output code for any analog input voltage can be represented as

$$Code = 2^{N-1} \times ((V_{IN} \times 0.1 / V_{REF}) + 1)$$

The output code for any input current is represented as

$$Code = 2^{N-1} \times ((I_{IN} \times 50 \Omega / V_{REF}) + 1)$$

where:

$N = 24$.

V_{IN} is the input voltage.

I_{IN} is the input current.

V_{REF} is the reference voltage.

AD4111 REFERENCE

The AD4111 offers the user the option of either supplying an external reference to the REF+ and REF- pins of the device, using AVDD – AVSS, or by allowing the use of the internal 2.5 V, low noise, low drift reference. Select the reference source to be used by the analog input by setting the REF_SELx bits,

Bits[5:4], in the setup configuration registers appropriately. The structure of the Setup Configuration 0 register is shown in Table 19. By default, the AD4111 uses an external reference on power-up.

Internal Reference

The AD4111 includes a low noise, low drift voltage reference. The internal reference has a 2.5 V output. The internal reference is output on the REFOUT pin after the REF_EN bit in the ADC mode register is set and is decoupled to AVSS with a 0.1 μF capacitor. The AD4111 internal reference is disabled by default on power-up.

External Reference

The AD4111 has a fully differential reference input applied through the REF+ and REF- pins. Standard low noise, low drift voltage references, such as the ADR4525, are recommended for use. Apply the external reference to the AD4111 reference pins as shown in Figure 39. Decouple the output of any external reference to AVSS. As shown in Figure 39, the ADR4525 output is decoupled with a 0.1 μF capacitor at the output for stability purposes. The output is then connected to a 4.7 μF capacitor, which acts as a reservoir for any dynamic charge required by the ADC, and is followed by a 0.1 μF decoupling capacitor at the REF+ input. This capacitor is placed as close as possible to the REF+ and REF- pins.

The REF- pin is connected directly to the AVSS potential. When an external reference is used instead of the internal reference to supply the AD4111, attention must be paid to the output of the REFOUT pin. The internal reference is controlled by the REF_EN bit (Bit 15) in the ADC mode register, which is shown in Table 20. If the internal reference is not being used elsewhere in the application, ensure that the REF_EN bit is disabled.

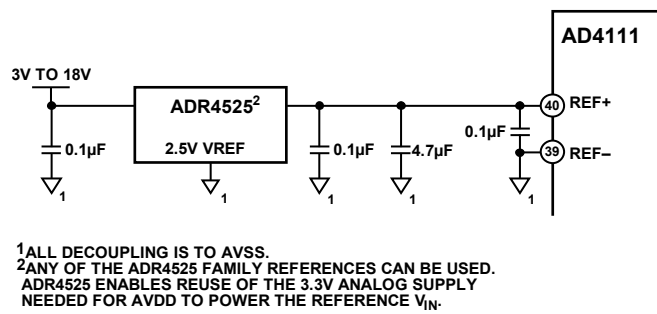

Figure 39. ADR4525 Connected to AD4111 REF± Pins

Table 19. Setup Configuration 0 Register

Reg.	Name	Bits	Bit 7	Bit 6	Bit 5	Bit 4	Bit 3	Bit 2	Bit 1	Bit 0	Reset	RW
0x20	SETUPCON0	[15:8]	Reserved			BI_UNIPOLAR0	REFBUFO+	REFBUFO-	INBUFO		0x1000	RW
		[7:0]	Reserved	Reserved	REF_SEL0		Reserved					

Table 20. ADC Mode Register

Reg.	Name	Bits	Bit 7	Bit 6	Bit 5	Bit 4	Bit 3	Bit 2	Bit 1	Bit 0	Reset	RW
0x01	ADCMODE	[15:8]	REF_EN	Reserved	SING_CYC	Reserved		Delay			0x2000	RW
		[7:0]	Reserved	Mode			CLOCKSEL		Reserved			

BUFFERED REFERENCE INPUT

The AD4111 has true rail-to-rail, integrated, precision unity gain buffers on both ADC reference inputs. The buffers provide the benefit of providing high input impedance and allowing high impedance external sources to be directly connected to the reference inputs. The integrated reference buffers can fully drive the internal reference switch capacitor sampling network, simplifying the reference circuit requirements. Each reference input buffer amplifier is fully chopped, meaning that it minimizes the offset error drift and $1/f$ noise of the buffer. When using a reference such as the [ADR4525](#), these buffers are not required because these references, with proper decoupling, can drive the reference inputs directly.

CLOCK SOURCE

The AD4111 uses a nominal master clock of 2 MHz. The AD4111 can source its sampling clock from one of three sources:

- An internal oscillator.
- An external crystal (use a 16 MHz crystal automatically divided internally to set the 2 MHz clock).
- An external clock source.

All output data rates listed in the data sheet relate to a master clock rate of 2 MHz. Using a lower clock frequency from, for instance, an external source scales any listed data rate proportionally. To achieve the specified data rates, particularly rates for rejection of 50 Hz and 60 Hz, use a 2 MHz clock. The source of the master clock is selected by setting the CLOCKSEL bits (Bits[3:2]) in the ADC mode register, as shown in Table 20. The default operation on power-up and reset of the AD4111 is to operate with the internal oscillator. It is possible to fine tune the output data rate and filter notch at low output data rates using the SINC3_MAPx bits.

Internal Oscillator

The internal oscillator runs at 16 MHz and is internally divided down to 2 MHz for the modulator and can be used as the ADC master clock. The internal oscillator is the default clock source for the AD4111 and is specified with an accuracy of -2.5% to $+2.5\%$.

There is an option to allow the internal clock oscillator to be output on the XTAL2/CLKIO pin. The clock output is driven to the IOVDD logic level. This option can affect the dc performance of the AD4111 due to the disturbance introduced by the output driver. The extent to which the performance is affected depends on the IOVDD voltage supply. Higher IOVDD voltages create a wider logic output swing from the driver and affect performance to a greater extent. This effect is further exaggerated if the IOSTRENGTH bit is set at higher IOVDD levels (see Table 27 for more information).

External Crystal

If higher precision, lower jitter clock sources are required, the AD4111 can use an external crystal to generate the master clock. The crystal is connected to the XTAL1 and XTAL2/CLKIO pins. A recommended crystal for use is the FA-20H, a 16 MHz, 10 ppm, 9 pF crystal from Epson-Toyocom that is available in a surface-mount package. As shown in Figure 40, insert two capacitors (CX1 and CX2) from the traces connecting the crystal to the XTAL1 and XTAL2/CLKIO pins. These capacitors allow circuit tuning. Connect these capacitors to the DGND pin. The value for these capacitors depends on the length and capacitance of the trace connections between the crystal and the XTAL1 and XTAL2/CLKIO pins. Therefore, the values of these capacitors differ depending on the PCB layout and the crystal used.

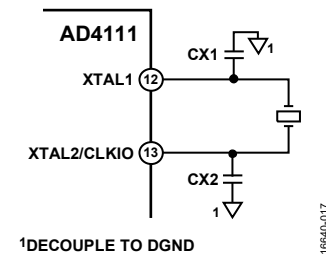

Figure 40. External Crystal Connections

The external crystal circuitry can be sensitive to the SCLK edges, depending on the SCLK frequency, IOVDD voltage, crystal circuitry layout, and the crystal used. During crystal startup, any disturbances caused by the SCLK edges may cause double edges on the crystal input, resulting in invalid conversions until the crystal voltage has reached a high enough level such that any interference from the SCLK edges is insufficient to cause double clocking. This double clocking can be avoided by ensuring that the crystal circuitry has reached a sufficient voltage level after startup before applying any SCLK.

Because of the nature of the crystal circuitry, it is recommended that empirical testing of the circuit be performed under the required conditions, with the final PCB layout and crystal, to ensure correct operation.

External Clock

The AD4111 can also use an externally supplied clock. In systems where an externally supplied clock is used, the external clock is routed to the XTAL2/CLKIO pin. In this configuration, the XTAL2/CLKIO pin accepts the externally sourced clock and routes it to the modulator. The logic level of this clock input is defined by the voltage applied to the IOVDD pin.

DIGITAL FILTER

The AD4111 has three flexible filter options to allow optimization of noise, settling time, and rejection:

- The sinc5 + sinc1 filter.
- The sinc3 filter.
- Enhanced 50 Hz and 60 Hz rejection filters.

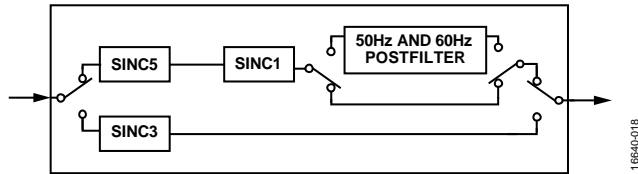

Figure 41. Digital Filter Block Diagram

The filter and output data rate are configured by setting the appropriate bits in the filter configuration register for the selected setup. Each channel can use a different setup and therefore, a different filter and output data rate. See the Register Details section for more information.

SINC5 + SINC1 FILTER

The sinc5 + sinc1 filter is targeted at multiplexed applications and achieves single cycle settling at output data rates of 2.6 kSPS and less. The sinc5 block output is fixed at the maximum rate of 31.25 kSPS, and the sinc1 block output data rate can be varied to control the final ADC output data rate. Figure 42 shows the frequency domain response of the sinc5 + sinc1 filter at a 50 SPS output data rate. The sinc5 + sinc1 filter has a slow roll-off over frequency and narrow notches.

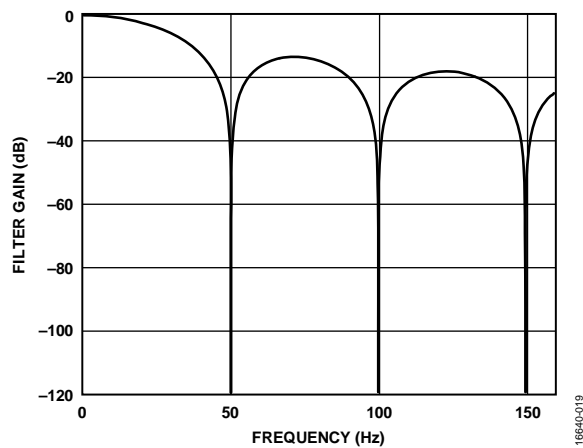

Figure 42. Sinc5 + Sinc1 Filter Response at 50 SPS ODR

The output data rates with the accompanying settling time and rms noise for the sinc5 + sinc1 filter are shown in in Table 6 and Table 7.

SINC3 FILTER

The sinc3 filter achieves the best single-channel noise performance at lower rates and is, therefore, most suitable for single-channel applications. The sinc3 filter always has a settling time equal to

$$t_{SETTLE} = 3/Output\ Data\ Rate$$

Figure 43 shows the frequency domain filter response for the sinc3 filter. The sinc3 filter has good roll-off over frequency and has wide notches for good notch frequency rejection.

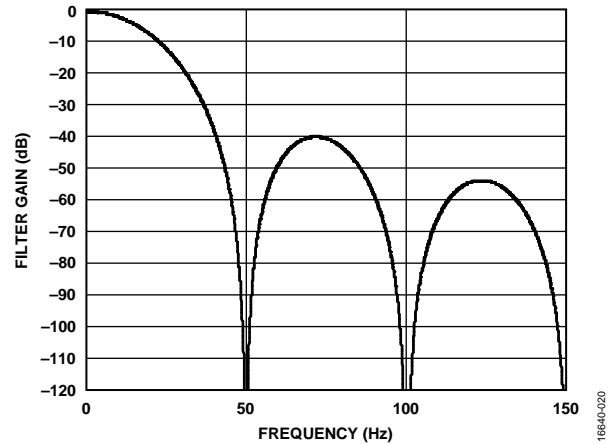

Figure 43. Sinc3 Filter Response

The output data rates with the accompanying settling time and rms noise for the sinc3 filter are shown in Table 8 and Table 9. It is possible to fine tune the output data rate for the sinc3 filter by setting the SINC3_MAPx bit in the filter configuration registers. If this bit is set, the mapping of the filter register changes to directly program the decimation rate of the sinc3 filter. All other options are eliminated. The data rate when on a single channel can be calculated using the following equation:

$$Output\ Data\ Rate = f_{MOD}/(32 \times FILTCONx[14:0])$$

where:

f_{MOD} is the modulator rate (MCLK/2) and is equal to 1 MHz.
 $FILTCONx[14:0]$ are the contents on the filter configuration registers, excluding the MSB.

For example, an output data rate of 50 SPS can be achieved with SINC3_MAPx enabled by setting the FILTCONx[14:0] bits to a value of 625.

SINGLE CYCLE SETTling

The AD4111 can be configured by setting the SING_CYC bit in the ADC mode register so that only fully settled data is output, thus effectively putting the ADC into a single cycle settling mode. This mode achieves single cycle settling by reducing the output data rate to be equal to the settling time of the ADC for the selected output data rate. This bit has no effect with the sinc5 + sinc1 filter at output data rates of 2.6 kSPS and less or when multiple channels are enabled.

Figure 44 shows a step on the analog input with single cycle settling mode disabled and the sinc3 filter selected. The analog input requires at least three cycles after the step change for the output to reach the final settled value.

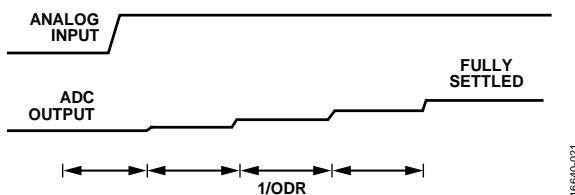

Figure 44. Step Input Without Single Cycle Settling

Figure 45 shows the same step on the analog input but with single cycle settling enabled. The analog input requires at least a single cycle for the output to be fully settled. The output data

rate, as indicated by the $\overline{\text{RDY}}$ signal, is now reduced to equal the settling time of the filter at the selected output data rate.

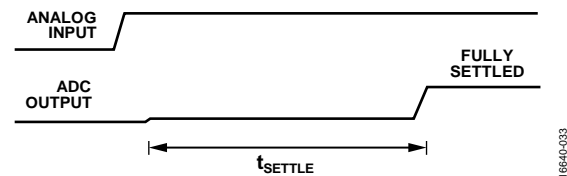

Figure 45. Step Input with Single Cycle Settling

ENHANCED 50 Hz AND 60 Hz REJECTION FILTERS

The enhanced filters provide rejection of 50 Hz and 60 Hz simultaneously and allow the user to trade off settling time and rejection. These filters can operate at up to 27.27 SPS or can reject up to 90 dB of 50 Hz \pm 1 Hz and 60 Hz \pm 1 Hz interference. These filters are operated by postfiltering the output of the sinc5 + sinc1 filter. For this reason, the sinc5 + sinc1 filter must be selected when using the enhanced filters to achieve the specified settling time and noise performance. Table 21 and Table 22 show the output data rates with the accompanying settling time, rejection, and rms noise. Figure 46 to Figure 53 show the frequency domain plots of the responses from the enhanced filters.

Table 21. Enhanced Filters Output Data Rate, Voltage Input Noise, Settling Time, and Rejection Using the Enhanced Filters

Output Data Rate (SPS)	Settling Time (ms)	Simultaneous Rejection of 50 Hz \pm 1 Hz and 60 Hz \pm 1 Hz (dB) ¹	Noise (μ V rms)	Peak-to-Peak Resolution (Bits)	Comments
27.27	36.67	47	6.44	19.1	See Figure 46 and Figure 49
25	40.0	62	6.09	19.2	See Figure 47 and Figure 50
20	50.0	85	5.54	19.35	See Figure 48 and Figure 51
16.667	60.0	90	5.38	19.51	See Figure 52 and Figure 53

¹ Master clock = 2.00 MHz.

Table 22. Enhanced Filters Output Data Rate, Current Input Noise, Settling Time, and Rejection Using the Enhanced Filters

Output Data Rate (SPS)	Settling Time (ms)	Simultaneous Rejection of 50 Hz \pm 1 Hz and 60 Hz \pm 1 Hz (dB) ¹	Noise (nA rms)	Peak-to-Peak Resolution (Bits)	Comments
27.27	36.67	47	7.69	21.4	See Figure 46 and Figure 49
25	40.0	62	7.68	21.2	See Figure 47 and Figure 50
20	50.0	85	7.26	21.7	See Figure 48 and Figure 51
16.667	60.0	90	7.25	21.7	See Figure 52 and Figure 53

¹ Master clock = 2.00 MHz.

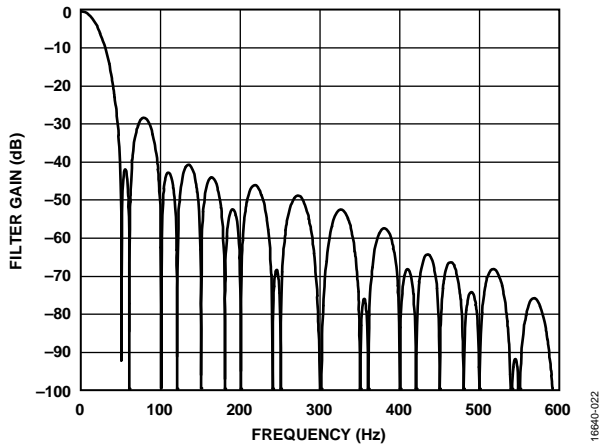

Figure 46. 27.27 SPS ODR, 36.67 ms Settling Time

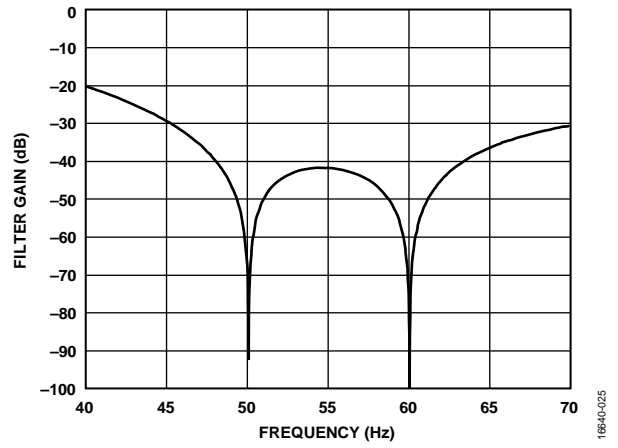

Figure 49. 27.27 SPS ODR, 36.67 ms Settling Time (40 Hz to 70 Hz)

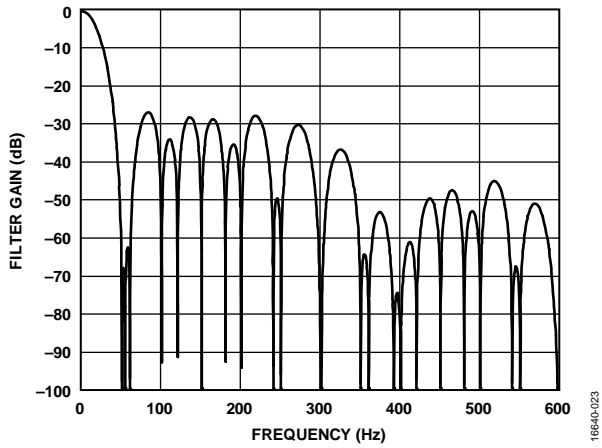

Figure 47. 25 SPS ODR, 40 ms Settling Time

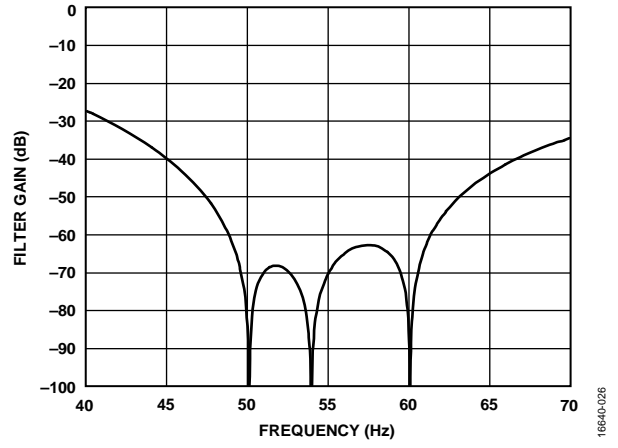

Figure 50. 25 SPS ODR, 40 ms Settling Time (40 Hz to 70 Hz)

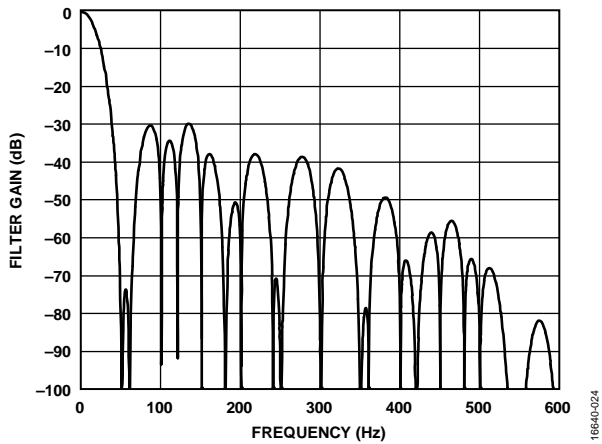

Figure 48. 20 SPS ODR, 50 ms Settling Time

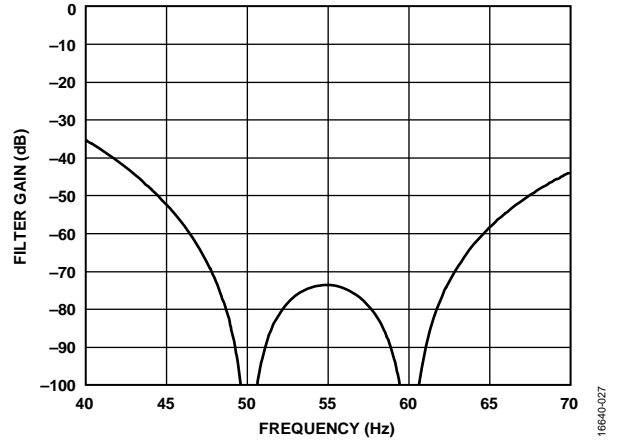

Figure 51. 20 SPS ODR, 50 ms Settling Time (40 Hz to 70 Hz)

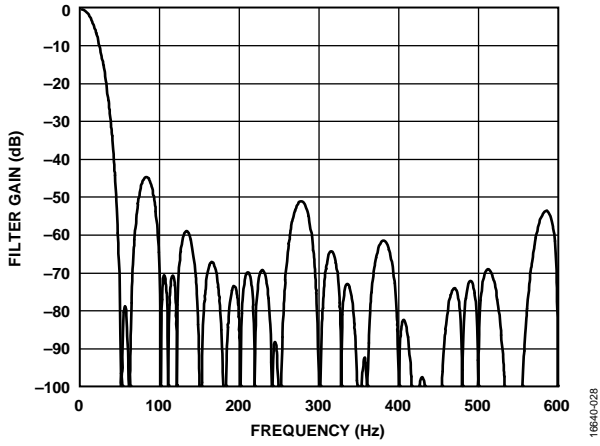

Figure 52. 16.667 SPS ODR, 60 ms Settling Time

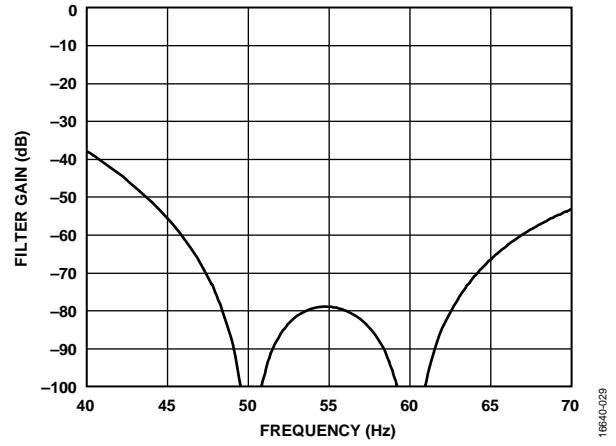

Figure 53. 16.667 SPS ODR, 60 ms Settling Time (40 Hz to 70 Hz)

OPERATING MODES

The AD4111 has a number of operating modes that can be set from the ADC mode register and interface mode register (see Table 26 and Table 27). These modes are as follows:

- Continuous conversion mode
- Continuous read mode
- Single conversion mode
- Standby mode
- Power-down mode
- Calibration modes (four)

CONTINUOUS CONVERSION MODE

Continuous conversion mode is the default power-up mode. The AD4111 converts continuously, and the $\overline{\text{RDY}}$ bit in the status register goes low each time a conversion is complete. If $\overline{\text{CS}}$ is low, the $\overline{\text{RDY}}$ output also goes low when a conversion is complete. To read a conversion, write to the communications register to indicate that the next operation is a read of the data register. When the data-word has been read from the data register,

the $\text{DOUT}/\overline{\text{RDY}}$ pin goes high. The user can read this register additional times, if required. However, ensure that the data register is not being accessed at the completion of the next conversion. Otherwise, the new conversion word is lost.

When several channels are enabled, the ADC automatically sequences through the enabled channels, performing one conversion on each channel. When all the channels are converted, the sequence starts again with the first channel. The channels are converted in order from the lowest enabled channel to the highest enabled channel. The data register is updated as soon as each conversion is available. The $\overline{\text{RDY}}$ output pulses low each time a conversion is available. The user can then read the conversion while the ADC converts the next enabled channel.

If the DATA_STAT bit in the interface mode register is set to 1, the contents of the status register, along with the conversion data, are output each time the data register is read. The four LSBs of the status register indicates the channel to which the conversion corresponds.

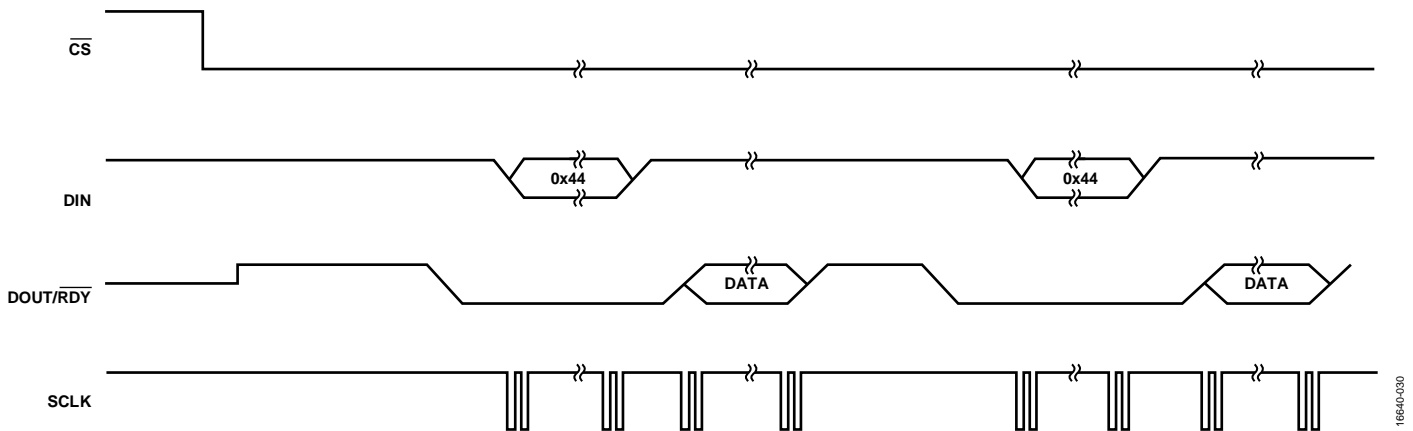

Figure 54. Continuous Conversion Mode

16840-030

CONTINUOUS READ MODE

In continuous read mode, it is not required to write to the communications register before reading ADC data. Apply only the required number of SCLKs after the $\overline{\text{RDY}}$ output goes low to indicate the end of a conversion. When the conversion is read, the $\overline{\text{RDY}}$ output returns high until the next conversion is available. In this mode, the data can be read only once. Ensure that the data-word is read before the next conversion is complete. If the user has not read the conversion before the completion of the next conversion or if insufficient serial clocks are applied to the AD4111 to read the data-word, the serial output register is reset shortly before the next conversion is complete, and the new conversion is placed in the output serial register. The ADC must be configured for continuous conversion mode to use continuous read mode. To enable continuous read mode, set the CONTREAD bit in the interface

mode register. When this bit is set, the only serial interface operations possible are reads from the data register. To exit continuous read mode, issue a dummy read of the ADC data register command (0x44) while the $\overline{\text{RDY}}$ output is low. Alternatively, apply a software reset (that is, 64 SCLKs with $\overline{\text{CS}} = 0$ and $\text{DIN} = 1$) to reset the ADC and all register contents. The dummy read and the software reset are the only commands that the interface recognizes after it is placed in continuous read mode. Hold DIN low in continuous read mode until an instruction is to be written to the device.

If multiple ADC channels are enabled, each channel is output in turn, with the status bits being appended to the data if the DATA_STAT bit is set in the interface mode register. The four LSBs of the status register indicates the channel to which the conversion corresponds.

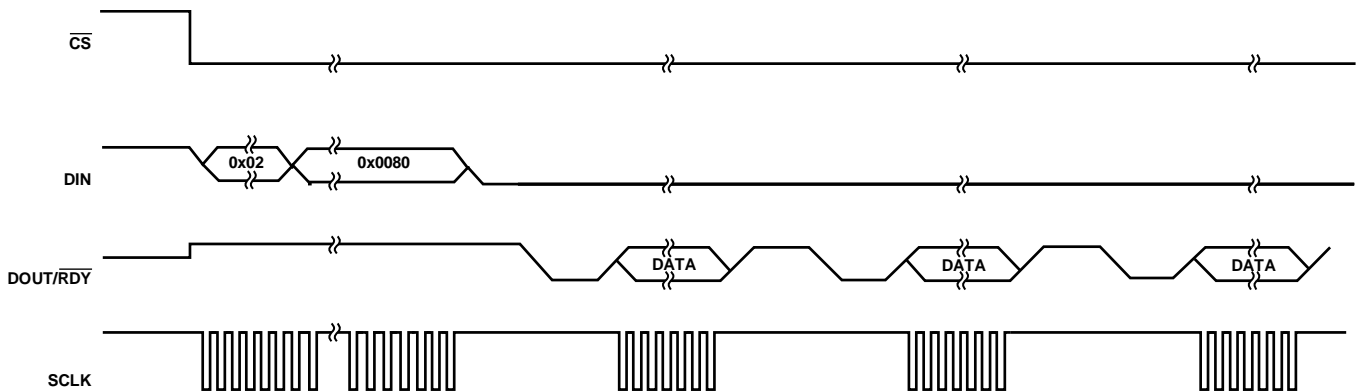

Figure 55. Continuous Read Mode

16640-031

SINGLE CONVERSION MODE

In single conversion mode, the AD4111 performs a single conversion and is placed in standby mode after the conversion is complete. The $\overline{\text{RDY}}$ output goes low to indicate the completion of a conversion. When the data-word has been read from the data register, the $\overline{\text{RDY}}$ output goes high. The data register can be read several times, if required, even when the $\overline{\text{RDY}}$ output goes high.

If several channels are enabled, the ADC automatically sequences through the enabled channels and performs a conversion on each channel. When the first conversion is started, the $\overline{\text{RDY}}$ output goes high and remains high until a valid conversion is available and CS is low. When the conversion is available, the

$\overline{\text{RDY}}$ output goes low. The ADC then selects the next channel and begins a conversion. The user can read the present conversion while the next conversion is being performed. When the next conversion is complete, the data register is updated; therefore, the user has a limited period in which to read the conversion. When the ADC has performed a single conversion on each of the selected channels, it returns to standby mode.

If the DATA_STAT bit in the interface mode register is set to 1, the contents of the status register, along with the conversion, are output each time the data register is read. The four LSBs of the status register indicate the channel to which the conversion corresponds.

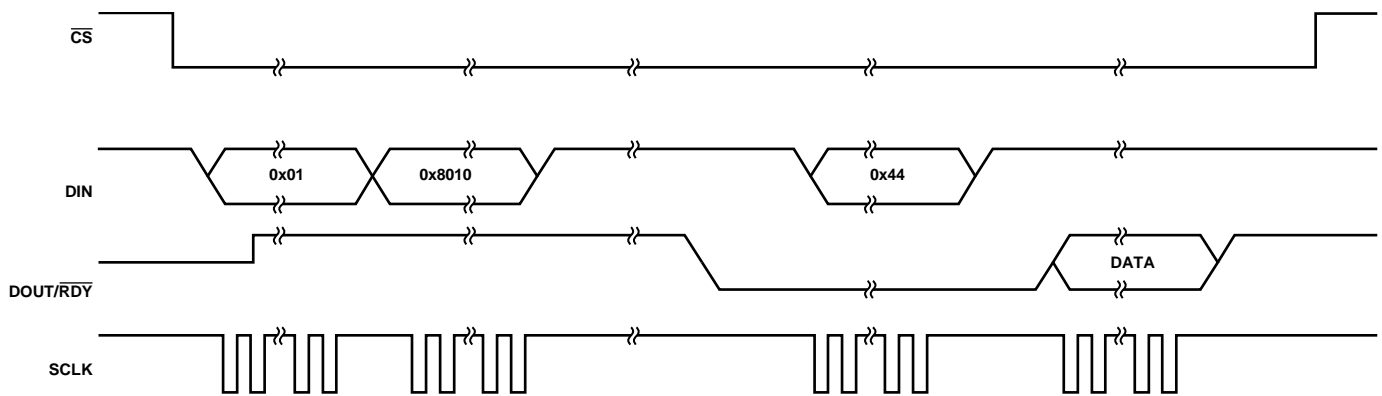

Figure 56. Single Conversion Mode

16640-032

STANDBY AND POWER-DOWN MODES

In standby mode, most blocks are powered down. The LDO regulators remain active so that the registers maintain their contents. The crystal oscillator remains active if selected. To power down the clock in standby mode, set the CLOCKSEL bits in the ADC mode register to 00 (internal oscillator mode).

In power-down mode, all blocks are powered down, including the LDO regulators. All registers lose their contents, and the GPIO outputs are placed in three-state. To prevent accidental entry to power-down mode, the ADC must first be placed in standby mode. Exiting power-down mode requires 64 SCLKs with $\overline{CS} = 0$ and $DIN = 1$, that is, a serial interface reset. A delay of 500 μs is recommended before issuing a subsequent serial interface command to allow the LDO regulator to power up.

CALIBRATION

The AD4111 allows a two-point calibration to be performed to eliminate any offset and gain errors. Four calibration modes are used to eliminate these offset and gain errors on a per setup basis:

- Internal zero-scale calibration mode
- Internal full-scale calibration mode
- System zero-scale calibration mode
- System full-scale calibration mode

Only one channel can be active during calibration. After each conversion, the ADC conversion result is scaled using the ADC calibration registers before being written to the data register.

The default value of the offset register is 0x800000, and the nominal value of the gain register is factory calibrated for the current channels; therefore, this value can vary from 0x500000 to 0x5FFFFFF. When enabling a voltage channel, run an internal full-scale calibration. The following equations show the calculations that are used. In unipolar mode, the ideal relationship (that is, not taking into account the ADC gain error and offset error) is as follows:

$$Data = ((0.075 \times V_{IN}/V_{REF}) \times 2^{23} - (Offset - 0x800000)) \times (Gain/0x400000) \times 2$$

For a current input, the ideal relationship is as follows:

$$Data = ((0.75 \times (I_{IN} \times 50)/V_{REF}) \times 2^{12} - (Offset - 0x800000)) \times (Gain/0x400000) \times 2$$

In bipolar mode, the ideal relationship (that is, not taking into account the ADC gain error and offset error) is as follows:

$$Data = ((0.075 \times V_{IN}/V_{REF}) \times 2^{23} - (Offset - 0x800000)) \times (Gain/0x400000) + 0x800000$$

For a current input, the ideal relationship is as follows:

$$Data = ((0.75 \times (I_{IN} \times 50)/V_{REF}) \times 2^{23} - (Offset - 0x800000)) \times (Gain/0x400000) + 0x800000$$

To start a calibration, write the relevant value to the mode bits in the ADC mode register. The DOUT/RDY pin and the RDY bit in the status register go high when the calibration initiates. When

the calibration is complete, the contents of the corresponding offset or gain register are updated, the RDY bit in the status register is reset and the RDY output pin returns low (if \overline{CS} is low), and the AD4111 reverts to standby mode.

During an internal offset calibration both modulator inputs are connected internally to the selected negative analog input pin. Therefore, it is necessary to ensure that the voltage on the selected negative analog input pin does not exceed the allowed limits and is free from excessive noise and interference. To perform an internal full-scale calibration, a full-scale input voltage is automatically connected to the ADC input for this calibration. Internal full-scale calibrations must only be performed on voltage inputs. Do not perform internal full-scale calibrations on the current inputs.

However, for system calibrations, the system zero-scale (offset) and system full-scale (gain) voltages must be applied to the input pins before initiating the calibration modes. As a result, errors external to the AD4111 are removed. The calibration range of the ADC gain for a system full-scale calibration on a voltage input is from $3.75 \times V_{REF}$ to $10.5 \times V_{REF}$. However, if $10.5 \times V_{REF}$ is greater than the absolute input voltage specification for the applied AVDD, use the specification as the upper limit instead of $10.5 \times V_{REF}$ (see the Specifications section).

Current inputs are factory calibrated. Therefore, it is not necessary to perform a system calibration. However if a system calibration is required, apply a full-scale value of 24 mA for a $V_{REF} = 2.5 \text{ V}$.

An internal zero-scale calibration only removes the offset error of the ADC core. It does not remove error from the resistive front end. A system zero-scale calibration reduces the offset error to the order of the noise on that channel.

From an operational point of view, treat a calibration like another ADC conversion. An offset calibration, if required, must always be performed before a full-scale calibration. Set the system software to monitor the RDY bit in the status register or the RDY output to determine the end of a calibration via a polling sequence or an interrupt driven routine. All calibrations require a time equal to the settling time of the selected filter and output data rate to be completed.

Any calibration can be performed at any output data rate. Using lower output data rates results in better calibration accuracy and is accurate for all output data rates. A new offset calibration is required for a given channel if the reference source for that channel is changed.

The AD4111 provides the user with access to the on-chip calibration registers, allowing the microprocessor to read the calibration coefficients of the device and to write its own calibration coefficients. A read or write of the offset and gain registers can be performed at any time except during an internal or self calibration.

DIGITAL INTERFACE

The programmable functions of the AD4111 are accessible via the SPI serial interface. The serial interface of the AD4111 consists of four signals: \overline{CS} , DIN, SCLK, and DOUT/ \overline{RDY} . The DIN line transfers data into the on-chip registers. The DOUT output accesses data from the on-chip registers. SCLK is the serial clock input for the device. All data transfers (either on DIN or on DOUT) occur with respect to the SCLK signal.

The DOUT/ \overline{RDY} pin also functions as a data ready signal, with the line going low if \overline{CS} is low when a new data-word is available in the data register. The pin is reset high when a read operation from the data register is complete. The \overline{RDY} output also goes high before updating the data register to indicate when not to read from the device to ensure that a data read is not attempted while the register is being updated. Take care to avoid reading from the data register when \overline{RDY} is about to go low. The best method to ensure that no data read occurs is to always monitor the \overline{RDY} output. Start reading the data register as soon as \overline{RDY} goes low, and ensure a sufficient SCLK rate, such that the read is completed before the next conversion result. \overline{CS} is used to select a device. \overline{CS} can be used to decode the AD4111 in systems where several components are connected to the serial bus.

Figure 2 and Figure 3 show timing diagrams for interfacing to the AD4111 using \overline{CS} to decode the device. Figure 2 shows the timing for a read operation from the AD4111, and Figure 3 shows the timing for a write operation to the AD4111. It is possible to read from the data register several times, even though the \overline{RDY} output returns high after the first read operation. However, take care to ensure that the read operations are completed before the next output update occurs. In continuous read mode, the data register can be read only once.

The serial interface can operate in 3-wire mode by tying \overline{CS} low. In this case, the SCLK, DIN, and DOUT/ \overline{RDY} lines are used to communicate with the AD4111. The end of the conversion can also be monitored using the \overline{RDY} bit in the status register.

The serial interface can be reset by writing 64 SCLKs with $\overline{CS} = 0$ and DIN = 1. A reset returns the interface to the state in which it expects a write to the communications register. This operation resets the contents of all registers to their power-on values. Following a reset, allow a period of 500 μ s before addressing the serial interface.

CHECKSUM PROTECTION

The AD4111 has a checksum mode that can be used to improve interface robustness. Using the checksum ensures that only valid data is written to a register and allows data read from a register to be validated. If an error occurs during a register write, the

CRC_ERROR bit is set in the status register. However, to ensure that the register write was completed. It is important to read back the register and verify the checksum.

For CRC checksum calculations during a write operation, the following polynomial is always used:

$$x^8 + x^2 + x + 1$$

During read operations, the user can select between this polynomial and a similar exclusive OR (XOR) function. The XOR function requires less time to process on the host microcontroller than the polynomial-based checksum. The CRC_EN bits in the interface mode register enable and disable the checksum and allow the user to select between the polynomial check and the simple XOR check.

The checksum is appended to the end of each read and write transaction. The checksum calculation for the write transaction is calculated using the 8-bit command word and the 8-bit to 24-bit data. For a read transaction, the checksum is calculated using the command word and the 8-bit to 32-bit data output. Figure 57 and Figure 58 show SPI write and read transactions, respectively.

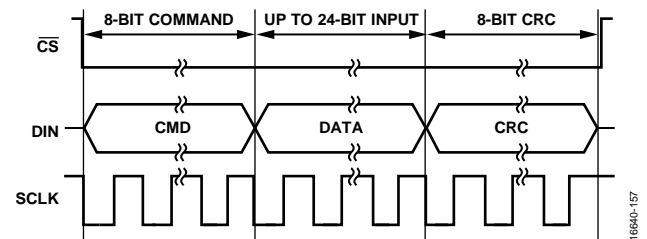

Figure 57. SPI Write Transaction with CRC

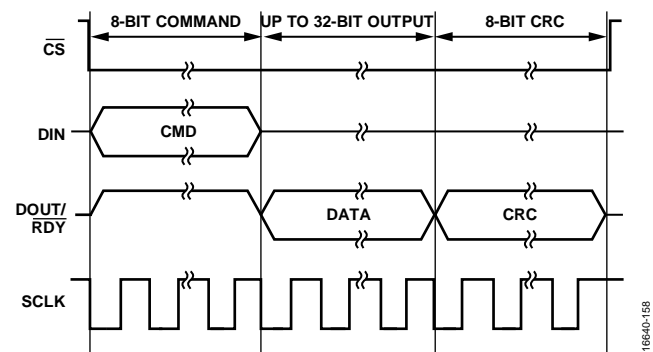

Figure 58. SPI Read Transaction with CRC

If checksum protection is enabled when continuous read mode is active, there is an implied read data command of 0x44 before every data transmission that must be accounted for when calculating the checksum value. The checksum protection ensures a nonzero checksum value even if the ADC data equals 0x000000.

CRC CALCULATION

Polynomial

The checksum, which is eight bits wide, is generated using the following polynomial:

$$x^8 + x^2 + x + 1$$

To generate the checksum, the data is left shifted by eight bits to create a number ending in eight Logic 0s. The polynomial is aligned so that its MSB is adjacent to the leftmost Logic 1 of the data. An exclusive OR (XOR) function is applied to the data to produce a new, shorter number. The polynomial is again aligned

so that its MSB is adjacent to the leftmost Logic 1 of the new result, and the procedure is repeated. This process is repeated until the original data is reduced to a value less than the polynomial. This value is the 8-bit checksum.

Example of a Polynomial CRC Calculation—24-Bit Word: 0x654321 (Eight Command Bits and 16-Bit Data)

An example of generating the 8-bit checksum using the polynomial-based checksum is as follows.

Initial value	011001010100001100100001	
	01100101010000110010000100000000	left shifted eight bits
$x^8 + x^2 + x + 1 =$	100000111	polynomial
	100100100000110010000100000000	XOR result
	100000111	polynomial
	1000110001100100001000000000	XOR result
	100000111	polynomial
	111111100100001000000000	XOR result
	100000111	polynomial value
	111110111000010000000000	XOR result
	100000111	polynomial value
	1111000000001000000000	XOR result
	100000111	polynomial value
	1110011100010000000000	XOR result
	100000111	polynomial value
	11001001001000000000	XOR result
	100000111	polynomial value
	10010101010000000000	XOR result
	100000111	polynomial value
	1011011000000000	XOR result
	100000111	polynomial value
	11010110000000	XOR result
	100000111	polynomial value
	101010110000	XOR result
	100000111	polynomial value
	1010001000	XOR result
	100000111	polynomial value
	10000110	checksum = 0x86.

XOR Calculation

The checksum, which is eight bits wide, is generated by splitting the data into bytes and then performing an XOR of the bytes.

Example of an XOR Calculation—24-Bit Word: 0x654321 (Eight Command Bits and 16-Bit Data)

Using the example shown in the Polynomial section, divide the checksum into three bytes: 0x65, 0x43, and 0x21.

The XOR calculation is then as follows:

01100101	0x65
01000011	0x43
00100110	XOR result
00100001	0x21
00000111	CRC

INTEGRATED FUNCTIONS

The AD4111 has a number of integrated functions.

GENERAL-PURPOSE OUTPUTS

The AD4111 has two general-purpose digital output pins (GPO0, GPO1). The GPO pins are enabled using the OP_EN0_1 bit in the GPIOCON register.

The GP_DATA0 and GP_DATA1 bits determines the logic level output at the pin, respectively. The logic levels for these pins are referenced to AVDD and AVSS. Therefore, outputs have an amplitude of either 5 V or 3.3 V depending on the AVDD – AVSS voltage.

The ERROR pin can also be used as a general-purpose output if the ERR_EN bits in the GPIOCON register are set to 11. In this configuration, the ERR_DAT bit in the GPIOCON register determines the logic level output at the ERROR pin. The logic level for the pin is referenced to IOVDD and DGND, and the ERROR pin has an active pull-up resistor.

DELAY

It is possible to insert a programmable delay before the AD4111 begins to take samples. This delay allows an external amplifier or multiplexer to settle and can also alleviate the specification requirements for the external amplifier or multiplexer. Eight programmable settings, ranging from 0 μ s to 8 ms, can be set using the delay bits in the ADC mode register (Register 0x01, Bits[10:8]).

16-BIT/24-BIT CONVERSIONS

By default, the AD4111 generates 24-bit conversions. However, the width of the conversions can be reduced to 16 bits. Setting Bit WL16 in the interface mode register to 1 rounds all data conversions to 16 bits. Clearing this bit sets the width of the data conversions to 24 bits.

DOUT_RESET

The serial interface uses a shared DOUT/RDY pin. By default, this pin outputs the RDY signal. During a data read, this pin outputs the data from the register being read. After the read is complete, the pin reverts to outputting the RDY signal after a short fixed period of time (t_7). However, this time may be too short for some microcontrollers and can be extended until the CS pin is brought high by setting the DOUT_RESET bit in the interface mode register to 1. This setting means that CS must frame each read operation and complete the serial interface transaction.

SYNCHRONIZATION

Normal Synchronization

When the SYNC_EN bit in the GPIOCON register is set to 1, the SYNC pin functions as a synchronization pin. The SYNC input allows the user to reset the modulator and the digital filter without affecting any of the setup conditions on the device. This reset allows the user to start gathering samples of the analog input from a known point in time, that is, the rising edge of SYNC. This pin must be low for at least one master

clock cycle to ensure that synchronization occurs. If multiple channels are enabled, the sequencer is reset to the first enabled channel.

If multiple AD4111 devices are operated from a common master clock, they can be synchronized so that their data registers are updated simultaneously. Synchronization is normally done after each AD4111 has performed its own calibration or has calibration coefficients loaded into its calibration registers. A falling edge on the SYNC pin resets the digital filter and the analog modulator and places the AD4111 into a consistent known state. While the SYNC pin is low, the AD4111 is maintained in this state. On the SYNC rising edge, the modulator and filter are taken out of this reset state, and on the next master clock edge, the device starts to gather input samples again.

The device is taken out of reset on the master clock falling edge following the SYNC low to high transition. Therefore, when multiple devices are being synchronized, take the SYNC pin high on the master clock rising edge to ensure that all devices begin sampling on the master clock falling edge. If the SYNC pin is not taken high in sufficient time, it is possible to have a difference of one master clock cycle between the devices, that is, the instant at which conversions are available differs from device to device by a maximum of one master clock cycle.

The SYNC input can also be used as a start conversion command for a single channel when in normal synchronization mode. In this mode, the rising edge of the SYNC input starts a conversion, and the falling edge of the RDY output indicates when the conversion is complete. The settling time of the filter is required for each data register update. After the conversion is complete, bring the SYNC input low in preparation for the next conversion start signal.

Alternate Synchronization

In alternate synchronization mode, the SYNC input operates as a start conversion command when several channels of the AD4111 are enabled. Setting the ALT_SYNC bit in the interface mode register to 1 enables an alternate synchronization scheme. When the SYNC input is taken low, the ADC completes the conversion on the enabled channel, selects the next channel in the sequence, and then waits until the SYNC input is taken high to start the conversion. The RDY output goes low when the conversion is complete on the current channel, and the data register is updated with the corresponding conversion. Therefore, the SYNC input does not interfere with the sampling on the currently selected channel but allows the user to control the instant at which the conversion begins on the next channel in the sequence.

Alternate synchronization mode can be used only when several channels are enabled. It is not recommended to use this mode when a single channel is enabled.

ERROR FLAGS

The status register contains three error bits (ADC_ERROR, CRC_ERROR, and REG_ERROR) that flag errors with the ADC conversion, errors with the CRC check, and errors caused by changes in the registers, respectively. In addition, the ERROR output can indicate that an error has occurred.

ADC_ERROR

The ADC_ERROR bit in the status register flags any errors that occur during the conversion process. The flag is set when an over-range or underrange result is output from the ADC. The ADC also outputs all 0s or all 1s when an undervoltage or overvoltage occurs. This flag is reset only when the overvoltage or undervoltage is removed. This flag is not reset by a read of the data register.

CRC_ERROR

If the CRC value that accompanies a write operation does not correspond with the information sent, the CRC_ERROR flag is set. The flag is reset as soon as the status register is explicitly read.

REG_ERROR

The REG_ERROR flag is used in conjunction with the REG_CHECK bit in the interface mode register. When the REG_CHECK bit is set, the AD4111 monitors the values in the on-chip registers. If a bit changes, the REG_ERROR bit is set to 1. Therefore, for writes to the on-chip registers, set the REG_CHECK bit to 0. When the registers have been updated, the REG_CHECK bit can be set to 1. The AD4111 calculates a checksum of the on-chip registers. If one of the register values has changed, the REG_ERROR bit is set to 1. If an error is flagged, the REG_CHECK bit must be set to 0 to clear the REG_ERROR bit in the status register. The register check function does not monitor the data register, status register, or interface mode register.

ERROR Input/Output

The ERROR pin functions as an error input/output pin or as a general-purpose output pin. The ERR_EN bits in the GPIOCON register determine the function of the pin.

When ERR_EN is set to 10, the ERROR pin functions as an open-drain error output. The three error bits in the status register (ADC_ERROR, CRC_ERROR, and REG_ERROR) are OR'ed, inverted, and mapped to the ERROR output. Therefore, the ERROR output indicates that an error has occurred. The status register must be read to identify the error source.

When ERR_EN is set to 01, the ERROR pin functions as an error input. The error output of another component can be connected to the AD4111 ERROR input so that the AD4111 indicates when an error occurs on either itself or the external

component. The value on the ERROR input is inverted and OR'ed with the errors from the ADC conversion, and the result is indicated via the ADC_ERROR bit in the status register. The value of the ERROR input is reflected in the ERR_DAT bit in the GPIO configuration register.

The ERROR input/output is disabled when ERR_EN is set to 00. When the ERR_EN bits are set to 11, the ERROR pin operates as a general-purpose output where the ERR_DAT bit is used to determine the logic level of the pin.

DATA_STAT

The contents of the status register can be appended to each conversion on the AD4111 using the DATA_STAT bit in the IFMODE register. This function is useful if several channels are enabled. Each time a conversion is output, the contents of the status register are appended. The four LSBs of the status register indicate to which channel the conversion corresponds. In addition, the user can determine if any errors are being flagged by the error bits.

IOSTRENGTH

The serial interface can operate with a power supply as low as 2 V. However, at this low voltage, the DOUT/RDY pin may not have sufficient drive strength if there is moderate parasitic capacitance on the board or if the SCLK frequency is high. The IOSTRENGTH bit in the interface mode register increases the drive strength of the DOUT/RDY pin.

INTERNAL TEMPERATURE SENSOR

The AD4111 has an integrated temperature sensor. The temperature sensor can be used as a guide for the ambient temperature at which the device is operating. The ambient temperature can be used for diagnostic purposes or as an indicator of when the application circuit must rerun a calibration routine to take into account a shift in operating temperature. The temperature sensor is selected using the multiplexer and is selected in the same way as an input channel.

The temperature sensor requires that the input buffers be enabled on both inputs and the internal reference be enabled.

To use the temperature sensor, the first step is to calibrate the device in a known temperature (25°C) and take a conversion as a reference point. The temperature sensor has a nominal sensitivity of 477 $\mu\text{V}/\text{K}$. The difference in this ideal slope and the slope measured can calibrate the temperature sensor. The temperature sensor is specified with a $\pm 2^\circ\text{C}$ typical accuracy after calibration at 25°C. Calculate the temperature as follows:

$$\text{Temperature } (^\circ\text{C}) = (\text{Conversion Result} \div 477 \mu\text{V}) - 273.15$$

APPLICATIONS INFORMATION

IEC61000-4-x AND CISPR 11 ROBUSTNESS

PLC and DCS modules often operate in harsh industrial environments and must survive electromagnetic interference (EMI) conditions. To aid the design of electromagnetic compatibility (EMC) capable solutions, the [AN-1572](#) Applications Note is available. [AN-1572](#) details all necessary information on the test procedures used, as well as the layout and board design schematics necessary to design an EMC proven input module for the AD4111. The board ensures that the circuit performance is not permanently affected by radiated radio frequency (RF) or conducted RF disturbances and has sufficient immunity against electrostatic discharge (ESD), electrical fast transients (EFT), and surge as per the IEC61000-4-x standards. The AD4111 was also evaluated for CISPR 11, where the radiated emissions for the board are less than the Class A limits.

GROUNDING AND LAYOUT

The inputs and reference inputs are differential and, therefore, most of the voltages in the analog modulator are common-mode voltages. The high common-mode rejection of the device removes common-mode noise on these inputs. The analog and digital supplies to the AD4111 are independent and separately pinned out to minimize coupling between the analog and digital sections of the device. The digital filter provides rejection of broadband noise on the power supplies, except at integer multiples of the master clock frequency.

The digital filter also removes noise from the analog inputs and reference inputs, provided that these noise sources do not saturate the analog modulator. As a result, the AD4111 is more immune to noise interference than a conventional high resolution converter. However, because the resolution of the AD4111 is high and the noise levels from the converter are so low, take care with regard to grounding and layout.

The PCB that houses the ADC must be designed so that the analog and digital sections are separated and confined to certain areas of the board. A minimum etch technique is

generally best for ground planes because it results in the best shielding.

In any layout, the user must keep in mind the flow of currents in the system, ensuring that the paths for all return currents are as close as possible to the paths the currents took to reach their destinations.

Avoid running digital lines under the device because this couples noise onto the die and allows the analog ground plane to run under the AD4111 to prevent noise coupling. The power supply lines to the AD4111 must use as wide a trace as possible to provide low impedance paths and reduce glitches on the power supply line. Shield fast switching signals like clocks with digital ground to prevent radiating noise to other sections of the board and never run clock signals near the inputs. Avoid crossover of digital and analog signals. Run traces on opposite sides of the board at right angles to each other. This layout reduces the effects of feedthrough on the board. A microstrip technique is by far the best but is not always possible with a double-sided board. In this technique, the component side of the board is dedicated to ground planes, whereas signals are placed on the solder side.

Proper decoupling is important when using high resolution ADCs. The AD4111 has two power supply pins: AVDD and IOVDD. The AVDD pin is referenced to AVSS, and the IOVDD pin is referenced to DGND. Decouple AVDD with a 10 μF tantalum capacitor in parallel with a 0.1 μF capacitor to AVSS on each pin. Place the 0.1 μF capacitor as near as possible to the device on each supply, ideally right up against the device. Decouple IOVDD with a 10 μF tantalum capacitor, in parallel with a 0.1 μF capacitor to DGND. Decouple all inputs to AVSS. If an external reference is used, decouple the REF+ and REF- pins to AVSS.

The AD4111 also has two on-board LDO regulators: one that regulates the AVDD supply, and one that regulates the IOVDD supply. For the REGCAPA pin, it is recommended that 1 μF and 0.1 μF capacitors to AVSS be used. Similarly, for the REGCAPD pin, it is recommended that 1 μF and 0.1 μF capacitors to DGND be used.

REGISTER SUMMARY

Table 23. Register Summary

Reg.	Name	Bits	Bit 7	Bit 6	Bit 5	Bit 4	Bit 3	Bit 2	Bit 1	Bit 0	Reset	RW	
0x00	COMMS	[7:0]	WEN	R/W	RA						0x00	W	
0x00	Status	[7:0]	RDY	ADC_ERROR	CRC_ERROR	REG_ERROR	Channel				0x80	R	
0x01	ADCMODE	[15:8]	REF_EN	Reserved	SING_CYC	Reserved			Delay		0x2000	RW	
		[7:0]	Reserved	Mode			CLOCKSEL		Reserved				
0x02	IFMODE	[15:8]	Reserved			ALT_SYNC	IOSTRENGTH	Reserved		DOUT_RESET	0x0000	RW	
		[7:0]	CONTREAD	DATA_STAT	REG_CHECK	Reserved	CRC_EN		Reserved	WL16			
0x03	REGCHECK	[23:16]	REGISTER_CHECK[23:16]									0x000000	R
		[15:8]	REGISTER_CHECK[15:8]										
		[7:0]	REGISTER_CHECK[7:0]										
0x04	Data	[23:16]	Data [23:16]									0x000000	R
		[15:8]	Data [15:8]										
		[7:0]	Data [7:0]										
0x06	GPIOCON	[15:8]	Reserved	Reserved	OP_EN0_1	OW_EN	SYNC_EN	ERR_EN		ERR_DAT	0x0800	RW	
		[7:0]	GP_DATA1	GP_DATA0	Reserved								
0x07	ID	[15:8]	ID[15:8]									0x30Dx	R
		[7:0]	ID[7:0]										
0x10	CH0	[15:8]	CH_EN0	SETUP_SEL0			Reserved		INPUT0[9:8]		0x8001	RW	
		[7:0]	INPUT0[7:0]										
0x11	CH1	[15:8]	CH_EN1	SETUP_SEL1			Reserved		INPUT1[9:8]		0x0001	RW	
		[7:0]	INPUT1[7:0]										
0x12	CH2	[15:8]	CH_EN2	SETUP_SEL2			Reserved		INPUT2[9:8]		0x0001	RW	
		[7:0]	INPUT2[7:0]										
0x13	CH3	[15:8]	CH_EN3	SETUP_SEL3			Reserved		INPUT3[9:8]		0x0001	RW	
		[7:0]	INPUT3[7:0]										
0x14	CH4	[15:8]	CH_EN4	SETUP_SEL4			Reserved		INPUT4[9:8]		0x0001	RW	
		[7:0]	INPUT4[7:0]										
0x15	CH5	[15:8]	CH_EN5	SETUP_SEL5			Reserved		INPUT5[9:8]		0x0001	RW	
		[7:0]	INPUT5[7:0]										
0x16	CH6	[15:8]	CH_EN6	SETUP_SEL6			Reserved		INPUT6[9:8]		0x0001	RW	
		[7:0]	INPUT6[7:0]										
0x17	CH7	[15:8]	CH_EN7	SETUP_SEL7			Reserved		INPUT7[9:8]		0x0001	RW	
		[7:0]	INPUT7[7:0]										
0x18	CH8	[15:8]	CH_EN8	SETUP_SEL8			Reserved		INPUT8[9:8]		0x0001	RW	
		[7:0]	INPUT8[7:0]										
0x19	CH9	[15:8]	CH_EN9	SETUP_SEL9			Reserved		INPUT9[9:8]		0x0001	RW	
		[7:0]	INPUT9[7:0]										
0x1A	CH10	[15:8]	CH_EN10	SETUP_SEL10			Reserved		INPUT10[9:8]		0x0001	RW	
		[7:0]	Input10[7:0]										
0x1B	CH11	[15:8]	CH_EN11	SETUP_SEL11			Reserved		INPUT11[9:8]		0x0001	RW	
		[7:0]	INPUT11[7:0]										
0x1C	CH12	[15:8]	CH_EN12	SETUP_SEL12			Reserved		INPUT12[9:8]		0x0001	RW	
		[7:0]	INPUT12[7:0]										
0x1D	CH13	[15:8]	CH_EN13	SETUP_SEL13			Reserved		INPUT13[9:8]		0x0001	RW	
		[7:0]	INPUT13[7:0]										
0x1E	CH14	[15:8]	CH_EN14	SETUP_SEL14			Reserved		INPUT14[9:8]		0x0001	RW	
		[7:0]	INPUT14[7:0]										
0x1F	CH15	[15:8]	CH_EN15	SETUP_SEL15			Reserved		INPUT15[9:8]		0x0001	RW	
		[7:0]	INPUT15[7:0]										
0x20	SETUPCON0	[15:8]	Reserved			BI_UNIPOLAR0	REFBUF0+	REFBUF0-	INBUF0		0x1000	RW	
		[7:0]	Reserved	Reserved	REF_SEL0		Reserved						
0x21	SETUPCON1	[15:8]	Reserved			BI_UNIPOLAR1	REFBUF1+	REFBUF1-	INBUF1		0x1000	RW	
		[7:0]	Reserved	Reserved	REF_SEL1		Reserved						

Reg.	Name	Bits	Bit 7	Bit 6	Bit 5	Bit 4	Bit 3	Bit 2	Bit 1	Bit 0	Reset	RW
0x22	SETUPCON2	[15:8]	Reserved			BI_UNIPOLAR2	REFBUF2+	REFBUF2-	INBUF2		0x1000	RW
		[7:0]	Reserved	Reserved	REF_SEL2		Reserved					
0x23	SETUPCON3	[15:8]	Reserved			BI_UNIPOLAR3	REFBUF3+	REFBUF3-	INBUF3		0x1000	RW
		[7:0]	Reserved	Reserved	REF_SEL3		Reserved					
0x24	SETUPCON4	[15:8]	Reserved			BI_UNIPOLAR4	REFBUF4+	REFBUF4-	INBUF4		0x1000	RW
		[7:0]	Reserved	Reserved	REF_SEL4		Reserved					
0x25	SETUPCON5	[15:8]	Reserved			BI_UNIPOLAR5	REFBUF5+	REFBUF5-	INBUF5		0x1000	RW
		[7:0]	Reserved	Reserved	REF_SEL5		Reserved					
0x26	SETUPCON6	[15:8]	Reserved			BI_UNIPOLAR6	REFBUF6+	REFBUF6-	INBUF6		0x1000	RW
		[7:0]	Reserved	Reserved	REF_SEL6		Reserved					
0x27	SETUPCON7	[15:8]	Reserved			BI_UNIPOLAR7	REFBUF7+	REFBUF7-	INBUF7		0x1000	RW
		[7:0]	Reserved	Reserved	REF_SEL7		Reserved					
0x28	FILTCON0	[15:8]	SINC3_MAP0	Reserved			ENHFILTEN0	ENHFILT0		0x0500	RW	
		[7:0]	Reserved	ORDER0		ODR0						
0x29	FILTCON1	[15:8]	SINC3_MAP1	Reserved			ENHFILTEN1	ENHFILT1		0x0500	RW	
		[7:0]	Reserved	ORDER1		ODR1						
0x2A	FILTCON2	[15:8]	SINC3_MAP2	Reserved			ENHFILTEN2	ENHFILT2		0x0500	RW	
		[7:0]	Reserved	ORDER2		ODR2						
0x2B	FILTCON3	[15:8]	SINC3_MAP3	Reserved			ENHFILTEN3	ENHFILT3		0x0500	RW	
		[7:0]	Reserved	ORDER3		ODR3						
0x2C	FILTCON4	[15:8]	SINC3_MAP4	Reserved			ENHFILTEN4	ENHFILT4		0x0500	RW	
		[7:0]	Reserved	ORDER4		ODR4						
0x2D	FILTCON5	[15:8]	SINC3_MAP5	Reserved			ENHFILTEN5	ENHFILT5		0x0500	RW	
		[7:0]	Reserved	ORDER5		ODR5						
0x2E	FILTCON6	[15:8]	SINC3_MAP6	Reserved			ENHFILTEN6	ENHFILT6		0x0500	RW	
		[7:0]	Reserved	ORDER6		ODR6						
0x2F	FILTCON7	[15:8]	SINC3_MAP7	Reserved			ENHFILTEN7	ENHFILT7		0x0500	RW	
		[7:0]	Reserved	ORDER7		ODR7						
0x30	OFFSET0	[23:0]					OFFSET0[23:0]				0x800000	RW
0x31	OFFSET1	[23:0]					OFFSET1[23:0]				0x800000	RW
0x32	OFFSET2	[23:0]					OFFSET2[23:0]				0x800000	RW
0x33	OFFSET3	[23:0]					OFFSET3[23:0]				0x800000	RW
0x34	OFFSET4	[23:0]					OFFSET4[23:0]				0x800000	RW
0x35	OFFSET5	[23:0]					OFFSET5[23:0]				0x800000	RW
0x36	OFFSET6	[23:0]					OFFSET6[23:0]				0x800000	RW
0x37	OFFSET7	[23:0]					OFFSET7[23:0]				0x800000	RW
0x38	GAIN0	[23:0]					GAIN0[23:0]				0x5XXXX0	RW
0x39	GAIN1	[23:0]					GAIN1[23:0]				0x5XXXX0	RW
0x3A	GAIN2	[23:0]					GAIN2[23:0]				0x5XXXX0	RW
0x3B	GAIN3	[23:0]					GAIN3[23:0]				0x5XXXX0	RW
0x3C	GAIN4	[23:0]					GAIN4[23:0]				0x5XXXX0	RW
0x3D	GAIN5	[23:0]					GAIN5[23:0]				0x5XXXX0	RW
0x3E	GAIN6	[23:0]					GAIN6[23:0]				0x5XXXX0	RW
0x3F	GAIN7	[23:0]					GAIN7[23:0]				0x5XXXX0	RW

REGISTER DETAILS

COMMUNICATIONS REGISTER

Address: 0x00, Reset: 0x00, Name: COMMS

All access to the on-chip registers must start with a write to the communications register. This write determines which register is accessed next and whether that operation is a write or a read.

Table 24. Bit Descriptions for COMMS

Bits	Bit Name	Settings	Description	Reset	Access
7	\overline{WEN}		This bit must be low to begin communications with the ADC	0x0	W
6	R/ \overline{W}	0 1	This bit determines if the command is a read or write operation Write command Read command	0x0	W
[5:0]	RA	000000 000001 000010 000011 000100 000110 000111 010000 010001 010010 010011 010100 010101 010110 010111 011000 011001 011010 011011 011100 011101 011110 011111 100000 100001 100010 100011 100100 100101 100110 100111 101000 101001 101010 101011 101100 101101 101110 101111	The register address bits determine the register to be read from or written to as part of the current communication Status register ADC mode register Interface mode register Register checksum register Data register GPIO configuration register ID register Channel 0 register Channel 1 register Channel 2 register Channel 3 register Channel 4 register Channel 5 register Channel 6 register Channel 7 register Channel 8 register Channel 9 register Channel 10 register Channel 11 register Channel 12 register Channel 13 register Channel 14 register Channel 15 register Setup Configuration 0 register Setup Configuration 1 register Setup Configuration 2 register Setup Configuration 3 register Setup Configuration 4 register Setup Configuration 5 register Setup Configuration 6 register Setup Configuration 7 register Filter Configuration 0 register Filter Configuration 1 register Filter Configuration 2 register Filter Configuration 3 register Filter Configuration 4 register Filter Configuration 5 register Filter Configuration 6 register Filter Configuration 7 register	0x00	W

Bits	Bit Name	Settings	Description	Reset	Access
		110000	Offset 0 register		
		110001	Offset 1 register		
		110010	Offset 2 register		
		110011	Offset 3 register		
		110100	Offset 4 register		
		110101	Offset 5 register		
		110110	Offset 6 register		
		110111	Offset 7 register		
		111000	Gain 0 register		
		111001	Gain 1 register		
		111010	Gain 2 register		
		111011	Gain 3 register		
		111100	Gain 4 register		
		111101	Gain 5 register		
		111110	Gain 6 register		
		111111	Gain 7 register		

STATUS REGISTER

Address: 0x00, Reset: 0x80, Name: Status

The status register is an 8-bit register that contains ADC and serial interface status information. The register can optionally be appended to the data register by setting the DATA_STAT bit in the interface mode register.

Table 25. Bit Descriptions for STATUS

Bits	Bit Name	Settings	Description	Reset	Access
7	RDY		The status of RDY is output to the DOUT/RDY pin when \overline{CS} is low and a register is not being read. This bit goes low when the ADC writes a new result to the data register. In ADC calibration modes, this bit goes low when the ADC writes the calibration result. RDY is brought high automatically by a read of the data register.	0x1	R
		0	New data result available.		
		1	Awaiting new data result.		
6	ADC_ERROR		By default, this bit indicates if an ADC overrange or underrange occurred. The ADC result is clamped to 0xFFFFF for overrange errors and 0x000000 for underrange errors. This bit is updated when the ADC result is written and is cleared at the next update after removing the overrange or underrange condition.	0x0	R
		0	No error.		
		1	Error.		
5	CRC_ERROR		This bit indicates if a CRC error occurred during a register write. For register reads, the host microcontroller determines if a CRC error occurred. This bit is cleared by a read of this register.	0x0	R
		0	No error.		
		1	CRC error.		
4	REG_ERROR		This bit indicates if the content of one of the internal registers changes from the value calculated when the register integrity check is activated. The check is activated by setting the REG_CHECK bit in the interface mode register. This bit is cleared by clearing the REG_CHECK bit.	0x0	R
		0	No error.		
		1	Error.		

Bits	Bit Name	Settings	Description	Reset	Access
[3:0]	Channel		These bits indicate which channel was active for the ADC conversion whose result is currently in the data register. This may be different from the channel currently being converted. The mapping is a direct map from the channel register. Therefore, Channel 0 results in 0x0 and Channel 15 results in 0xF.	0x0	R
		0000	Channel 0.		
		0001	Channel 1.		
		0010	Channel 2.		
		0011	Channel 3.		
		0100	Channel 4.		
		0101	Channel 5.		
		0110	Channel 6.		
		0111	Channel 7.		
		1000	Channel 8.		
		1001	Channel 9.		
		1010	Channel 10.		
		1011	Channel 11.		
		1100	Channel 12.		
		1101	Channel 13.		
		1110	Channel 14.		
		1111	Channel 15.		

ADC MODE REGISTER

Address: 0x01, Reset: 0x2000, Name: ADCMODE

The ADC mode register controls the operating mode of the ADC and the master clock selection. A write to the ADC mode register resets the filter and the RDY bits and starts a new conversion or calibration.

Table 26. Bit Descriptions for ADCMODE

Bits	Bit Name	Settings	Description	Reset	Access
15	REF_EN		Enables internal reference and outputs a buffered 2.5 V to the REFOUT pin.	0x0	RW
		0	Disabled.		
		1	Enabled.		
14	Reserved		This bit is reserved. Set this bit to 0.	0x0	RW
13	SING_CYC		This bit can be used when only a single channel is active to set the ADC to only output at the settled filter data rate.	0x1	RW
		0	Disabled.		
		1	Enabled.		
[12:11]	Reserved		These bits are reserved. Set these bits to 0.	0x0	R
[10:8]	Delay		These bits allow a programmable delay to be added after a channel switch to allow the settling of external circuitry before the ADC starts processing its input.	0x0	RW
		000	0 μ s.		
		001	32 μ s.		
		010	128 μ s.		
		011	320 μ s.		
		100	800 μ s.		
		101	1.6 ms.		
		110	4 ms.		
		111	8 ms.		
7	Reserved		This bit is reserved. Set this bit to 0.	0x0	R

Bits	Bit Name	Settings	Description	Reset	Access
[6:4]	Mode	000 Continuous conversion mode. 001 Single conversion mode. 010 Standby mode. 011 Power-down mode. 100 Internal offset calibration. 101 Internal gain calibration 110 System offset calibration. 111 System gain calibration.	These bits control the operating mode of the ADC. See the Operating Modes section for more information.	0x0	RW
[3:2]	CLOCKSEL	00 Internal oscillator. 01 Internal oscillator output on the XTAL2/CLKIO pin. 10 External clock input on the XTAL2/CLKIO pin. 11 External crystal on the XTAL1 pin and the XTAL2/CLKIO pin.	These bits select the ADC clock source. Selecting the internal oscillator also enables the internal oscillator.	0x0	RW
[1:0]	Reserved		These bits are reserved; set these bits to 0.	0x0	R

INTERFACE MODE REGISTER

Address: 0x02, Reset: 0x0000, Name: IFMODE

The interface mode register configures various serial interface options.

Table 27. Bit Descriptions for IFMODE

Bits	Bit Name	Settings	Description	Reset	Access
[15:13]	Reserved		These bits are reserved; set these bits to 0.	0x0	R
12	ALT_SYNC	0 Disabled. 1 Enabled.	This bit enables a different behavior of the SYNC pin to allow the use of SYNC as a control for conversions when cycling channels	0x0	RW
11	IOSTRENGTH	0 Disabled (default). 1 Enabled.	This bit controls the drive strength of the DOUT/RDY pin. Set this bit when reading from the serial interface at high speed with a low IOVDD supply and moderate capacitance.	0x0	RW
[10:9]	Reserved		These bits are reserved; set these bits to 0.	0x0	R
8	DOUT_RESET	0 Disabled. 1 Enabled.	See the DOUT_RESET section	0x0	RW
7	CONTREAD	0 Disabled. 1 Enabled.	This bit enables the continuous read mode of the ADC data register. The ADC must be configured in continuous conversion mode to use continuous read mode. For more details, see the Operating Modes section.	0x0	RW
6	DATA_STAT	0 Disabled. 1 Enabled.	This bit enables the status register to be appended to the data register when read so that channel and status information are transmitted with the data. This is the only way to be sure that the channel bits read from the status register correspond to the data in the data register.	0x0	RW

Bits	Bit Name	Settings	Description	Reset	Access
5	REG_CHECK	0 1	This bit enables a register integrity checker, which can be used to monitor any change in the value of the user registers. To use this feature, configure all other registers as desired with this bit cleared. Then, write to this register to set the REG_CHECK bit to 1. If the contents of any of the registers change, the REG_ERROR bit is set in the status register. To clear the error, set the REG_CHECK bit to 0. Neither the interface mode register nor the ADC data or status registers are included in the registers that are checked. If a register must have a new value written, this bit must first be cleared; otherwise, an error is flagged when the new register contents are written. 0 Disabled. 1 Enabled.	0x0	RW
4	Reserved		This bit is reserved. Set this bit to 0.	0x0	R
[3:2]	CRC_EN	00 01 10	These bits enable CRC protection of register reads/writes. CRC increases the number of bytes in a serial interface transfer by one. 00 Disabled 01 XOR checksum enabled for register read transactions; register writes still use CRC with these bits set. 10 CRC checksum enabled for read and write transactions.	0x00	RW
1	Reserved		This bit is reserved. Set this bit to 0.	0x0	R
0	WL16	0 1	This bit changes the ADC data register to 16 bits. The ADC is not reset by a write to the interface mode register; therefore, the ADC result is not rounded to the correct word length immediately after writing to these bits. The first new ADC result is correct. 0 24-bit data. 1 16-bit data.	0x0	RW

REGISTER CHECK

Address: 0x03, Reset: 0x000000, Name: REGCHECK

The register check register is a 24-bit checksum calculated by exclusively OR'ing the contents of the user registers. The REG_CHECK bit in the interface mode register must be set for this checksum to operate; otherwise, the register reads 0.

Table 28. Bit Descriptions for REGCHECK

Bits	Bit Name	Settings	Description	Reset	Access
[23:0]	REGISTER_CHECK		This register contains the 24-bit checksum of user registers when the REG_CHECK bit is set in the interface mode register.	0x000000	R

DATA REGISTER

Address: 0x04, Reset: 0x000000, Name: Data

The data register contains the ADC conversion result. The encoding is offset binary, or it can be changed to unipolar by the BI_UNIPOLARx bits in the setup configuration registers. Reading the data register brings the \overline{RDY} bit and the \overline{RDY} output high if it is low. The ADC result can be read multiple times. However, because the \overline{RDY} output is brought high, it is not possible to determine if another ADC result is imminent. After the command to read the ADC register is received, the ADC does not write a new result into the data register.

Table 29. Bit Descriptions for Data

Bits	Bit Name	Settings	Description	Reset	Access
[23:0]	Data		This register contains the ADC conversion result. If DATA_STAT is set in the interface mode register, the status register is appended to this register when read, making this a 32-bit register. If WL16 is set in the interface mode register, this register is reduced to 16 bits.	0x000000	R

GPIO CONFIGURATION REGISTER

Address: 0x06, Reset: 0x0800, Name: GPIOCON

The GPIO configuration register controls the general-purpose I/O pins of the ADC.

Table 30. Bit Descriptions for GPIOCON

Bits	Bit Name	Settings	Description	Reset	Access
[15:14]	Reserved		Reserved.	0x0	R
13	OP_EN0_1	0 1	GPO0/GPO1 output enable. This bit enables the GPO0 and GPO1 pins. The outputs are referenced between AVDD and AVSS. Disabled. Enabled.	0x0	R/W
12	OW_EN	0 1	This bit enables the use of open wire detection of voltage channels. Disabled. Enabled.	0x0	R/W
11	SYNC_EN	0 1	SYNC input enable. This bit enables the $\overline{\text{SYNC}}$ pin as a sync input. When set low, the $\overline{\text{SYNC}}$ pin holds the ADC and filter in reset until $\overline{\text{SYNC}}$ goes high. An alternative operation of the $\overline{\text{SYNC}}$ pin is available when the ALT_SYNC bit in the interface mode register is set. This mode works only when multiple channels are enabled. In such cases, a low on the $\overline{\text{SYNC}}$ pin does not immediately reset the filter/modulator. Instead, if the $\overline{\text{SYNC}}$ pin is low when the channel is due to be switched, the modulator and filter are prevented from starting a new conversion. Bringing $\overline{\text{SYNC}}$ high begins the next conversion. This alternative sync mode allows $\overline{\text{SYNC}}$ to be used while cycling through channels. Disabled. Enabled.	0x1	R/W
[10:9]	ERR_EN	00 01 10 11	Error pin mode. These bits enable the $\overline{\text{ERROR}}$ pin as an error input/output. Disabled. Enable error input (active low). $\overline{\text{ERROR}}$ is an error input. The (inverted) readback state is OR'ed with other error sources and is available in the ADC_ERROR bit in the status register. The ERROR pin state can also be read from the ERR_DAT bit in this register. Enable open-drain error output (active low). $\overline{\text{ERROR}}$ is an open-drain error output. The status register error bits are OR'ed, inverted, and mapped to the $\overline{\text{ERROR}}$ pin. $\overline{\text{ERROR}}$ pins of multiple devices can be wired together to a common pull-up resistor so that an error on any device can be observed. General-purpose output (active low). $\overline{\text{ERROR}}$ is a general-purpose output. The status of the pin is controlled by the ERR_DAT bit in this register. This output is referenced between IOVDD and DGND, as opposed to the AVDD1 and AVSS levels used by the GPIOx pins. The output has an active pull-up resistor in this case.	0x0	R/W
8	ERR_DAT	0 1	Error pin data. This bit determines the logic level at the $\overline{\text{ERROR}}$ pin if the pin is enabled as a general-purpose output. This bit reflects the readback status of the pin if the pin is enabled as an input. Logic 0. Logic 1.	0x0	R/W
7	GP_DATA1	0 1	GPO1 data. This bit is the write data for GPO1. GPO1 = 0. GPO1 = 1.	0x0	R/W
6	GP_DATA0	0 1	GPO0 data. This bit is the write data for GPO0. GPO0 = 0. GPO0 = 1.	0x0	R/W
[5:0]	Reserved		Reserved.	0x0	R

ID REGISTER**Address: 0x07, Reset: 0x30DX, Name: ID**

The ID register returns a 16-bit ID. For the AD4111, this value is 0x30DX.

Table 31. Bit Descriptions for ID

Bits	Bit Name	Settings	Description	Reset	Access
[15:0]	ID		Product ID. The ID register returns a 16-bit ID code that is specific to the ADC.	0x30DX	R

CHANNEL REGISTER 0**Address: 0x10, Reset: 0x8001, Name: CH0**

The channel registers are 16-bit registers that select the currently active channels, the selected inputs for each channel, and the setup to be used to configure the ADC for that channel.

Table 32. Bit Descriptions for CH0

Bits	Bit Name	Settings	Description	Reset	Access
15	CH_EN0	0 1	This bit enables Channel 0. If more than one channel is enabled, the ADC automatically sequences between them. Disabled. Enabled.	0x1	R/W
[14:12]	SETUP_SELO	000 001 010 011 100 101 110 111	These bits identify which of the eight setups is used to configure the ADC for this channel. A setup comprises a set of four registers: a setup configuration register, a filter configuration register, an offset register, and a gain register. All channels can use the same setup, in which case the same 3-bit value must be written to these bits on all active channels, or up to eight channels can be configured differently. Setup 0. Setup 1. Setup 2. Setup 3. Setup 4. Setup 5. Setup 6. Setup 7.	0x0	R/W
[11:10]	Reserved		Reserved.	0x0	R
[9:0]	INPUT0	000000001 0000010000 0000100000 0000110000 0001000011 0001010000 0001100010 0001110000 0010000101 0010010000 0010100100 0010110000 0011000111 0011010000 0011100110 0011110000 0110001011 0110101010 0111001001	These bits select which input pair is connected to the input of the ADC for this channel. VIN0, VIN1. VIN0, VINCOM. VIN1, VIN0. VIN1, VINCOM. VIN2, VIN3. VIN2, VINCOM. VIN3, VIN2. VIN3, VINCOM. VIN4, VIN5. VIN4, VINCOM. VIN5, VIN4. VIN5, VINCOM. VIN6, VIN7. VIN6, VINCOM. VIN7, VIN6. VIN7, VINCOM. IIN3+, IIN3-. IIN2+, IIN2-. IIN1+, IIN1-.	0x1	R/W

Bits	Bit Name	Settings	Description	Reset	Access
		0111101000 1000110010 1010110110	IIN0+, IIN0-. Temperature sensor. Reference.		

CHANNEL REGISTER 1 TO CHANNEL REGISTER 15

Address: 0x11 to Address 0x1F, Reset: 0x0001, Name: CH1 to CH7

The remaining 15 channel registers share the same layout as Channel Register 0.

Table 33. CH1 to CH15 Register Map

Reg.	Name	Bits	Bit 7	Bit 6	Bit 5	Bit 4	Bit 3	Bit 2	Bit 1	Bit 0	Reset	RW
0x11	CH1	[15:8]	CH_EN1	SETUP_SEL1		Reserved		INPUT1[9:8]		0x0001	RW	
		[7:0]	INPUT1[7:0]									
0x12	CH2	[15:8]	CH_EN2	SETUP_SEL2		Reserved		INPUT2[9:8]		0x0001	RW	
		[7:0]	INPUT2[7:0]									
0x13	CH3	[15:8]	CH_EN3	SETUP_SEL3		Reserved		INPUT3[9:8]		0x0001	RW	
		[7:0]	INPUT3[7:0]									
0x14	CH4	[15:8]	CH_EN4	SETUP_SEL4		Reserved		INPUT4[9:8]		0x0001	RW	
		[7:0]	INPUT4[7:0]									
0x15	CH5	[15:8]	CH_EN5	SETUP_SEL5		Reserved		INPUT5[9:8]		0x0001	RW	
		[7:0]	INPUT5[7:0]									
0x16	CH6	[15:8]	CH_EN6	SETUP_SEL6		Reserved		INPUT6[9:8]		0x0001	RW	
		[7:0]	INPUT6[7:0]									
0x17	CH7	[15:8]	CH_EN7	SETUP_SEL7		Reserved		INPUT7[9:8]		0x0001	RW	
		[7:0]	INPUT7[7:0]									
0x18	CH8	[15:8]	CH_EN8	SETUP_SEL8		Reserved		INPUT8[9:8]		0x0001	RW	
		[7:0]	INPUT8[7:0]									
0x19	CH9	[15:8]	CH_EN9	SETUP_SEL9		Reserved		INPUT9[9:8]		0x0001	RW	
		[7:0]	INPUT9[7:0]									
0x1A	CH10	[15:8]	CH_EN10	SETUP_SEL10		Reserved		INPUT10[9:8]		0x0001	RW	
		[7:0]	INPUT10[7:0]									
0x1B	CH11	[15:8]	CH_EN11	SETUP_SEL11		Reserved		INPUT11[9:8]		0x0001	RW	
		[7:0]	INPUT11[7:0]									
0x1C	CH12	[15:8]	CH_EN12	SETUP_SEL12		Reserved		INPUT12[9:8]		0x0001	RW	
		[7:0]	INPUT12[7:0]									
0x1D	CH13	[15:8]	CH_EN13	SETUP_SEL13		Reserved		INPUT13[9:8]		0x0001	RW	
		[7:0]	INPUT13[7:0]									
0x1E	CH14	[15:8]	CH_EN14	SETUP_SEL14		Reserved		INPUT14[9:8]		0x0001	RW	
		[7:0]	INPUT14[7:0]									
0x1F	CH15	[15:8]	CH_EN15	SETUP_SEL15		Reserved		INPUT15[9:8]		0x0001	RW	
		[7:0]	INPUT15[7:0]									

SETUP CONFIGURATION REGISTER 0**Address: 0x20, Reset: 0x1000 Name: SETUPCON0**

The setup configuration registers are 16-bit registers that configure the reference selection, input buffers, and output coding of the ADC.

Table 34. Bit Descriptions for SETUPCON0

Bits	Bit Name	Settings	Description	Reset	Access
[15:13]	Reserved		These bits are reserved; set these bits to 0.	0x0	R
12	BI_UNIPOLAR0	0 1	Bipolar/unipolar. This bit sets the output coding of the ADC for Setup 0. Unipolar coded output. Bipolar coded output.	0x1	R/W
11	REFBUF0+	0 1	REF+ buffer. This bit enables or disables the REF+ input buffer. Disabled. Enabled.	0x0	R/W
10	REFBUF0–	0 1	REF– buffer. This bit enables or disables the REF– input buffer. Disabled. Enabled.	0x0	R/W
[9:8]	INBUF0	00 01 10 11	Input buffer. This bit enables or disables input buffers. Disabled. Reserved. Reserved. Enabled.	0x0	R/W
7	Reserved		This bit is reserved. Set this bit to 0.	0x0	R
6	Reserved		This bit is reserved. Set this bit to 0.	0x0	R
[5:4]	REF_SEL0	00 10 11	These bits allow the user to select the reference source for ADC conversion on Setup 0. External reference – REF±. Internal 2.5 V reference, must be enabled via ADCMODE (see Table 26). AVDD – AVSS.	0x0	R/W
[3:0]	Reserved		These bits are reserved. Set these bits to 0.	0x0	R

SETUP CONFIGURATION REGISTER 1 TO SETUP CONFIGURATION REGISTER 7**Address: 0x21 to Address 0x27, Reset: 0x1000, Name: SETUPCON1 to SETUPCON7**

The remaining seven setup configuration registers share the same layout as Setup Configuration Register 0.

Table 35. SETUPCON1 to SETUPCON7 Register Map

Reg.	Name	Bits	Bit 7	Bit 6	Bit 5	Bit 4	Bit 3	Bit 2	Bit 1	Bit 0	Reset	RW
0x21	SETUPCON1	[15:8]	Reserved			BI_UNIPOLAR1	REFBUF1+	REFBUF1–	INBUF1	0x1000	RW	
		[7:0]	Reserved	Reserved		REF_SEL1	Reserved					
0x22	SETUPCON2	[15:8]	Reserved			BI_UNIPOLAR2	REFBUF2+	REFBUF2–	INBUF2	0x1000	RW	
		[7:0]	Reserved	Reserved		REF_SEL2	Reserved					
0x23	SETUPCON3	[15:8]	Reserved			BI_UNIPOLAR3	REFBUF3+	REFBUF3–	INBUF3	0x1000	RW	
		[7:0]	Reserved	Reserved		REF_SEL3	Reserved					
0x24	SETUPCON4	[15:8]	Reserved			BI_UNIPOLAR4	REFBUF4+	REFBUF4–	INBUF4	0x1000	RW	
		[7:0]	Reserved	Reserved		REF_SEL4	Reserved					
0x25	SETUPCON5	[15:8]	Reserved			BI_UNIPOLAR5	REFBUF5+	REFBUF5–	INBUF5	0x1000	RW	
		[7:0]	Reserved	Reserved		REF_SEL5	Reserved					
0x26	SETUPCON6	[15:8]	Reserved			BI_UNIPOLAR6	REFBUF6+	REFBUF6–	INBUF6	0x1000	RW	
		[7:0]	Reserved	Reserved		REF_SEL6	Reserved					
0x27	SETUPCON7	[15:8]	Reserved			BI_UNIPOLAR7	REFBUF7+	REFBUF7–	INBUF7	0x1000	RW	
		[7:0]	Reserved	Reserved		REF_SEL7	Reserved					

FILTER CONFIGURATION REGISTER 0**Address: 0x28, Reset: 0x0500, Name: FILTCON0**

The filter configuration registers are 16-bit registers that configure the ADC data rate and filter options. Writing to any of these registers resets any active ADC conversion and restarts converting at the first channel in the sequence.

Table 36. Bit Descriptions for FILTCON0

Bits	Bit Name	Settings	Description	Reset	Access
15	SINC3_MAP0		If this bit is set, the mapping of the filter register changes to directly program the decimation rate of the sinc3 filter for Setup 0. All other options are eliminated. This bit allows fine tuning of the output data rate and filter notch for rejection of specific frequencies. The data rate when on a single channel equals $f_{MOD}/(32 \times FILTCON0[14:0])$.	0x0	RW
[14:12]	Reserved		These bits are reserved; set these bits to 0.	0x0	R
11	ENHFILTENO	0 1	This bit enables various postfilters for enhanced 50 Hz/60 Hz rejection for Setup 0. The ORDER0 bits must be set to 00 to select the sinc5 + sinc1 filter for this function to work. 0 Disabled. 1 Enabled.	0x0	RW
[10:8]	ENHFILTO	010 011 101 110	These bits select between various postfilters for enhanced 50 Hz/60 Hz rejection for Setup 0. 010 27 SPS, 47 dB rejection, 36.7 ms settling 011 25 SPS, 62 dB rejection, 40 ms settling 101 20 SPS, 86 dB rejection, 50 ms settling 110 16.67 SPS, 92 dB rejection, 60 ms settling	0x5	RW
7	Reserved		This bit is reserved. Set this bit to 0.	0x0	R
[6:5]	ORDER0	00 11	These bits control the order of the digital filter that processes the modulator data for Setup 0. 00 Sinc5 + sinc1 (default). 11 Sinc3.	0x0	RW
[4:0]	ODR0	00000 00001 00010 00011 00100 00101 00110 00111 01000 01001 01010 01011 01100 01101 01110 01111 10000 10001 10010 10011 10100 10101 10110	These bits control the output data rate of the ADC and, therefore, the settling time and noise for Setup 0. Rates shown are for single channel enabled sinc5 + sinc 1 filter. See Table 6 to Table 9 for multiple channels enabled. 00000 31,250 SPS. 00001 31,250 SPS. 00010 31,250 SPS. 00011 31,250 SPS. 00100 31,250 SPS. 00101 31,250 SPS. 00110 15,625 SPS. 00111 10,417 SPS. 01000 5208.30 SPS. 01001 2597.4 SPS (2604.2 SPS for sinc3). 01010 1007 SPS (1008.1 SPS for sinc3). 01011 503.8 SPS. 01100 381 SPS (401 SPS for sinc3). 01101 200.3 SPS. 01110 100.2 SPS. 01111 59.52 SPS (59.98 SPS for sinc3). 10000 49.68 SPS (50 SPS for sinc3). 10001 20.01 SPS. 10010 16.63 SPS (16.67 SPS for sinc3). 10011 10 SPS. 10100 5 SPS. 10101 2.5 SPS. 10110 1.25 SPS.	0x0	RW

FILTER CONFIGURATION REGISTER 1 TO FILTER CONFIGURATION REGISTER 7

Address: 0x29 to Address 0x2F, Reset: 0x0500, Name: FILTCON1 to FILTCON7

The remaining seven filter configuration registers share the same layout as Filter Configuration Register 0.

Table 37. FILTCON1 to FILTCON7 Register Map

Reg.	Name	Bits	Bit 7	Bit 6	Bit 5	Bit 4	Bit 3	Bit 2	Bit 1	Bit 0	Reset	RW
0x29	FILTCON1	[15:8]	SINC3_MAP1	Reserved			ENHFILTEN1	ENHFILT1			0x0500	RW
		[7:0]	Reserved	ORDER1	ODR1							
0x2A	FILTCON2	[15:8]	SINC3_MAP2	Reserved			ENHFILTEN2	ENHFILT2			0x0500	RW
		[7:0]	Reserved	ORDER2	ODR2							
0x2B	FILTCON3	[15:8]	SINC3_MAP3	Reserved			ENHFILTEN3	ENHFILT3			0x0500	RW
		[7:0]	Reserved	ORDER3	ODR3							
0x2C	FILTCON4	[15:8]	SINC3_MAP4	Reserved			ENHFILTEN4	ENHFILT4			0x0500	RW
		[7:0]	Reserved	ORDER4	ODR4							
0x2D	FILTCON5	[15:8]	SINC3_MAP5	Reserved			ENHFILTEN5	ENHFILT5			0x0500	RW
		[7:0]	Reserved	ORDER5	ODR5							
0x2E	FILTCON6	[15:8]	SINC3_MAP6	Reserved			ENHFILTEN6	ENHFILT6			0x0500	RW
		[7:0]	Reserved	ORDER6	ODR6							
0x2F	FILTCON7	[15:8]	SINC3_MAP7	Reserved			ENHFILTEN7	ENHFILT7			0x0500	RW
		[7:0]	Reserved	ORDER7	ODR7							

OFFSET REGISTER 0

Address: 0x30, Reset: 0x800000, Name: OFFSET0

The offset (zero-scale) registers are 24-bit registers that can be used to compensate for any offset error in the ADC or in the system.

Table 38. Bit Descriptions for OFFSET0

Bits	Bit Name	Settings	Description	Reset	Access
[23:0]	OFFSET0		Offset calibration coefficient for Setup 0.	0x800000	RW

OFFSET REGISTER 1 TO OFFSET REGISTER 7

Address: 0x31 to Address 0x37, Reset: 0x800000, Name: OFFSET1 to OFFSET7

The remaining seven offset registers share the same layout as Offset Register 0.

Table 39. OFFSET1 to OFFSET7 Register Map

Reg.	Name	Bits	Bits[23:0]	Reset	RW
0x31	OFFSET1	[23:0]	OFFSET1[23:0]	0x800000	RW
0x32	OFFSET2	[23:0]	OFFSET2[23:0]	0x800000	RW
0x33	OFFSET3	[23:0]	OFFSET3[23:0]	0x800000	RW
0x34	OFFSET4	[23:0]	OFFSET4[23:0]	0x800000	RW
0x35	OFFSET5	[23:0]	OFFSET5[23:0]	0x800000	RW
0x36	OFFSET6	[23:0]	OFFSET6[23:0]	0x800000	RW
0x37	OFFSET7	[23:0]	OFFSET7[23:0]	0x800000	RW

GAIN REGISTER 0**Address: 0x38, Reset: 0x5XXXX0, Name: GAIN0**

The gain (full-scale) registers are 24-bit registers that can be used to compensate for any gain error in the ADC or in the system.

Table 40. Bit Descriptions for GAIN0

Bits	Bit Name	Settings	Description	Reset ¹	Access
[23:0]	GAIN0		Gain calibration coefficient for Setup 0.	0x5XXXX0	RW

¹ X means don't care.

GAIN REGISTER 1 TO GAIN REGISTER 7**Address: 0x39 to 0x3F, Reset: 0x5XXXX0, Name: GAIN1 to GAIN7**

The remaining seven gain registers share the same layout as Gain Register 0.

Table 41. GAIN1 to GAIN7 Register Map

Reg.	Name	Bits	Bits[23:0]	Reset ¹	RW
0x39	GAIN1	[23:0]	GAIN1[23:0]	0x5XXXX0	RW
0x3A	GAIN2	[23:0]	GAIN2[23:0]	0x5XXXX0	RW
0x3B	GAIN3	[23:0]	GAIN3[23:0]	0x5XXXX0	RW
0x3C	GAIN4	[23:0]	GAIN4[23:0]	0x5XXXX0	RW
0x3D	GAIN5	[23:0]	GAIN5[23:0]	0x5XXXX0	RW
0x3E	GAIN6	[23:0]	GAIN6[23:0]	0x5XXXX0	RW
0x3F	GAIN7	[23:0]	GAIN7[23:0]	0x5XXXX0	RW

¹ X means don't care.