

8-Channel, 12-Bit, Configurable ADC/DAC with On-Chip Reference, I²C Interface

FEATURES

- ▶ 8-channel, configurable ADC/DAC/GPIO
 - ▶ Configurable as any combination of
 - ▶ 8 12-bit DAC channels
 - ▶ 8 12-bit ADC channels
 - ▶ 8 general-purpose I/O pins
- ▶ Integrated temperature sensor
- ▶ 16-lead TSSOP and LFCSP and 16-ball WLCSP packages
- ▶ I²C interface

APPLICATIONS

- ▶ Control and monitoring
- ▶ General-purpose analog and digital I/O

GENERAL DESCRIPTION

The AD5593R has eight input/output (I/O) pins, which can be independently configured as digital-to-analog converter (DAC) outputs, analog-to-digital converter (ADC) inputs, digital outputs, or digital inputs. When an I/O pin is configured as an analog output, it is driven by a 12-bit DAC. The output range of the DAC is 0 V to V_{REF} or 0 V to $2 \times V_{REF}$. When an I/O pin is configured as an analog input, it is connected to a 12-bit ADC via an analog multiplexer. The input range of the ADC is 0 V to V_{REF} or 0 V to $2 \times V_{REF}$. The I/O pins can also be configured to be general-purpose, digital input or output (GPIO) pins. The state of the GPIO pins can be set or read back by accessing the GPIO write data register and GPIO read configuration registers, respectively, via an I²C write or read operation.

The AD5593R has an integrated 2.5 V, 20 ppm/°C reference that is turned off by default and an integrated temperature indicator that gives an indication of the die temperature. The temperature value is read back as part of an ADC read sequence.

The AD5593R is available in 16-lead TSSOP and LFCSP, as well as a 16-ball WLCSP, and operates over a temperature range of -40°C to +105°C.

Table 1. Related Products

Product	Description
AD5592R	AD5593R equivalent with SPI interface
AD5592R-1	AD5593R equivalent with SPI interface and V_{LOGIC} pin

FUNCTIONAL BLOCK DIAGRAM

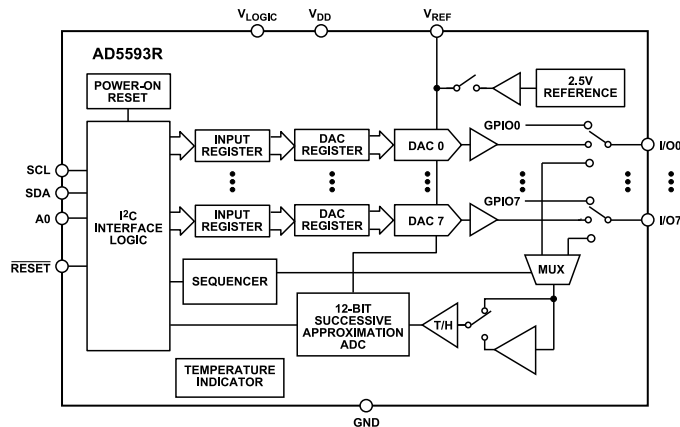

Figure 1.

TABLE OF CONTENTS

Features.....	1	DAC Write Operation.....	24
Applications.....	1	DAC Readback.....	24
General Description.....	1	ADC Operation	25
Functional Block Diagram.....	1	GPIO Operation.....	26
Specifications.....	3	Three-State Pins.....	26
Timing Characteristics.....	6	85 kΩ Pull-Down Pins.....	26
Absolute Maximum Ratings.....	7	Power-Down/Reference Control.....	26
Thermal Resistance.....	7	Reset Function.....	26
Electrostatic Discharge (ESD) Ratings.....	7	Applications Information.....	27
ESD Caution.....	7	Microprocessor Interfacing.....	27
Pin Configuration and Function Descriptions.....	8	AD5593R to ADSP-BF537 Interface.....	27
Typical Performance Characteristics.....	9	Layout Guidelines.....	27
Terminology.....	14	Register Map.....	28
Theory of Operation.....	17	Register Summary: AD5593R Pointer Byte Map	28
DAC Section.....	17	Register Summary (Bit-Wise): AD5593R Pointer Byte Map	28
ADC Section.....	18	Register Summary: AD5593R Control Register Map.....	28
GPIO Section.....	19	Register Details: AD5593R Pointer Byte Map..	29
Internal Reference.....	19	Register Details: AD5593R Control Register Map.....	31
Reset Function.....	19	Register Details: AD5593R ADC and DAC Readback	44
Temperature Indicator.....	19	Outline Dimensions.....	46
Serial Interface.....	20	Ordering Guide.....	47
Write Operation.....	20	Evaluation Boards.....	47
Read Operation.....	21		
Pointer Byte.....	22		
Control Registers.....	22		
General-Purpose Control Register.....	22		
Configuring the AD5593R.....	22		

REVISION HISTORY

8/2023—Rev. G to Rev. H

Changes to Table 3.....	6
Change to Figure 36.....	20
Changes to Figure 37 and Figure 38.....	21
Changes to Figure 39.....	22
Changes to Figure 41.....	24
Changes to Figure 42.....	25
Change to Reset Function Section.....	26
Changes to Table 8.....	28
Changes to Table 9.....	28

1/2023—Rev. F to Rev. G

Changes to Figure 42.....	25
---------------------------	----

SPECIFICATIONS

$V_{DD} = 2.7\text{ V to }5.5\text{ V}$, $V_{LOGIC} = 2.7\text{ V to }5.5\text{ V}$, $V_{REF} = 2.5\text{ V}$ (internal), Temperature Range $T_A = T_{MIN}$ to T_{MAX} , unless otherwise noted. Typical specs are verified by characterization, not production tested.

Table 2.

Parameter	Min	Typ	Max	Unit	Test Conditions/Comments
TEMPERATURE RANGE (T_A)					
Specified Performance	-40		+105	°C	
ADC PERFORMANCE					
Resolution		12		Bits	$f_{IN} = 10\text{ kHz sine wave}$
Input Range ¹	0		V_{REF}	V	ADC range select bit = 0
	0		$2 \times V_{REF}$	V	ADC range select bit = 1
Integral Nonlinearity (INL)	-2		+2	LSB	
Differential Nonlinearity (DNL)	-1		+1	LSB	
Offset Error			± 5	mV	
Gain Error			0.3	% FSR	
Track Time (t_{TRACK}) ²	500			ns	
Conversion Time (t_{CONV}) ²			2	μs	
Signal to Noise Ratio (SNR) ³		69		dB	$V_{DD} = 2.7\text{ V}$, input range = 0 V to V_{REF}
		67		dB	$V_{DD} = 5.5\text{ V}$, input range = 0 V to V_{REF}
		61		dB	$V_{DD} = 5.5\text{ V}$, input range = 0 V to $2 \times V_{REF}$
Signal-to-Noise + Distortion (SINAD) Ratio		69		dB	$V_{DD} = 2.7\text{ V}$, input range = 0 V to V_{REF}
		67		dB	$V_{DD} = 3.3\text{ V}$, input range = 0 V to V_{REF}
		60		dB	$V_{DD} = 5.5\text{ V}$, input range = 0 V to $2 \times V_{REF}$
Total Harmonic Distortion (THD)		-91		dB	$V_{DD} = 2.7\text{ V}$, input range = 0 V to V_{REF}
		-89		dB	$V_{DD} = 3.3\text{ V}$, input range = 0 V to V_{REF}
		-72		dB	$V_{DD} = 5.5\text{ V}$, input range = 0 V to $2 \times V_{REF}$
Spurious Free Dynamic Range (SFDR)		91		dB	$V_{DD} = 2.7\text{ V}$, input range = 0 V to V_{REF}
		91		dB	$V_{DD} = 3.3\text{ V}$, input range = 0 V to V_{REF}
		72		dB	$V_{DD} = 5.5\text{ V}$, input range = 0 V to $2 \times V_{REF}$
Aperture Delay ²		15		ns	$V_{DD} = 3\text{ V}$
		12		ns	$V_{DD} = 5\text{ V}$
Aperture Jitter ²		50		ps	
Channel-to-Channel Isolation		-95		dB	$f_{IN} = 5\text{ kHz}$
Full Power Bandwidth		8.2		MHz	At 3 dB
		1.6		MHz	At 0.1 dB
DAC PERFORMANCE⁴					
Resolution		12		Bits	
Output Range	0		V_{REF}	V	DAC range select bit = 0
	0		$2 \times V_{REF}$	V	DAC range select bit = 1
INL	-1		+1	LSB	
DNL	-1		+1	LSB	
Offset Error	-3		+3	mV	
Offset Error Drift ²		8		$\mu\text{V}/^\circ\text{C}$	
Gain Error			± 0.2	% FSR	Output range = 0 V to V_{REF}
			± 0.1	% FSR	Output range = 0 V to $2 \times V_{REF}$
Zero Code Error		0.65	2	mV	
Total Unadjusted Error (TUE)		± 0.03	± 0.25	% FSR	Output range = 0 V to V_{REF}
		± 0.015	± 0.1	% FSR	Output range = 0 V to $2 \times V_{REF}$
Capacitive Load Stability			2	nF	$R_{LOAD} = \infty$
			10	nF	$R_{LOAD} = 1\text{ k}\Omega$
Resistive Load	1			k Ω	

SPECIFICATIONS

Table 2. (Continued)

Parameter	Min	Typ	Max	Unit	Test Conditions/Comments
Short-Circuit Current		25		mA	
DC Crosstalk ²	-4		+4	μ V	Single channel, full-scale output change
DC Output Impedance		0.2		Ω	
DC Power Supply Rejection Ratio (PSRR) ²		0.15		mV/V	DAC code = midscale, $V_{DD} = 3\text{ V} \pm 10\%$ or $5\text{ V} \pm 10\%$
Load Impedance at Rails ⁵		25		Ω	
Load Regulation		200		μ V/mA	$V_{DD} = 5\text{ V} \pm 10\%$, DAC code = midscale, $-10\text{ mA} \leq I_{OUT} \leq +10\text{ mA}$
		200		μ V/mA	$V_{DD} = 3\text{ V} \pm 10\%$, DAC code = midscale, $-10\text{ mA} \leq I_{OUT} \leq +10\text{ mA}$
Power-Up Time		7		μ s	Exiting power-down mode, $V_{DD} = 5\text{ V}$
DAC AC SPECIFICATIONS					
Slew Rate		1.25		V/ μ s	
Settling Time		6		μ s	
DAC Glitch Impulse		2		nV-sec	
DAC to DAC Crosstalk		1		nV-sec	
Digital Crosstalk		0.1		nV-sec	
Analog Crosstalk		1		nV-sec	
Digital Feedthrough		0.1		nV-sec	
Multiplying Bandwidth		240		kHz	DAC code = full scale, output range = 0 V to $2 \times V_{REF}$
Output Voltage Noise Spectral Density		200		nV/ $\sqrt{\text{Hz}}$	DAC code = midscale, output range = 0 V to $2 \times V_{REF}$, measured at 10 kHz
SNR		81		dB	
SFDR		77		dB	
SINAD		74		dB	
Total Harmonic Distortion		-76		dB	
REFERENCE INPUT					
V_{REF} Input Voltage	1		V_{DD}	V	
DC Leakage Current	-1		+1	μ A	No I/Ox pins configured as DACs
V_{REF} Input Impedance		12		k Ω	DAC output range = 0 V to $2 \times V_{REF}$
		24		k Ω	DAC output range = 0 V to V_{REF}
REFERENCE OUTPUT					
V_{REF} Output Voltage	2.495	2.5	2.505	V	
V_{REF} Temperature Coefficient		20		ppm/ $^{\circ}\text{C}$	
Capacitive Load Stability		5		μ F	$R_{LOAD} = 2\text{ k}\Omega$
Output Impedance		0.15		Ω	$V_{DD} = 2.7\text{ V}$
		0.7		Ω	$V_{DD} = 5\text{ V}$
Output Voltage Noise		10		μ V p-p	0.1 Hz to 10 Hz
Output Voltage Noise Density		240		nV/ $\sqrt{\text{Hz}}$	At ambient, $f = 1\text{ kHz}$, $C_L = 10\text{ nF}$
Line Regulation		20		μ V/V	At ambient, sweeping V_{DD} from 2.7 V to 5.5 V
		10		μ V/V	At ambient, sweeping V_{DD} from 2.7 V to 3.3 V
Load Regulation					
Sourcing		210		μ V/mA	At ambient, $-5\text{ mA} \leq \text{load current} \leq +5\text{ mA}$
Sinking		120		μ V/mA	At ambient, $-5\text{ mA} \leq \text{load current} \leq +5\text{ mA}$
Output Current Load Capability		± 5		mA	$V_{DD} \geq 3\text{ V}$
GPIO OUTPUT					
I_{SOURCE} and I_{SINK}		1.6		mA	
Output Voltage					
High, V_{OH}	$V_{DD} - 0.2$			V	$I_{SOURCE} = 1\text{ mA}$
Low, V_{OL}			0.4	V	$I_{SINK} = 1\text{ mA}$
GPIO INPUT					
Input Voltage					

SPECIFICATIONS

Table 2. (Continued)

Parameter	Min	Typ	Max	Unit	Test Conditions/Comments
High, V_{IH}	$V_{DD} \times 0.7$			V	
Low, V_{IL}			$V_{DD} \times 0.3$	V	
Input Capacitance		20		pF	
Hysteresis		0.2		V	
Input Current		± 1		μA	
LOGIC INPUTS					
Input Voltage					
High, V_{INH}	$0.7 \times V_{LOGIC}$			V	
Low, V_{INL}			$0.3 \times V_{LOGIC}$	V	
Input Current, I_{IN}	-1	+0.01	+1	μA	
Input Capacitance, C_{IN}			10	pF	
LOGIC OUTPUT (SDA)					
Output High Voltage, V_{OH}	$V_{LOGIC} - 0.2$			V	$I_{SOURCE} = 200 \mu\text{A}$; $V_{LOGIC} = 2.7 \text{ V to } 5.5 \text{ V}$
Output Low Voltage, V_{OL}			0.4	V	$I_{SINK} = 200 \mu\text{A}$
Floating-State Output Capacitance		10		pF	
TEMPERATURE SENSOR ²					
Resolution		12		Bits	
Operating Range	-40		+105	$^{\circ}\text{C}$	
Accuracy		± 3		$^{\circ}\text{C}$	
Track Time			5	μs	ADC buffer enabled
			20	μs	ADC buffer disabled
POWER REQUIREMENTS					
V_{DD}	2.7		5.5	V	
I_{DD}					Digital inputs = 0 V or V_{LOGIC}
Power-Down Mode			3.5	μA	
Normal Mode					
$V_{DD} = 5 \text{ V}$		1.6		mA	I/O0 to I/O7 are DACs, internal reference, gain = 2
		1		mA	I/O0 to I/O7 are DACs, external reference, gain = 2
		2.4		mA	I/O0 to I/O7 are DACs and sampled by the ADC, internal reference, gain = 2
		1.1		mA	I/O0 to I/O7 are DACs and sampled by the ADC, external reference, gain = 2
		1		mA	I/O0 to I/O7 are ADCs, internal reference, gain = 2
		0.75		mA	I/O0 to I/O7 are ADCs, external reference, gain = 2
		0.5		mA	I/O0 to I/O7 are general-purpose outputs
		0.5		mA	I/O0 to I/O7 are general-purpose inputs
$V_{DD} = 3 \text{ V}$		1.1		mA	I/O0 to I/O7 are DACs, internal reference, gain = 1
		1		mA	I/O0 to I/O7 are DACs, external reference, gain = 1
		1.1		mA	I/O0 to I/O7 are DACs and sampled by the ADC, internal reference, gain = 1
		0.78		mA	I/O0 to I/O7 are DACs and sampled by the ADC, external reference, gain = 1
		0.75		mA	I/O0 to I/O7 are ADCs, internal reference, gain = 1
		0.5		mA	I/O0 to I/O7 are ADCs, external reference, gain = 1
		0.45		mA	I/O0 to I/O7 are general-purpose outputs
		0.45		mA	I/O0 to I/O7 are general-purpose inputs
V_{LOGIC}	1.8		V_{DD}	V	
I_{LOGIC}			3.5	μA	

SPECIFICATIONS

- ¹ When using the internal ADC buffer, there is a dead band of 0 V to 5 mV.
- ² Guaranteed by design and characterization; not production tested.
- ³ All specifications expressed in decibels are referred to full-scale input, FSR, and tested with an input signal at 0.5 dB below full scale, unless otherwise specified.
- ⁴ DC specifications tested with the outputs unloaded, unless otherwise noted. Linearity calculated using a reduced code range of 8 to 4085. An upper dead band of 10 mV exists when $V_{REF} = V_{DD}$.
- ⁵ When drawing a load current at either rail, the output voltage headroom with respect to that rail is limited by the 25 Ω typical channel resistance of the output devices. For example, when sinking 1 mA, the minimum output voltage = 25 Ω \times 1 mA = 25 mV (see Figure 26 and Figure 27).

TIMING CHARACTERISTICS

All input signals are specified with $t_R = t_F = 1$ ns/V (10% to 90% of V_{DD}) and timed from a voltage level of $(V_{IL} + V_{IH})/2$; $V_{DD} = 2.7$ V to 5.5 V, 1.8 V $\leq V_{LOGIC} \leq V_{DD}$; 2.5 V $\leq V_{REF} \leq V_{DD}$; all specifications T_{MIN} to T_{MAX} , unless otherwise noted.

Table 3.

Parameter ¹	Min	Typ	Max	Unit	Conditions/Comments
t_1	2.5			μ s	SCL cycle time
t_2	0.6			μ s	t_{HIGH} , SCL high time
t_3	1.3			μ s	t_{LOW} , SCL low time
t_4	0.6			μ s	$t_{HD,STA}$, start/repeated start condition hold time
t_5	100			ns	$t_{SU,DAT}$, data setup time
t_6^2			0.9	μ s	$t_{HD,DAT}$, data hold time
t_7	0.6			μ s	$t_{SU,STA}$, setup time for repeated start
t_8	0.6			μ s	$t_{SU,STO}$, stop condition setup time
t_9	1.3			μ s	t_{BUF} , bus free time between a stop and a start condition
t_{10}			300	ns	t_R , rise time of SCL and SDA when receiving
	0			ns	t_R , rise time of SCL and SDA when receiving (CMOS compatible)
t_{11}			250	ns	t_F , fall time of SDA when transmitting
	0			ns	t_F , fall time of SDA when receiving (CMOS compatible)
			300	ns	t_F , fall time of SCL and SDA when receiving
			300	ns	t_F , fall time of SCL and SDA when transmitting
t_{RESETL_PW}	250			ns	RESET low pulse width
C_B^3			400	pF	Capacitive load for each bus line

- ¹ Guaranteed by design and characterization; not production tested.
- ² A master device must provide a hold time of at least 300 ns for the SDA signal (referred to the V_{IH} min of the SCL signal) to bridge the undefined region of the falling edge of SCL.
- ³ C_B is the total capacitance of one bus line in pF. t_R and t_F are measured between 0.3 V_{LOGIC} and 0.7 V_{LOGIC} .

Timing Diagram

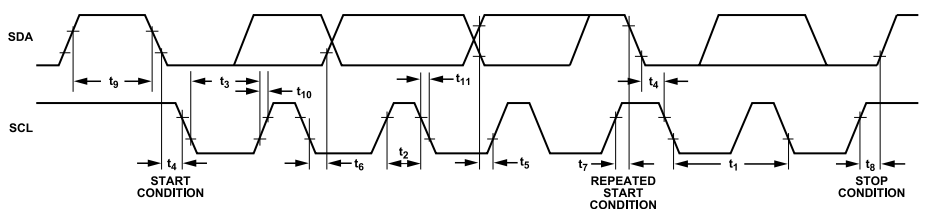

Figure 2. 2-Wire Serial Interface Timing Diagram

ABSOLUTE MAXIMUM RATINGS

$T_A = 25^\circ\text{C}$, unless otherwise noted. Transient currents of up to 100 mA do not cause SCR latch-up.

Table 4.

Parameter	Rating
V_{DD} to GND	-0.3 V to +7 V
V_{LOGIC} to GND	-0.3 V to +7 V
I/Ox to GND	-0.3 V to $V_{DD} + 0.3$ V
Digital Inputs to GND	-0.3 V to $V_{LOGIC} + 0.3$ V
Digital Outputs to GND	-0.3 V to $V_{LOGIC} + 0.3$ V
V_{REF} to GND	-0.3 V to $V_{DD} + 0.3$ V
Operating Temperature Range	-40°C to $+105^\circ\text{C}$
Storage Temperature Range	-65°C to $+150^\circ\text{C}$
Junction Temperature (T_J max)	$+150^\circ\text{C}$
Lead Temperature	JEDEC industry-standard
Soldering	J-STD-020

Stresses at or above those listed under Absolute Maximum Ratings may cause permanent damage to the product. This is a stress rating only; functional operation of the product at these or any other conditions above those indicated in the operational section of this specification is not implied. Operation beyond the maximum operating conditions for extended periods may affect product reliability.

THERMAL RESISTANCE

Thermal performance is directly linked to printed circuit board (PCB) design and operating environment. Careful attention to PCB thermal design is required.

Thermal characteristics are specified for the worst-case conditions, that is, a device soldered in a circuit board for surface-mount packages. Thermal resistance values specified in Table 5 are simulated based on JEDEC specifications using a 2S2P thermal test board (see JEDEC JESD51), except for θ_{JC-TOP} , which uses a JEDEC 1S test board.

θ_{JA} is the junction to ambient thermal resistance, measured in a JEDEC natural convection environment.

θ_{JC} is the junction to case thermal resistance, measured at the center of the package top surface, with an infinite heat sink attached to the package surface.

θ_{JB} is the junction to board thermal resistance, measured at a point on the board 1mm from the package edge, along the package centerline, measured in a JEDEC θ_{JB} environment.

Ψ_{JB} is the junction to board thermal characterization parameter, measured in a JEDEC natural convection environment.

Ψ_{JT} is the junction to package top thermal characterization parameter, measured in a JEDEC natural convection environment.

Do not use θ_{JA} , θ_{JC} , and θ_{JB} thermal resistances to perform direct calculation/measurement of the die temperature because doing so results in incorrect values. The thermal resistances assume 100% of the power that is dissipated along the specified path between the measurement points. The thermal resistances are directly dependent on the PCB design and environment.

If direct measurement of the package is required, the Ψ_{JT} and Ψ_{JB} values must be used because they more accurately reflect the true thermal dissipation paths.

θ_{JC} must only be used where an external heat sink is attached directly to the package.

System level thermal simulation is highly recommended.

For more details about the thermal resistances, refer to *JEDEC51-12: Guidelines for Reporting and Using Electronic Package Thermal Information*.

Table 5. Thermal Resistance

Package Type	θ_{JA}	θ_{JB}	θ_{JC-TOP}	Ψ_{JT}	Ψ_{JB}	Unit
CP-16-32	92.4	39.6	48.2	0.9	37.4	$^\circ\text{C}/\text{W}$
RU-16	127	60.2	42.2	2.6	59.1	$^\circ\text{C}/\text{W}$
CB-16-3	103.2	64	0	0	78	$^\circ\text{C}/\text{W}$

ELECTROSTATIC DISCHARGE (ESD) RATINGS

The following ESD information is provided for handling of ESD-sensitive devices in an ESD protected area only.

Human body model (HBM) per ANSI/ESDA/JEDEC JS-001.

Field induced charged device model (FICDM) and charged device model (CDM) per ANSI/ESDA/JEDEC JS-002.

ESD Ratings for AD5593R

Table 6. AD5593R, 16-Ball WLCSP, 16-Ball LFCSP, and 16-Lead TSSOP

ESD Model	Withstand Voltage (V)	Class
HBM	500	1B
FICDM	1250	C3

ESD CAUTION



ESD (electrostatic discharge) sensitive device. Charged devices and circuit boards can discharge without detection. Although this product features patented or proprietary protection circuitry, damage may occur on devices subjected to high energy ESD. Therefore, proper ESD precautions should be taken to avoid performance degradation or loss of functionality.

PIN CONFIGURATION AND FUNCTION DESCRIPTIONS

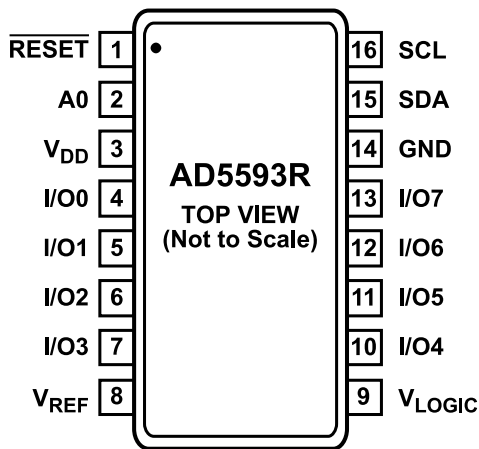

Figure 3. 16-Lead TSSOP Pin Configuration

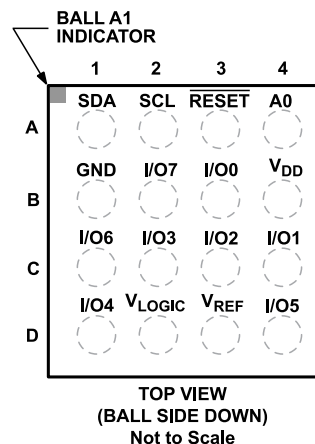

Figure 5. 16-Ball WLCSP Pin Configuration

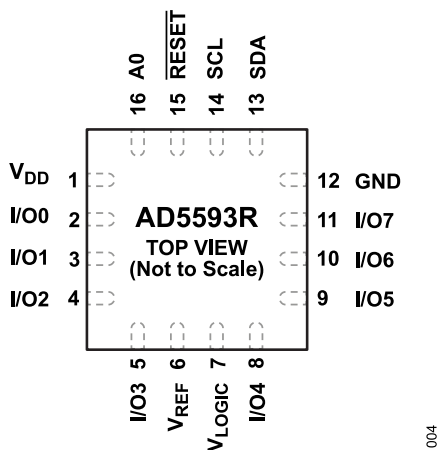

Figure 4. 16-Lead LFCSP Pin Configuration

Table 7. Pin Function Descriptions

Pin No.			Mnemonic	Description
TSSOP	LFCSP	WLCSP		
1	15	A3	RESET	Asynchronous Reset Pin. Tie this pin high for normal operation. When this pin is brought low, the AD5593R is reset to its default configuration.
2	16	A4	A0	Address Input. Sets the LSB of the 7-bit slave address.
3	1	B4	V _{DD}	Power Supply Input. The AD5593R can operate from 2.7 V to 5.5 V. Decouple the supply with a 0.1 μF capacitor to GND.
4 to 7, 10 to 13	2 to 5, 8 to 11	B3, C4, C3, C2, D1, D4, C1, B2	I/O0 to I/O7	Input/Output 0 Through Input/Output 7. These pins can be independently configured as DACs, ADCs, or general-purpose digital inputs or outputs. The function of each pin is determined by programming the appropriate bits in the configuration registers.
8	6	D3	V _{REF}	Reference Input/Output. When the internal reference is enabled, the 2.5 V reference voltage is available on the V _{REF} pin. A 0.1 μF capacitor connected from the V _{REF} pin to GND is recommended to achieve the specified performance from the AD5593R. When the internal reference is disabled, an external reference must be applied to this pin. The voltage range for the external reference is 1 V to V _{DD} .
9	7	D2	V _{LOGIC}	Interface Power Supply. The voltage on this pin ranges from 1.8 V to 5.5 V.
14	12	B1	GND	Ground Reference Point for All Circuitry.
15	13	A1	SDA	Serial Data Input. This pin is used with the SCL line to clock data in to or out of the input shift register. SDA is a bidirectional, open-drain line that must be pulled to the V _{LOGIC} supply with an external pull-up resistor.
16	14	A2	SCL	Serial Clock Line. This pin is used with the SDA line to clock data in to or out of the 16-bit input register.

TYPICAL PERFORMANCE CHARACTERISTICS

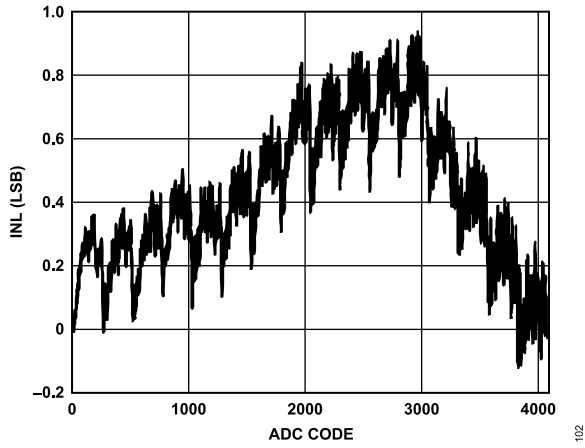

Figure 6. ADC INL; $V_{DD} = 5.5V$

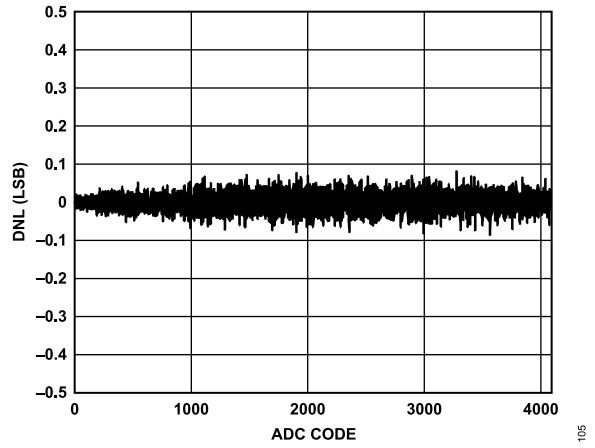

Figure 9. ADC DNL; $V_{DD} = 2.7V$

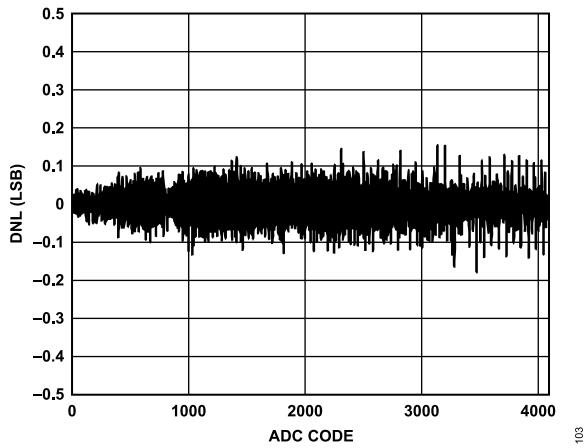

Figure 7. ADC DNL; $V_{DD} = 5.5V$

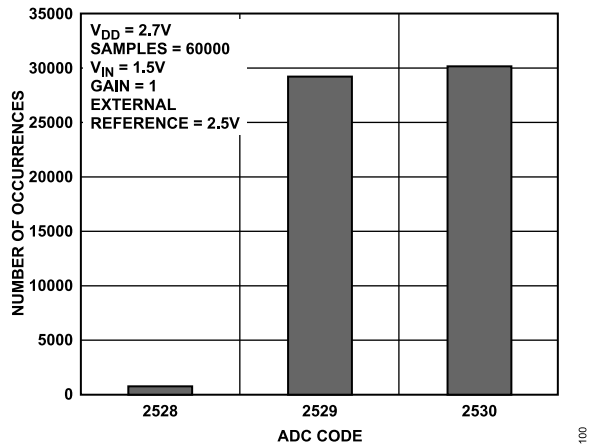

Figure 10. Histogram of ADC Codes; $V_{DD} = 2.7V$

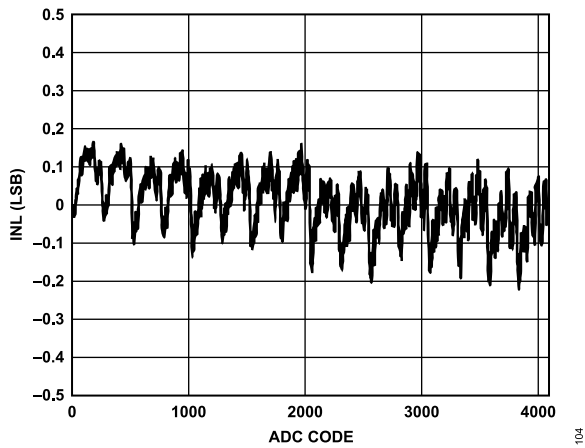

Figure 8. ADC INL; $V_{DD} = 2.7V$

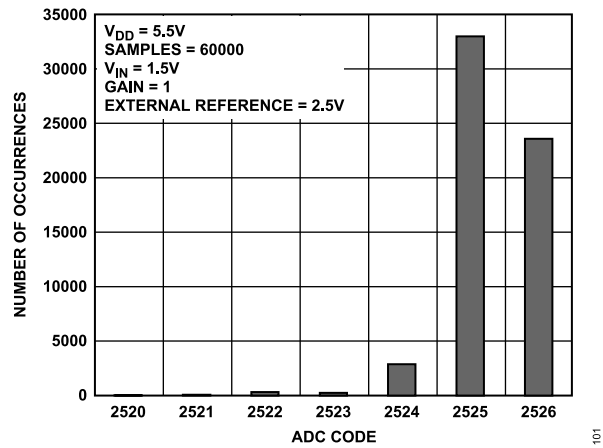

Figure 11. Histogram of Codes; $V_{DD} = 5.5V$

TYPICAL PERFORMANCE CHARACTERISTICS

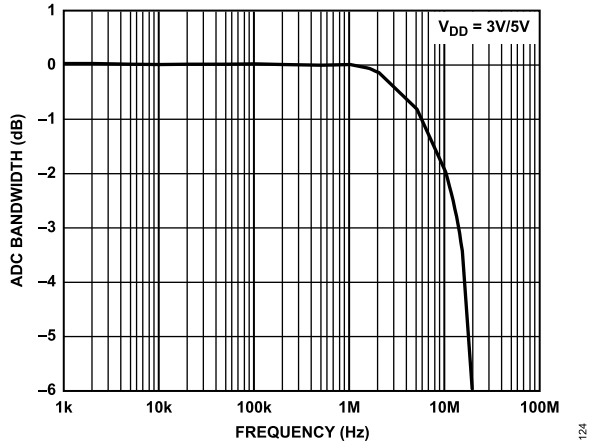

Figure 12. ADC Bandwidth

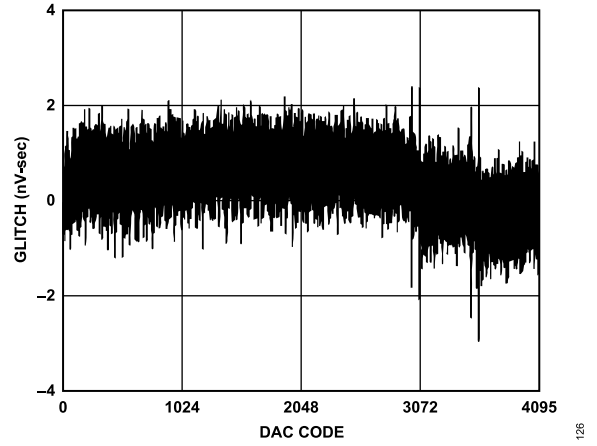

Figure 15. DAC Adjacent Code Glitch

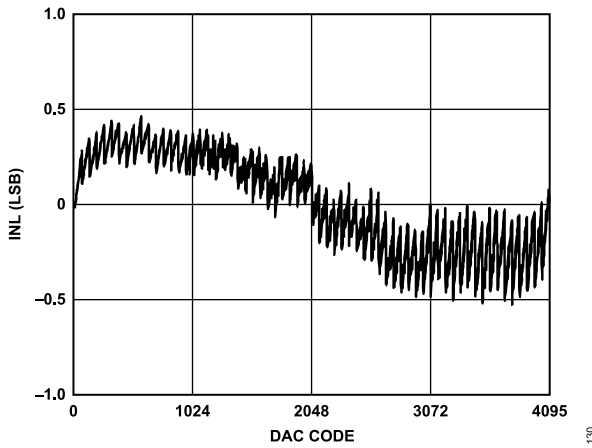

Figure 13. DAC INL

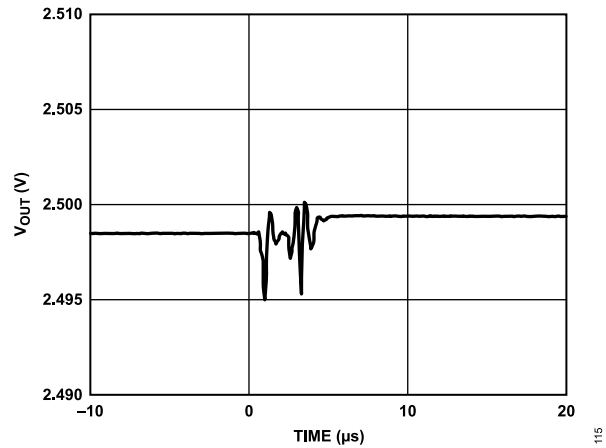

Figure 16. DAC Digital to Analog Glitch (Rising)

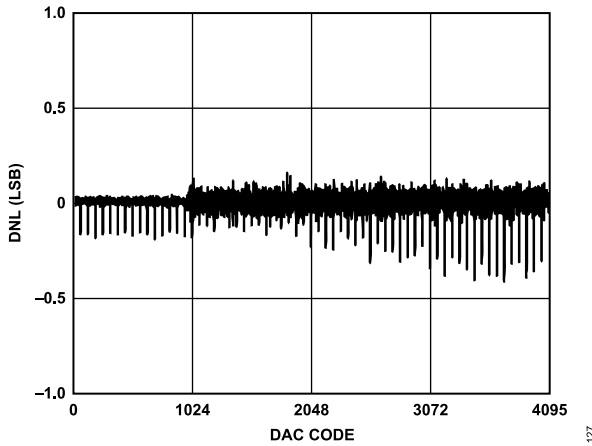

Figure 14. DAC DNL

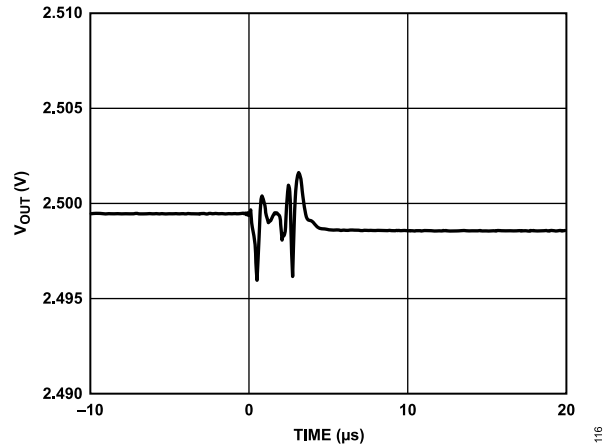

Figure 17. DAC Digital to Analog Glitch (Falling)

TYPICAL PERFORMANCE CHARACTERISTICS

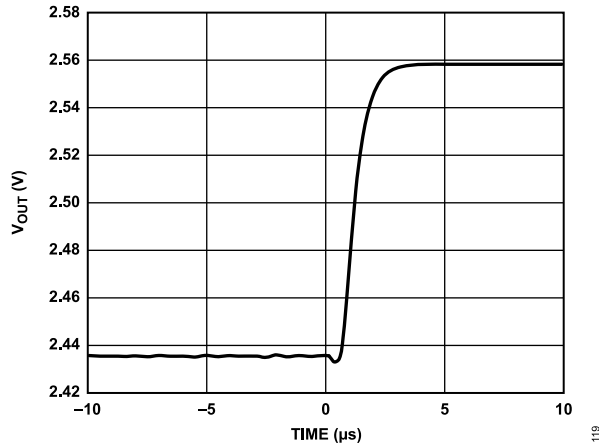

Figure 18. DAC Settling Time (100 Code Change, Rising Edge)

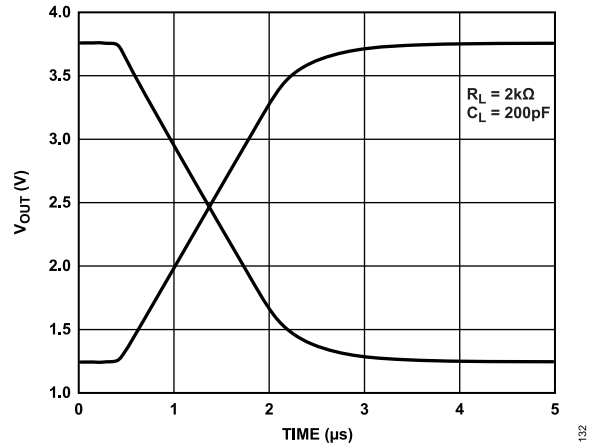

Figure 21. DAC Settling Time, Output Range = 0 V to $2 \times V_{REF}$

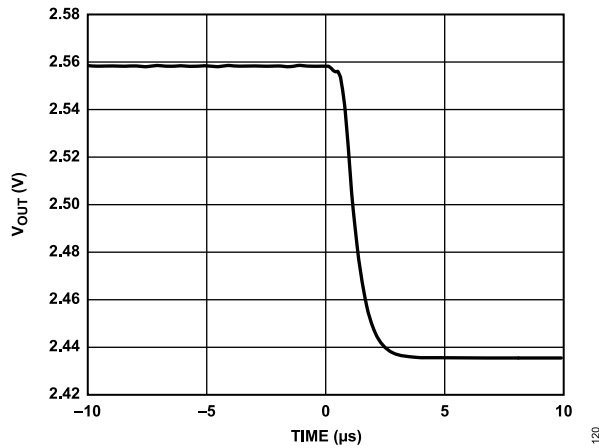

Figure 19. DAC Settling Time (100 Code Change, Falling Edge)

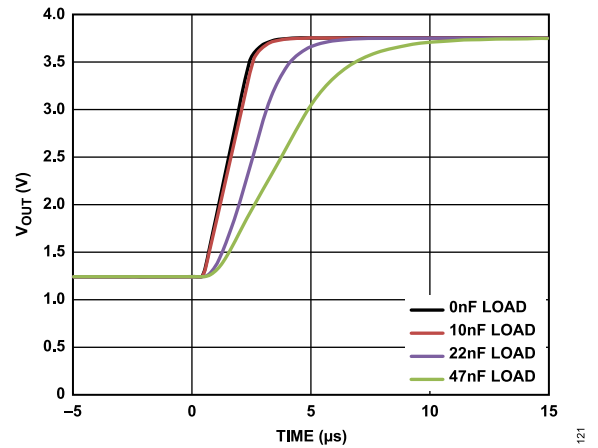

Figure 22. DAC Settling Time vs. Capacitive Load

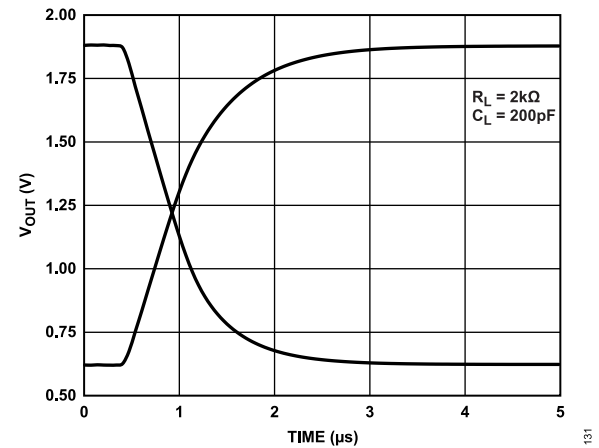

Figure 20. DAC Settling Time, Output Range = 0 V to V_{REF}

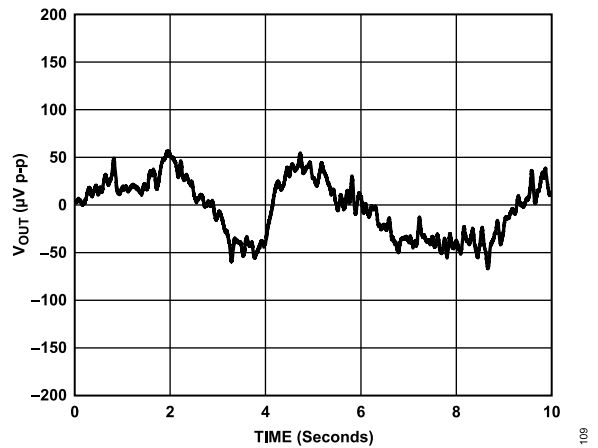

Figure 23. DAC 1/f Noise with External Reference

TYPICAL PERFORMANCE CHARACTERISTICS

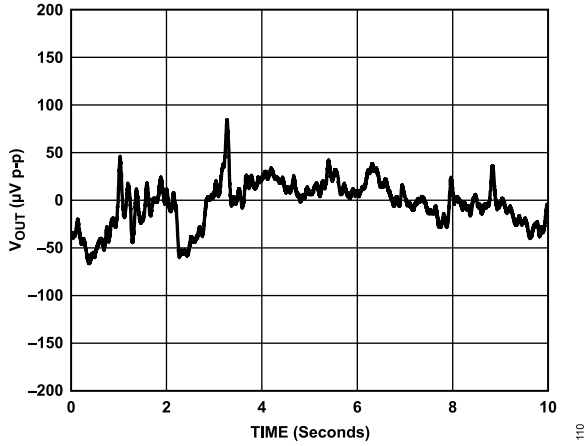

Figure 24. DAC 1/f Noise with Internal Reference

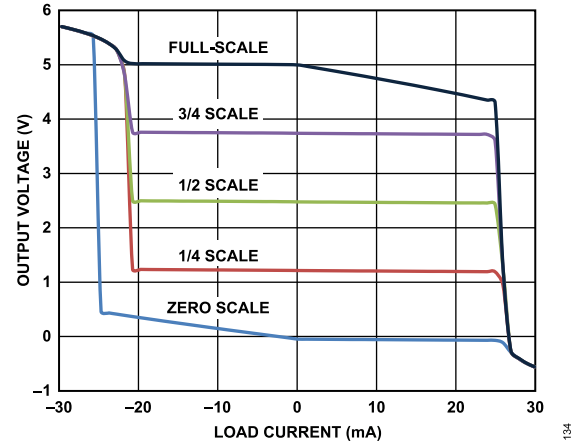

Figure 27. DAC Output Sink and Source Capability, Output Range = 0 V to 2 × V_{REF}

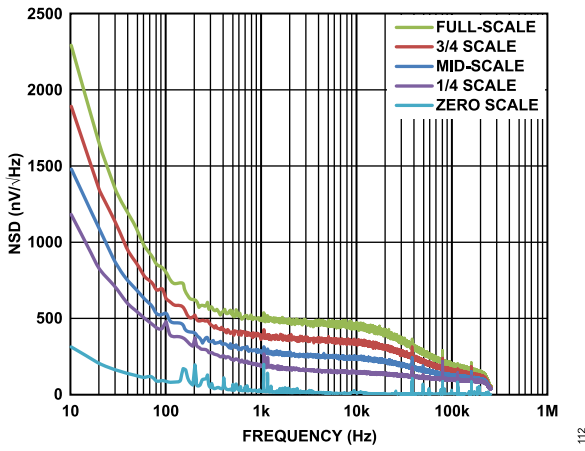

Figure 25. DAC Output Noise Spectral Density

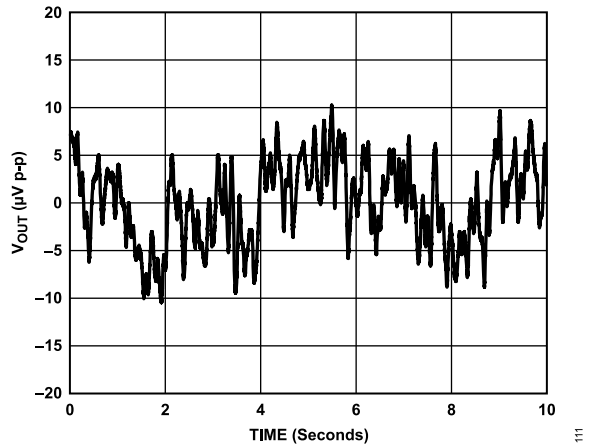

Figure 28. Internal Reference 1/f Noise

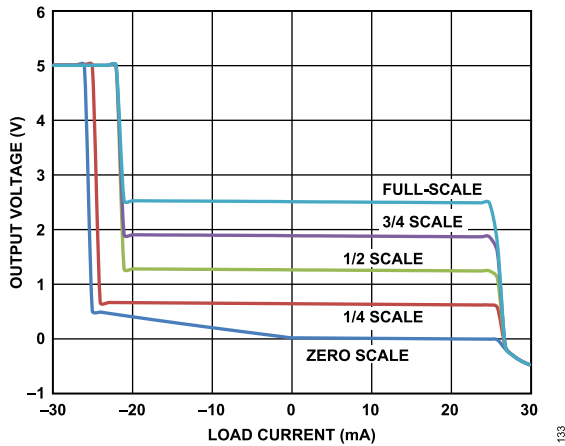

Figure 26. DAC Output Sink and Source Capability, Output Range = 0 V to V_{REF}

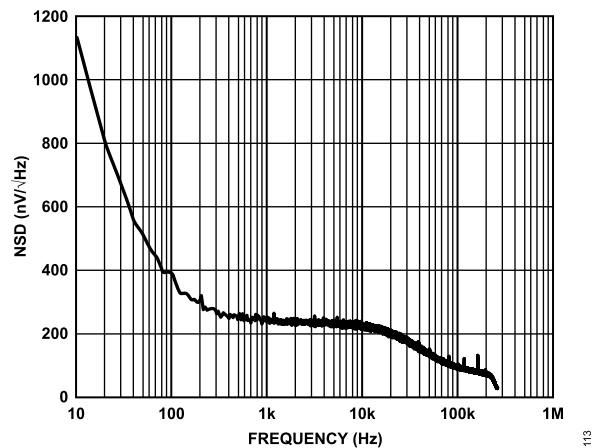

Figure 29. Reference Noise Spectral Density

TYPICAL PERFORMANCE CHARACTERISTICS

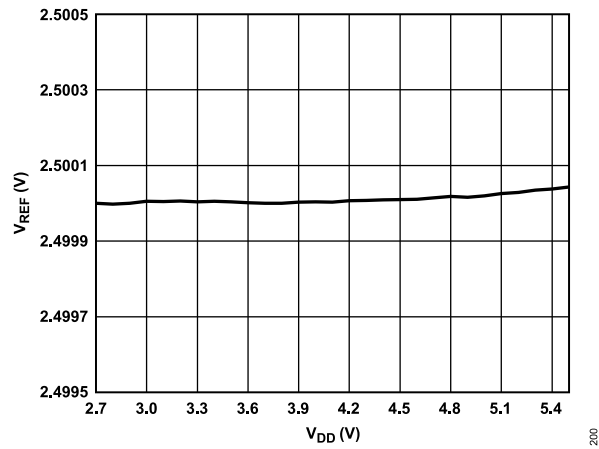

Figure 30. Reference Line Regulation

TERMINOLOGY

ADC Integral Nonlinearity (INL)

For the ADC, INL is the maximum deviation from a straight line passing through the endpoints of the ADC transfer function. The end points of the transfer function are zero scale, a point that is 1 LSB below the first code transition, and full scale, a point that is 1 LSB above the last code transition.

ADC Differential Nonlinearity (DNL)

For the ADC, DNL is the difference between the measured and the ideal 1 LSB change between any two adjacent codes in the ADC.

Offset Error

Offset error is the deviation of the first code transition (00 ... 000) to (00 ... 001) from the ideal, that is, AGND + 1 LSB.

Gain Error

Gain error is the deviation of the last code transition (111 ... 110) to (111 ... 111) from the ideal (that is, $V_{REF} - 1$ LSB) after the offset error has been adjusted out.

Channel-to-Channel Isolation

Channel-to-channel isolation is a measure of the level of crosstalk between channels. It is measured by applying a full-scale 5 kHz sine wave signal to all non-selected ADC input channels and determining how much that signal is attenuated in the selected channel. This specification is the worst case across all ADC channels for the AD5593R.

Track-and-Hold Acquisition Time

The track-and-hold amplifier goes into track mode when the ADC sequence register has been written to. The track and hold amplifier goes into hold mode when the conversion starts (see [Figure 39](#)). Track-and-hold acquisition time is the minimum time required for the track-and-hold amplifier to remain in track mode for its output to reach and settle to within ± 1 LSB of the applied input signal, given a step change to the input signal.

Signal-to-Noise Distortion Ratio SINAD

SINAD is the measured ratio of signal to (noise + distortion) at the output of the analog-to-digital converter. The signal is the rms amplitude of the fundamental. Noise is the sum of all non-fundamental signals up to half the sampling frequency ($f_S/2$), excluding dc. The ratio is dependent on the number of quantization levels in the digitization process; the more levels, the smaller the quantization noise. The theoretical SINAD for an ideal N-bit converter with a sine wave input is given by

$$\text{Signal-to-(Noise + Distortion) (dB)} = 6.02N + 1.76$$

Thus, for a 12-bit converter, this is 74 dB.

Total Harmonic Distortion (THD)

THD is the ratio of the rms sum of harmonics to the fundamental. For the AD5593R, it is defined as

$$THD \text{ (dB)} = 20 \times \log \frac{\sqrt{V_2^2 + V_3^2 + V_4^2 + V_5^2 + V_6^2}}{V_1} \quad (1)$$

where V_1 is the rms amplitude of the fundamental and V_2 , V_3 , V_4 , V_5 , and V_6 are the rms amplitudes of the second through the sixth harmonics.

Peak Harmonic or Spurious Noise

Peak harmonic or spurious noise is defined as the ratio of the rms value of the next largest component in the ADC output spectrum (up to $f_S/2$ and excluding dc) to the rms value of the fundamental. Normally, the value of this specification is determined by the largest harmonic in the spectrum, but for ADCs where the harmonics are buried in the noise floor, it is a noise peak.

DAC Relative Accuracy or Integral Nonlinearity (INL)

For the DAC, relative accuracy or integral nonlinearity is a measurement of the maximum deviation, in LSBs, from a straight line passing through the endpoints of the DAC transfer function. A typical INL vs. code plot is shown in [Figure 13](#).

DAC Differential Nonlinearity (DNL)

For the DAC, differential nonlinearity is the difference between the measured change and the ideal 1 LSB change between any two adjacent codes. A specified differential nonlinearity of ± 1 LSB maximum ensures monotonicity. This DAC is guaranteed monotonic by design. A typical DNL vs. code plot can be seen in [Figure 14](#).

Zero Code Error

Zero code error is a measurement of the output error when zero code (0x000) is loaded to the DAC register. Ideally, the output is 0 V. The zero code error is always positive in the AD5593R because the output of the DAC cannot go below 0 V due to a combination of the offset errors in the DAC and the output amplifier. Zero code error is expressed in mV.

Gain Error

Gain error is a measure of the span error of the DAC. It is the deviation in slope of the DAC transfer characteristic from the ideal expressed as % of FSR.

Offset Error

Offset error is a measure of the difference between V_{OUT} (actual) and V_{OUT} (ideal) expressed in mV in the linear region of the transfer function. Offset error can be negative or positive.

TERMINOLOGY

Offset Error Drift

Offset error drift is a measurement of the change in offset error with a change in temperature. It is expressed in $\mu\text{V}/^\circ\text{C}$.

DAC DC Power Supply Rejection Ratio (PSRR)

For the DAC, PSRR indicates how the output of the DAC is affected by changes in the supply voltage. PSRR is the ratio of the change in V_{OUT} to a change in V_{DD} for full-scale output of the DAC. It is measured in mV/V . V_{REF} is held at 2 V, and V_{DD} is varied by $\pm 10\%$.

Output Voltage Settling Time

Output voltage settling time is the amount of time it takes for the output of a DAC to settle to a specified level for a $\frac{1}{4}$ to $\frac{3}{4}$ full-scale input change and is measured from the rising edge of SDA that generates the stop condition.

Digital-to-Analog Glitch Impulse

Digital-to-analog glitch impulse is the impulse injected into the analog output when the input code in the DAC register changes state. It is normally specified as the area of the glitch in $\text{nV}\cdot\text{sec}$, and is measured when the digital input code is changed by 1 LSB at the major carry transition (0x7FF to 0x800) (see [Figure 16](#) and [Figure 17](#)).

Digital Feedthrough

Digital feedthrough is a measure of the impulse injected into the analog output of the DAC from the digital inputs of the DAC, but is measured when the DAC output is not updated. It is specified in $\text{nV}\cdot\text{sec}$, and measured with a full-scale code change on the data bus, that is, from all 0s to all 1s and vice versa.

Reference Feedthrough

Reference feedthrough is the ratio of the amplitude of the signal at the DAC output to the reference input when the DAC output is not being updated. It is expressed in dB.

Noise Spectral Density (NSD)

NSD is a measurement of the internally generated random noise. Random noise is characterized as a spectral density ($\text{nV}/\sqrt{\text{Hz}}$). It is measured by loading the DAC to midscale and measuring noise at the output. It is measured in $\text{nV}/\sqrt{\text{Hz}}$. A plot of noise spectral density is shown in [Figure 25](#).

DC Crosstalk

DC crosstalk is the dc change in the output level of one DAC in response to a change in the output of another DAC. It is measured with a full-scale output change on one DAC (or soft power-down and power-up) while monitoring another DAC kept at midscale. It is expressed in μV .

DC crosstalk due to load current change is a measure of the impact that a change in load current on one DAC has to another DAC kept at midscale. It is expressed in $\mu\text{V}/\text{mA}$.

Digital Crosstalk

Digital crosstalk is the glitch impulse transferred to the output of one DAC at midscale in response to a full-scale code change (all 0s to all 1s and vice versa) in the input register of another DAC. It is measured in standalone mode and is expressed in $\text{nV}\cdot\text{sec}$.

Analog Crosstalk

Analog crosstalk is the glitch impulse transferred to the output of one DAC due to a change in the output of another DAC. It is first measured by loading one of the input registers with a full-scale code change (all 0s to all 1s and vice versa). Then it is measured by executing software LDAC and monitoring the output of the DAC whose digital code was not changed. The area of the glitch is expressed in $\text{nV}\cdot\text{sec}$.

DAC-to-DAC Crosstalk

DAC-to-DAC crosstalk is the glitch impulse transferred to the output of one DAC due to a digital code change and subsequent analog output change of another DAC. It is measured by loading the attack channel with a full-scale code change (all 0s to all 1s and vice versa), using the write to and update commands while monitoring the output of the victim channel that is at midscale. The energy of the glitch is expressed in $\text{nV}\cdot\text{sec}$.

Multiplying Bandwidth

The amplifiers within the DAC have a finite bandwidth. The multiplying bandwidth is a measure of this finite bandwidth. A sine wave on the reference (with full-scale code loaded to the DAC) appears on the output. The multiplying bandwidth is the frequency at which the output amplitude falls to 3 dB below the input.

DAC Total Harmonic Distortion (THD)

For the DAC, THD is the difference between an ideal sine wave and its attenuated version using the DAC. The sine wave is used as the reference for the DAC, and the THD is a measurement of the harmonics present on the DAC output. It is measured in dB.

Voltage Reference Temperature Coefficient (TC)

Voltage reference TC is a measure of the change in the reference output voltage with a change in temperature. The voltage reference TC is calculated using the box method, which defines the TC as the maximum change in the reference output over a given temperature range expressed in $\text{ppm}/^\circ\text{C}$, as follows:

$$TC = \left[\frac{V_{REF(MAX)} - V_{REF(MIN)}}{V_{REF(NOM)} \times \text{Temp Range}} \right] \times 10^6 \quad (2)$$

where:

$V_{REF(MAX)}$ is the maximum reference output measured over the total temperature range.

$V_{REF(MIN)}$ is the minimum reference output measured over the total temperature range.

TERMINOLOGY

$V_{REF(NOM)}$ is the nominal reference output voltage, 2.5 V.

Temp Range is the specified temperature range of -40°C to $+105^{\circ}\text{C}$.

THEORY OF OPERATION

The AD5593R is an 8-channel, configurable analog and digital I/O port. The AD5593R has eight pins that can be independently configured as a 12-bit DAC output channel, a 12-bit ADC input channel, a digital input pin, or a digital output pin.

The function of each pin is determined by programming the ADC, DAC, or GPIO configuration registers as appropriate.

DAC SECTION

The AD5593R contains eight 12-bit DACs. Each DAC consists of a string of resistors followed by an output buffer amplifier. Figure 31 shows a block diagram of the DAC architecture.

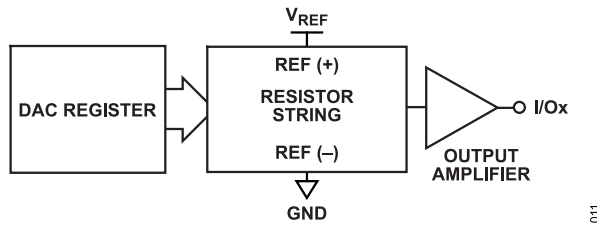

Figure 31. DAC Channel Architecture Block Diagram

The DAC channels share a single DAC range bit (in the [General-Purpose Control Register](#) section, see Bit 4 in [Table 19](#)) that sets the output range to 0 V to V_{REF} or 0 V to $2 \times V_{REF}$. Because the range bit is shared by all channels, it is not possible to set different output ranges on a per channel basis. The input coding to the DAC is straight binary. Therefore, the ideal output voltage is given by

$$V_{OUT} = G \times V_{REF} \times \left(\frac{D}{2^N}\right) \tag{3}$$

where:

$G = 1$ for an output range of 0 V to V_{REF} or $G = 2$ for an output range of 0 V to $2 \times V_{REF}$.

V_{REF} is the voltage on the V_{REF} pin.

D is the decimal equivalent of the binary code (0 to 4095) that is loaded to the DAC register.

$N = 12$.

Resistor String

The simplified segmented resistor string DAC structure is shown in [Figure 32](#). The code loaded to the DAC register determines the switch on the string that is connected to the output buffer.

Because each resistance in the string has the same value, R , the string DAC is guaranteed monotonic.

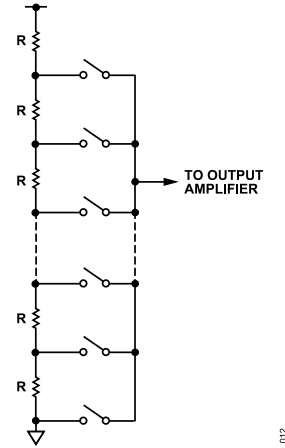

Figure 32. Resistor String

DAC Output Buffer

The output buffer is designed as an input/output rail-to-rail buffer. The output buffer can drive 2 nF capacitance with a 1 kΩ resistor in parallel. The slew rate is 1.25 V/μs with a ¼ to ¾ scale settling time of 6 μs. By default, the DAC outputs update directly after data has been written to the input register. The LDAC register delays the updates until additional channels have been written to if required. See the [LDAC Mode Operation](#) section for more information.

DAC Output Range

The DAC output voltage range can be configured to 0 V to V_{REF} (gain = 1) or 0 V to $2 \times V_{REF}$ (gain = 2) using DAC range bit of the general-purpose control register, as shown in [Figure 33](#) and [Figure 34](#), respectively. When $V_{REF} = V_{DD}$, the 0 V to $2 \times V_{REF}$ range does not allow the DAC to swing the output beyond V_{DD} .

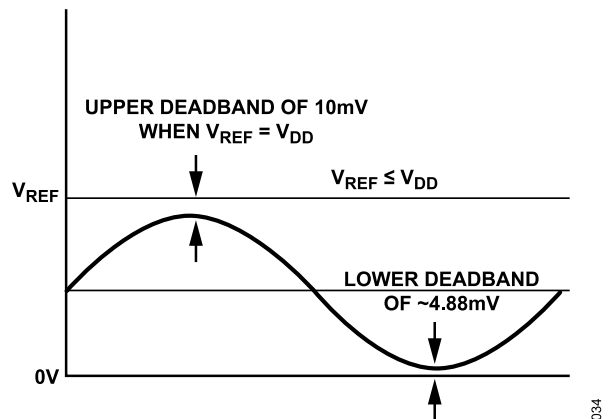

Figure 33. Output Voltage Range of the DAC with Gain = 1 (Unloaded Condition)

THEORY OF OPERATION

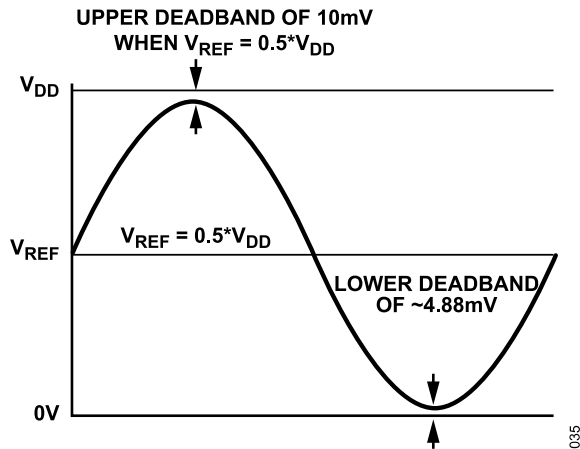

Figure 34. Output Voltage Range of the DAC with Gain = 2 (Unloaded Condition)

When $V_{REF} = V_{DD}$ for gain = 1 or $V_{REF} = 0.5 \times V_{DD}$ for gain = 2, there is an upper dead band of 10 mV at the DAC channel output in unloaded conditions. Additionally, there is a lower dead band of ~4.88 mV at the DAC channel output in unloaded conditions. When drawing a load current at either rail, the output voltage headroom with respect to that rail is limited by the 25 Ω typical channel resistance of the DAC channel. For example, when sinking 1 mA, the minimum output voltage = 25 $\Omega \times 1 \text{ mA} = 25 \text{ mV}$.

ADC SECTION

The ADC section is a fast, 12-bit, single-supply ADC with a conversion time of 2 μs . The ADC is preceded by a multiplexer that switches selected I/O pins to the ADC. A sequencer is included to switch the multiplexer to the next selected channel automatically. Channels are selected for conversion by writing to the ADC sequence register. When the write to the ADC sequence register has completed, the first channel in the conversion sequence is put into track mode. Each channel can track the input signal for a minimum of 500 ns. The conversion is initiated on the rising edge of the clock for the acknowledge (ACK) that occurs after the slave address (see Figure 39).

Each conversion takes 2 μs . The ADC has a range bit (ADC range select in the general-purpose control register, see Bit 5 in Table 19) that sets the input range as 0 V to V_{REF} or 0 V to $2 \times V_{REF}$. All input channels share the same range. The output coding of the ADC is straight binary. It is possible to set each I/Ox pin as both a DAC and an ADC. In this case, the primary function is that of the DAC. If the pin is selected for inclusion in an ADC conversion sequence, the voltage on the pin is converted and made available via the serial interface. This allows the DAC voltage to be monitored.

Calculating ADC Input Current

The current flowing into the I/Ox pins configured as ADC inputs varies with sampling rate (f_S), the voltage difference between successive channels (V_{DIFF}), and whether buffered or unbuffered mode is used. Figure 35 shows a simplified version of the ADC input structure. When a new channel is selected for conversion, 5.8 pF must be charged to or discharged from the voltage that on the previously selected channel. The time required for the charge or discharge depends on the voltage difference between the two channels. This dependence affects the input impedance of the multiplexer and, therefore, the input current flowing into the I/Ox pins.

In buffered mode, Switch S1 is open and Switch S2 is closed. In buffered mode, the U1 buffer directly drives the 23.1 pF capacitor and the charging time of the capacitors is negligible. In unbuffered mode, Switch S1 is closed and Switch S2 is closed. In unbuffered mode, the 23.1 pF capacitor must be charged from the I/Ox pins; this charging contributes to the input current. For applications where the ADC input current is too high, an external input buffer may be required. The choice of buffer is a function of the particular application.

Calculate the input current for buffered mode as follows:

$$f_S \times C \times V_{DIFF} + 1 \text{ nA}$$

where:

f_S is the ADC sample rate in Hz.

C is the sampling capacitance in farads.

V_{DIFF} is the voltage change between successive channels.

Calculate the input current for buffered mode as follows:

$$f_S \times C \times V_{DIFF}$$

where 1 nA is the dc leakage current associated with unbuffered mode.

The input current for the ADC in buffered mode, where I/O0 = 0.5 V, I/O1 = 2 V, and $f_S = 10 \text{ kHz}$, is as follows:

$$(10,000 \times 5.8 \times 10^{-12} \times 1.5) + 1 \text{ nA} = 88 \text{ nA}$$

Under the same conditions, the ADC input current in unbuffered mode is as follows:

$$(10,000 \times 28.9 \times 10^{-12} \times 1.5) = 433.5 \text{ nA}$$

THEORY OF OPERATION

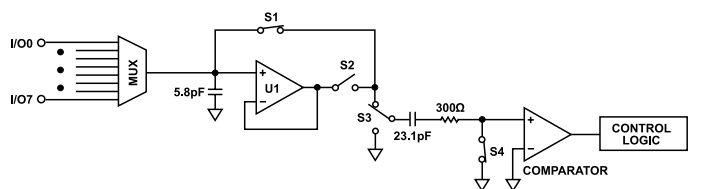

Figure 35. ADC Input Structure

GPIO SECTION

Each of the eight I/Ox pins can be configured as a general-purpose digital input by programming the GPIO read configuration register or output pin by programming the GPIO write configuration register. When an I/Ox pin is configured as an output, the pin can be set high or low by programming the GPIO write data register. Logic levels for general-purpose outputs are relative to V_{DD} and GND. When an I/Ox pin is configured as an input, its status can be determined by setting the pointer byte to 0b01100000. When an I/Ox pin is set as an output, it is possible to read its status by also setting it as an input pin. When reading the status of the I/Ox pins set as inputs the status of an I/Ox pin set as both an input and output pin is also returned.

INTERNAL REFERENCE

The AD5593R contains an on-chip 2.5 V reference. The reference is powered down by default and is enabled by setting Bit 9 in the power-down/reference control register to 1. When the on-chip reference is powered up, the reference voltage appears on the V_{REF} pin and may be used as a reference source for other components. When the internal reference is used, it is recommended to decouple V_{REF} to GND using a 100 nF capacitor. It is recommended that the internal reference be buffered before using it elsewhere in the system. When the reference is powered down, an external reference must be connected to V_{REF} . Suitable external reference sources for the AD5593R include the [AD780](#), [AD1582](#), [ADR431](#), [REF193](#), and [ADR391](#).

RESET FUNCTION

The AD5593R has an asynchronous $\overline{\text{RESET}}$ pin. For normal operation, $\overline{\text{RESET}}$ is tied high. A falling edge on $\overline{\text{RESET}}$ resets all registers to their default values and reconfigures the I/O pins to their default values (85 k Ω pull-down resistor to GND). The reset function takes 250 μs maximum; do not write new data to the

AD5593R during this time. The AD5593R has a software reset that performs the same function as the $\overline{\text{RESET}}$ pin. The reset function is activated by writing 0x0F to the pointer byte and 0x0D and 0xAC to the most significant and least significant bytes of the software reset register, respectively.

TEMPERATURE INDICATOR

The AD5593R contains an integrated temperature indicator that can be read to provide an estimation of the die temperature. This can be used in fault detection where a sudden rise in die temperature may indicate a fault condition, such as a shorted output. Temperature readback is enabled by setting Bit 8 in the ADC sequence register. The temperature result is then added to the ADC sequence. The temperature result has an address of 0b1000 (see [Table 34](#)) and care must be taken that this result is not confused with the readback from DAC0 (see [Table 32](#)). The temperature conversion takes 5 μs with the ADC buffer enabled and 20 μs when the buffer is disabled. Calculate the temperature using the following formulae:

For ADC gain = 1,

$$\text{Temperature } (^{\circ}\text{C}) = 25 + \frac{(\text{ADC Code} - (0.5 / V_{REF})) \times 4095}{(2.654 \times (2.5 / V_{REF}))}$$

For ADC gain = 2,

$$\text{Temperature } (^{\circ}\text{C}) = 25 + \frac{(\text{ADC Code} - (0.5 / (2 \times V_{REF})) \times 4095)}{(1.327 \times (2.5 / V_{REF}))}$$

The range of codes returned by the ADC when reading from the temperature indicator is approximately 645 to 1035, (for ADC gain = 1) corresponding to a temperature between -40°C and $+105^{\circ}\text{C}$. The accuracy of the temperature indicator is typically 3°C when averaged over five samples.

SERIAL INTERFACE

The AD5593R has a 2-wire, I²C-compatible serial interface (refer to *The I²C -Bus Specification*, Version 2.1, January 2000). The AD5593R is connected to an I²C bus as a slave device under the control of a master device. See Figure 2 for a timing diagram of a typical write sequence. The AD5593R supports standard mode (100 kHz) and fast mode (400 kHz). Support is not provided for 10-bit addressing and general call addressing. The AD5593R has a 7-bit slave address; its six MSBs are set to 001000. The LSB is set by the state of the A0 address pin, which determines the state of the A0 bit. The facility to change the logic level of the A0 pin before a read or write operation allows the user to incorporate multiple AD5593R devices on one bus.

The 2-wire serial bus protocol operates as follows: the master initiates data transfer by establishing a start condition when a high-to-low transition on the SDA line occurs while SCL is high. The following byte is the address byte, which consists of the 7-bit slave address. The slave address corresponding to the transmitted address responds by pulling SDA low during the ninth clock pulse (this is termed the acknowledge bit). At this stage, all other devices on the bus remain idle while the selected device waits for data to be written to or read from its shift register.

Data is transmitted over the serial bus in sequences of nine clock pulses (eight data bits followed by an acknowledge bit). The transi-

tions on the SDA line must occur during the low period of SCL and remain stable during the high period of SCL. When all data bits have been read or written, a stop condition is established.

In write mode, the master pulls the SDA line high during the 10th clock pulse to establish a stop condition. In read mode, the master issues a no acknowledge for the ninth clock pulse (that is, the SDA line remains high). The master brings the SDA line low before the 10th clock pulse and then high during the 10th clock pulse to establish a stop condition.

WRITE OPERATION

When writing to the AD5593R, the user must begin with a start command followed by an address byte ($R/\overline{W} = 0$), after which the AD5593R acknowledges that it is prepared to receive data by pulling SDA low. The AD5593R requires three bytes of data. The first byte is the pointer byte. This byte contains information defining the type of operation that is required of the AD5593R, such as configuring the I/O pins and writing to a DAC. The pointer byte is followed by the most significant byte and the least significant byte, as shown in Figure 36. After these data bytes are acknowledged by the AD5593R, a stop condition follows.

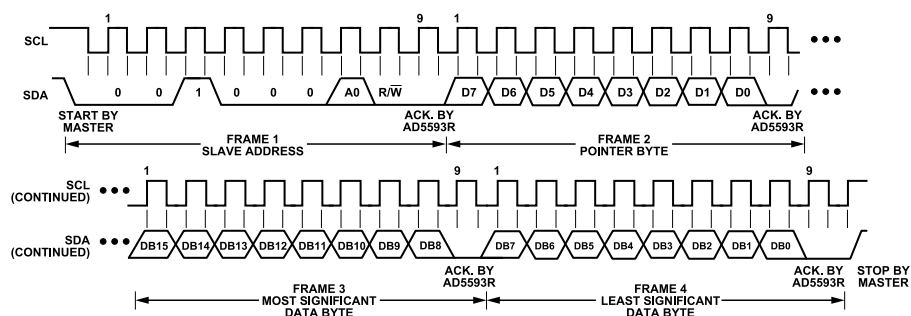

Figure 36. 4-Byte I²C Write

SERIAL INTERFACE

READ OPERATION

When reading data back from the AD5593R, the user begins with a start command followed by an address byte ($R/\bar{W} = 0$), after which the AD5593R acknowledges that it is prepared to transmit data by pulling SDA low. The pointer byte is then written to select what is to be read back. A repeat start or a new I²C transmission can then

follow to read two bytes of data from the AD5593R. Both bytes are acknowledged by the master, as shown in Figure 37.

It is also possible to perform consecutive readbacks without having to provide interim start and stop conditions or slave addresses. This method can be used to read blocks of conversions from the ADC, as shown in Figure 39.

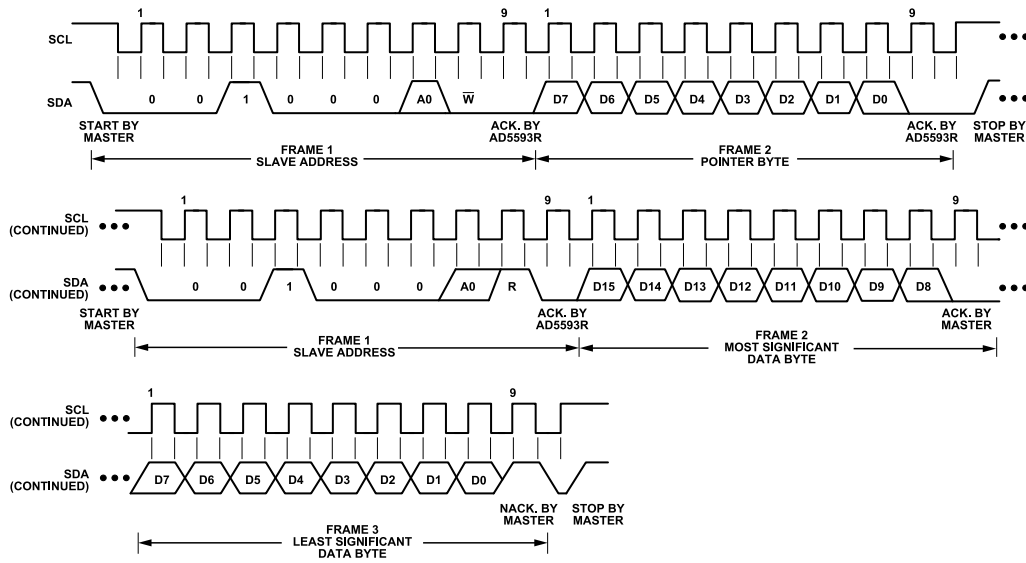

Figure 37. Read One 16-Bit Word

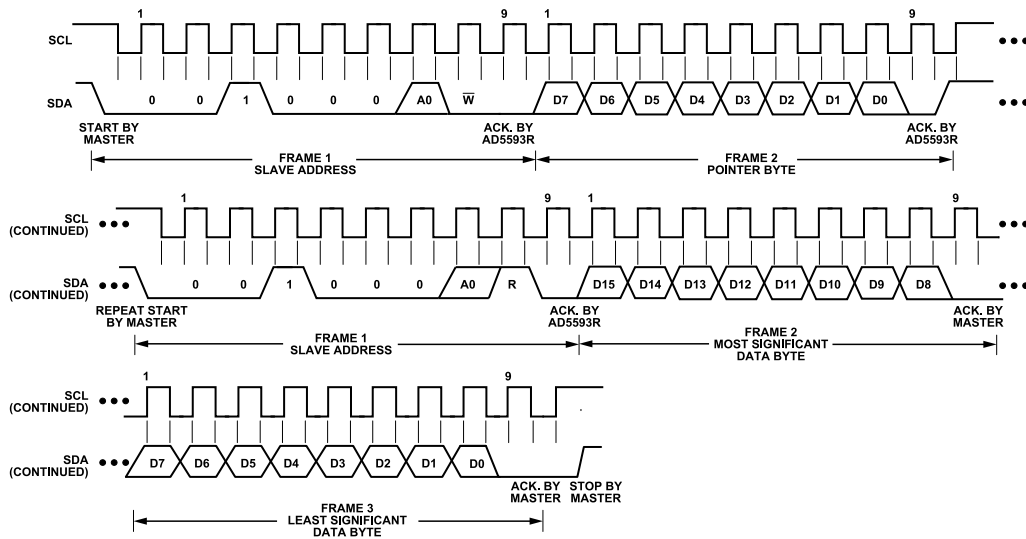
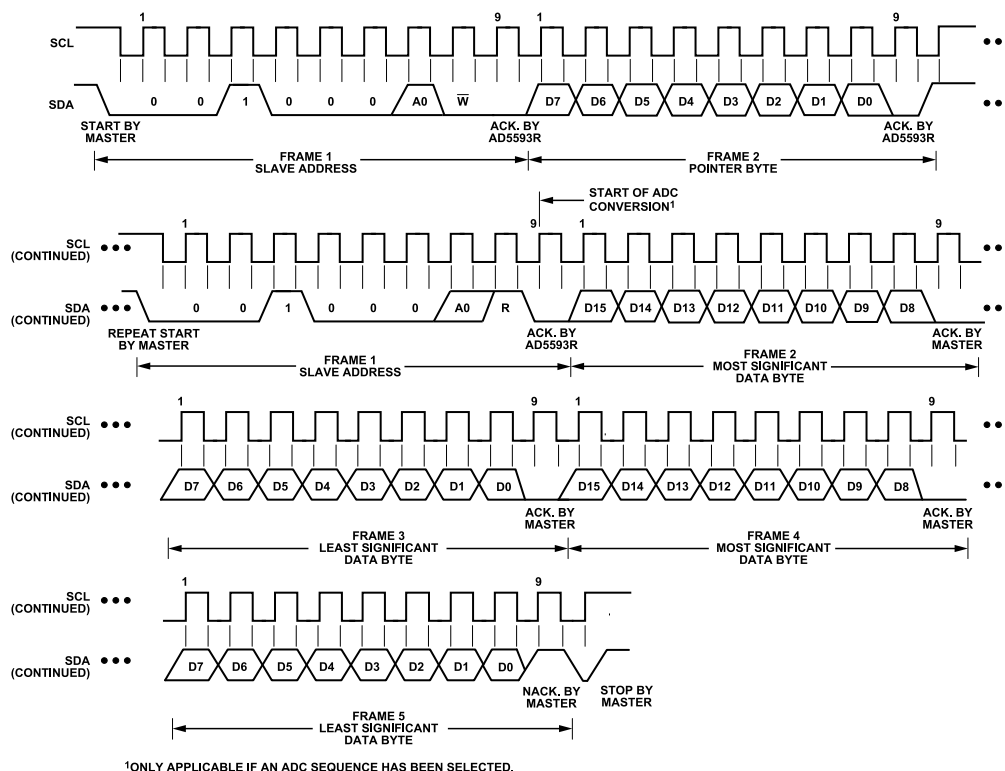

Figure 38. Read One 16-Bit Word, Maintain Control of the Bus

SERIAL INTERFACE

Figure 39. I²C Block Read

POINTER BYTE

The pointer byte contains eight bits. Bits[7:4] are mode bits that select the operation to be executed. The data contained in Bits[3:0] depend on the operation required. Table 8 and Table 9 show the configuration of the pointer byte. When Bits[7:4] are 0b0000, the mode dependent bits (Bits[3:0]) select a control register (see Table 10) to write data to. The data written to a control register is contained in the MSB and LSB as shown in Figure 36. The mode dependent data bits also select which DAC is updated during a DAC write operation and which register is selected for readback.

CONTROL REGISTERS

Table 11 shows the control register map for the AD5593R. The control registers configure the I/O pins and set various operating parameters in the AD5593R, such as enabling the reference, selecting the LDAC mode function, or selecting power-down modes. The control registers are written to using the 4-byte I²C write sequence shown in Figure 36. To write to a control register, the mode bits (Bits[7:4]) of the pointer byte are zeros. The mode dependent data bits (Bits[3:0]) of the pointer byte select which control register is to be accessed. The data to be written to the control register is contained in the most significant and least significant data bytes. These contain a total of 16 bits and are shown as Bits[15:0] in the Register Details: AD5593R Control Register Map section. The contents of the control registers can be read back using the read sequence shown in Figure 37 or Figure 38.

GENERAL-PURPOSE CONTROL REGISTER

The general-purpose control register enables or disables certain functions associated with the DAC, ADC, and I/O pin configuration (see Table 19). The register sets the output range of the DAC and input range of the ADC, which sets their transfer functions, enables/disables the ADC buffer, and enables the precharge function (see the ADC Section section for more details). The register is also used to lock the I/O pin configuration to prevent accidental change. When Bit 7 is set to 1, writes to the configuration registers are ignored.

CONFIGURING THE AD5593R

The AD5593R I/O pins are configured by writing to a series of pin configuration registers. The control registers are accessed when Bits[7:4] of the pointer byte are 0b0000. Bits[3:0] determine which register is accessed as shown in Table 11.

On power-up, the I/O pins are configured as 85 kΩ resistors connected to GND. The I/O channels of the AD5593R can be configured to operate as DAC outputs, ADC inputs, digital outputs, digital inputs, three-state, or connected to GND with 85 kΩ pull-down resistors. When configured as digital outputs, the pins have the additional option of being configured as push/pull or open-drain.

The I/O channels are configured by writing to the appropriate configuration registers, as shown in Table 11. To assign a particular function for an I/O channel, write to the appropriate register and

SERIAL INTERFACE

set the corresponding bit to 1. For example, setting Bit 0 in the DAC pin configuration register configures I/O0 as a DAC. In the event that the bit for an I/O channel is set in multiple configuration registers, the I/O channel adopts the function dictated by the last write operation.

The exceptions to this rule are that an I/Ox pin can be set as both a DAC and ADC or as a digital input and output. When an I/Ox pin is configured as a DAC and ADC, the primary function is as a DAC and the ADC can be used to measure the voltage being provided by the DAC. This feature can be used to monitor the output voltage to detect short circuits or overload conditions. Figure 40 shows an example of how to configure I/O1 and I/O7 as DACs. When a pin is configured as both a general-purpose input and output,

the primary function is as an output pin. This configuration allows the status of the output pin to be determined by programming the GPIO read configuration register and then setting the pointer byte to 0b01100000.

The general-purpose control register contains a lock configuration bit. When the lock configuration bit is set to 1, any writes to the pin configuration registers are ignored, thus preventing the function of the I/O pins from being changed.

The I/O pins can be reconfigured any time when the AD5593R is in an idle state, that is, no ADC conversions are taking place and no registers are being read back. The lock configuration bit must also be set to 0.

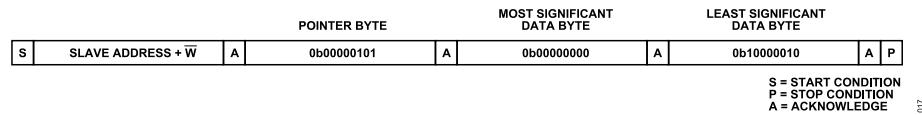

Figure 40. Configuring I/O1 and I/O7 as DACs

SERIAL INTERFACE

DAC WRITE OPERATION

Data is written to a DAC when the mode bits (Bits[7:4]) of the pointer byte are 0b0001 (see Table 8). Bits[2:0] determine which DAC is addressed (see Table 12). Data to be written to the DAC is contained in the MSB and LSB, as shown in Table 31. Data is written to the selected DAC input register. Data written to the input register can be automatically copied to the DAC register, if required. Data is transferred to the DAC register based on the setting of the LDAC mode register (see Table 23).

LDAC Mode Operation

The transfer of data from an input register to a DAC register is controlled by Bits[1:0] of the LDAC mode register (pointer byte = 0b00000111). When the LDAC mode bits (Bits[1:0]) are set to 00, new data is automatically transferred from the input register to the DAC register and the analog output updates. When the LDAC mode bits are set to 01, data remains in the input register. This allows writes to input registers without affecting the analog outputs. After loading the input registers with the desired values and setting

the LDAC mode bits to 10, the values in the input registers transfer to the DAC registers and the analog outputs update simultaneously. The LDAC mode bits then revert to 01.

DAC READBACK

The input register of each DAC can be read back via the I²C interface. This can be useful to confirm that the data was received correctly before writing to the LDAC mode register or simply checking what value was last loaded to a DAC. Data can be read back from a DAC only when no ADC conversion sequence is taking place. A DAC input register can be read back using the sequence shown in Figure 37 or Figure 38. The mode dependent bits, Bits[3:0], of the DAC readback mode register (pointer byte = 0b0101XXXX), select which DAC input register is to be read back (see Table 14). When the DAC register is read back as shown in Table 32, the MSB of the most significant data byte is a 1 to indicate that the result is a DAC register. The next three bits (Bits[14:12]) contain the DAC register address (see Table 32) and Bits[11:0] contain the DAC register value. Figure 41 shows an example of reading the input register of DAC2.

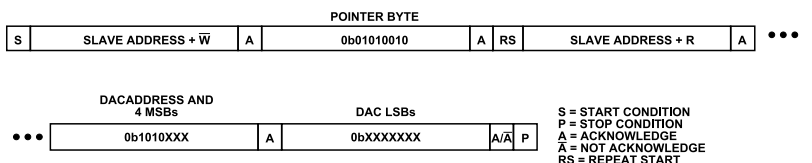

Figure 41. DAC Input Register Readback

SERIAL INTERFACE

ADC OPERATION

The ADC channels of the AD5593R operate as a traditional multi-channel ADC, where each serial transfer selects the next channel for conversion. The user must write to the ADC pin configuration register (see Table 20) to select the input channels as ADC inputs to be included in the conversion sequence before initiating any conversions. This is done using the I²C write sequence shown in Figure 36. When writing to the ADC sequence register (see Table 18), select which channels are to be converted in sequence. The user can also set the REP bit to have the ADC repeat conversions in the sequence.

When the sequence register has been written to, the ADC begins to track the first channel in the sequence. ADC data can be read from the AD5593R using any of the three read operations shown in Figure 37, Figure 38, and Figure 39, with the I²C block read (Figure 39) being the most efficient.

If more than one channel is selected in the ADC sequence register, the ADC converts all selected channels sequentially in ascending order. Conversion is started by the rising edge of SCL at the acknowledge (ACK) preceding the MSB (see Figure 39).

If the REP bit is set after all of the selected channels in the sequence register have been converted, the ADC repeats the

sequence. If the REP bit is clear, the ADC clocks out the last result on subsequent I²C reads. When ADC data is clocked out by the serial interface, Bit 15 = 0 to indicate that the result is ADC data. Bits[14:12] contain a 3-bit address to indicate which ADC the data is coming from, and Bits[11:0] contain the 12-bit ADC result (see Table 33).

Figure 42 shows how to configure the AD5593R to perform ADC conversions. In Step 1, I/O7 and I/O0 are configured as ADCs. Step 2 writes to the ADC sequence register, sets the REP bit, and selects ADC7 and ADC0 for inclusion in the conversion sequence. Step 3 selects the ADCs for reading and Step 4 begins reading the ADC results (see Table 33). The conversions are repeated until a stop condition is given by the controller.

The ADC sequence can be changed by writing the new sequence to the ADC sequence register when conversions are not taking place. When a new sequence is written, any channels remaining to be converted from the earlier sequence are ignored and the ADC starts converting the first channel of the new sequence.

To stop the ADC conversion sequence, clear the REP, TEMP, and ADC7 to ADC0 bits in the ADC sequence register to 0.

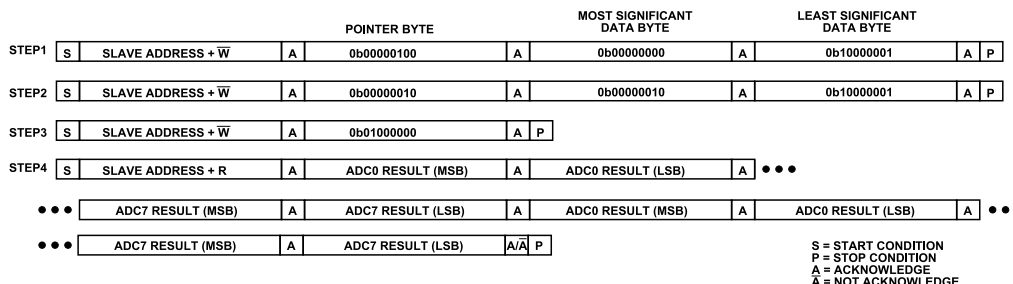

Figure 42. Configuring the ADC for Conversion

SERIAL INTERFACE

GPIO OPERATION

Each of the I/Ox pins of the AD5593R can be configured to operate as a general-purpose, digital input or output pin. The function of the pins is determined by writing to the appropriate bit in the GPIO read configuration register and the GPIO write configuration register using the 4-byte I²C write shown in [Figure 36](#).

Setting Pins as Outputs

To set a pin as a general-purpose output, set the appropriate bit in the GPIO write configuration register (pointer byte = 0b00001000) to 1. For example, setting Bit 0 to 1 enables I/O0 as a general-purpose output.

The outputs can be independently configured as push/pull or open-drain outputs. When in push/pull configuration, the output is driven to V_{DD} or GND as determined by the data in the GPIO write data register (pointer byte = 0b00001001). When in open-drain configuration (pointer byte = 0b00001100), the output is driven to GND when a data bit in the GPIO write data register sets the pin low. When the pin is set high, the output is not driven and must be pulled high by an external resistor. This allows multiple output pins to be tied together. If all the pins are normally high, it allows one pin to pull down the others. This is commonly used where multiple pins are used to trigger an alarm or interrupt pin. The state of the output pin is controlled by setting or clearing the bits in the GPIO write data register (pointer byte = 0b00001001). A data bit is ignored if it is written to a location that is not configured as an output.

Setting Pins as Inputs

To set an I/Ox pin as a general-purpose input, set the appropriate bit in the GPIO read configuration register (pointer byte = 0b00001010) to 1. For example, setting Bit 0 to 1 enables I/O0 as a general-purpose input. To read the state of general-purpose inputs, set the pointer byte to 0b01100000 (see [Table 9](#)) using any of the read operations shown in [Figure 37](#), [Figure 38](#), and [Figure 39](#). The status of any I/O pin set as a general-purpose input appears in the appropriate bit location in the least significant data byte.

THREE-STATE PINS

The I/Ox pins can be set to three-state by writing to the three-state configuration register (pointer byte = 0b00001101) as shown in [Table 29](#).

85 KΩ PULL-DOWN PINS

The I/Ox pins can be connected to GND via a pull-down resistor (85 kΩ) by setting the appropriate bits in the pull-down configuration register (pointer byte = 0b00000110) as shown in [Table 22](#).

POWER-DOWN/REFERENCE CONTROL

The AD5593R has a power-down/reference control register (pointer byte = 0b00001011) that reduces the power consumption when certain functions are not needed. The power-down register allows any channels set as DACs to be placed in a power-down state individually. When in power-down, the DAC outputs are three-stated. When a DAC channel is returned into normal mode, the DAC output returns to its previous value. The internal reference and its buffer are powered down by default and are enabled by setting the EN_REF bit in the power-down/reference control register. The internal reference voltage then appears at the V_{REF} pin.

There is no dedicated power-down function for the ADC, but the ADC is automatically powered down if none of the I/Ox pins are selected as ADCs. The ADC powers up if a read of the temperature indicator is initiated. The PD_ALL bit powers down all the DACs, the reference, its buffer, and the ADC. The PD_ALL bit also overrides the settings of Bits[9:0]. [Table 27](#) shows the power-down register.

RESET FUNCTION

The AD5593R can be reset to its default conditions by writing 0x0DAC to the software reset register (pointer byte = 0b00001111). This resets all registers to their default values and reconfigures the I/Ox pins to their default values (85 kΩ pull-down to GND). The reset function is triggered on the SCL falling edge of the eighth bit of the least significant byte (Bit 0 of Frame 4 in [Figure 36](#)), and the AD5593R does not generate an ACK signal for this byte of data. The AD5593R has a $\overline{\text{RESET}}$ pin that performs the same function. For normal operation, $\overline{\text{RESET}}$ is tied high. A falling edge on $\overline{\text{RESET}}$ triggers the reset function. Both the hardware and the software reset functions take 250 μs maximum and there must be no activity on the SCL pin of the AD5593R during this time.

APPLICATIONS INFORMATION

MICROPROCESSOR INTERFACING

Microprocessor interfacing to the AD5593R is via a serial bus using a standard I²C protocol. The communications channel requires a 2-wire interface consisting of a clock signal and a data signal.

AD5593R TO ADSP-BF537 INTERFACE

The I²C interface of the AD5593R is designed to be easily connected to industry-standard DSPs and microcontrollers. Figure 43 shows the AD5593R connected to the Analog Devices Blackfin[®] DSP. The Blackfin has an integrated I²C port that can be connected directly to the I²C pins of the AD5593R.

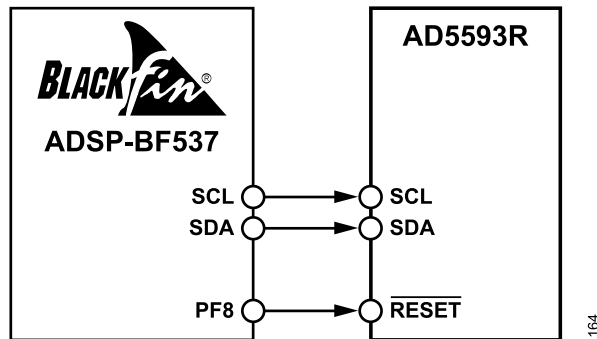

Figure 43. ADSP-BF537 Interface

LAYOUT GUIDELINES

In any circuit where accuracy is important, careful consideration of the power supply and ground return layout helps to ensure the rated performance. The printed circuit board (PCB) on which the AD5593R is mounted must be designed so that the AD5593R lies on the analog plane.

The AD5593R must have ample supply bypassing of 10 μ F in parallel with 0.1 μ F on each supply, located as close to the package as possible, ideally right up against the device. The 10 μ F capacitors are the tantalum bead type. The 0.1 μ F capacitor must have low effective series resistance (ESR) and low effective series inductance (ESI) such as the common ceramic types, which provide a low impedance path to ground at high frequencies to handle transient currents due to internal logic switching.

REGISTER MAP

The AD5593R has programmable user configuration registers that are used to configure the device. [Table 8](#) shows a complete list of the pointer byte registers that select the operation to be executed. See [Table 9](#) and the [Register Details: AD5593R Pointer Byte Map](#) section for details about the functions of each of the bits.

See the [Register Details: AD5593R Control Register Map](#) section for details about the functions of each of the bits.

The [Register Details: AD5593R ADC and DAC Readback](#) section provides data formats for the ADC and the DAC readback.

[Table 10](#) shows a complete list of the control registers that configure the I/O pins and various operating parameters in the AD5593R.

REGISTER SUMMARY: AD5593R POINTER BYTE MAP

Table 8. POINTER_BYTE Register Summary

Pointer Byte Bits[7:4]	Name	Description
0x0	CONFIG_MODE_POINTER	Configuration mode.
0x1	DAC_WR_POINTER	DAC write mode.
0x4	ADC_RD_POINTER	ADC readback mode.
0x5	DAC_RD_POINTER	DAC readback mode.
0x6	GPIO_RD_POINTER	GPIO readback mode.
0x7	REG_RD_POINTER	Register readback mode.

REGISTER SUMMARY (BIT-WISE): AD5593R POINTER BYTE MAP

Table 9. AD5593R_POINTER MAP Register Summary

Mode Bits		Mode Bits				Mode Dependent Data Bits				
Bits[7:4]	Name	Bits	Bit 7	Bit 6	Bit 5	Bit 4	Bit 3	Bit 2	Bit 1	Bit 0
0x0	CONFIG_MODE_POINTER	[7:0]	CONFIG_MODE_SEL				CONFIG_MODE_BITS			
0x1	DAC_WR_POINTER	[7:0]	DAC_WR_SEL				DAC_CH_SEL_WR			
0x4	ADC_RD_POINTER	[7:0]	ADC_RD_SEL				RESERVED			
0x5	DAC_RD_POINTER	[7:0]	DAC_RD_SEL				DAC_CH_SEL_RD			
0x6	GPIO_RD_POINTER	[7:0]	GPIO_RD_SEL				RESERVED			
0x7	REG_RD_POINTER	[7:0]	REG_RD_SEL				REG_SEL_RD			

REGISTER SUMMARY: AD5593R CONTROL REGISTER MAP

Table 10. AD5593R_CORE Register Summary

Pointer Byte Bits[7:0]	Name	Description	Reset Data Bits[15:0]
0x00	NOP	NOP.	0x0000
0x02	ADC_SEQ	ADC Sequence Register.	0x0000
0x03	GEN_CTRL_REG	General-Purpose Control Register.	0x0000
0x04	ADC_CONFIG	ADC Pin Configuration Register.	0x0000
0x05	DAC_CONFIG	DAC Pin Configuration Register.	0x0000
0x06	PULLDWN_CONFIG	Pull-Down Configuration Register.	0x00FF
0x07	LDAC_MODE	LDAC Mode Register.	0x0000
0x08	GPIO_CONFIG	GPIO Write Configuration Register.	0x0000
0x09	GPIO_OUTPUT	GPIO Write Data Register.	0x0000
0x0A	GPIO_INPUT	GPIO Read Configuration Register.	0x0000
0x0B	PD_REF_CTRL	Power-Down/Reference Control Register.	0x0000
0x0C	GPIO_OPENDRAIN_CONFIG	GPIO Open-Drain Configuration Register.	0x0000
0x0D	IO_TS_CONFIG	Three-State Configuration Register.	0x0000

REGISTER MAP

Table 10. AD5593R_CORE Register Summary (Continued)

Pointer Byte Bits[7:0]	Name	Description	Reset Data Bits[15:0]
0x0F	SW_RESET	Software Reset.	0x0000
0x10	DAC_WR	DAC Write Register.	0x0000

REGISTER DETAILS: AD5593R POINTER BYTE MAP

Configuration Mode Register

Reset: 0x00, Name: CONFIG_MODE_POINTER

Pointer byte configuration register.

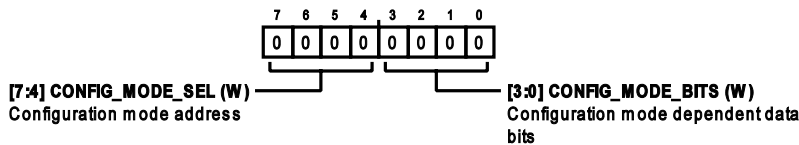

Table 11. Bit Descriptions for CONFIG_MODE_POINTER

Bits	Bit Name	Description	Reset	Access
[7:4]	CONFIG_MODE_SEL	Configuration mode address.	0x0	W
[3:0]	CONFIG_MODE_BITS	Configuration mode dependent data bits. 0000: NOP. No operation. 0010: ADC sequence register. Selects ADCs for conversion. 0011: General-purpose control register. DAC and ADC control register. 0100: ADC pin configuration. Selects which pins are ADC inputs. 0101: DAC pin configuration. Selects which pins are DAC outputs. 0110: Pull-down configuration. Selects which pins have an 85 kΩ pull-down resistor to GND. 0111: LDAC mode. Selects the operation of the load DAC. 1000: GPIO write configuration. Selects which pins are general-purpose outputs. 1001: GPIO write data. Writes data to general-purpose outputs. 1010: GPIO read configuration. Selects which pins are general-purpose inputs. 1011: Power-down/reference control. Powers down the DACs and enables/disables the reference. 1100: Open-drain configuration. Selects open-drain or push-pull for general-purpose outputs. 1101: Three-state pins. Selects which pins are three-stated. 1111: Software reset. Resets the AD5593R.	0x0	W

DAC Write Mode Register

Reset: 0x10, Name: DAC_WR_POINTER

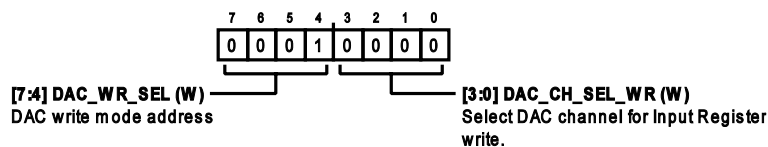

Table 12. Bit Descriptions for DAC_WR_POINTER

Bits	Bit Name	Description	Reset	Access
[7:4]	DAC_WR_SEL	DAC write mode address.	0x1	W

REGISTER MAP

Table 12. Bit Descriptions for DAC_WR_POINTER (Continued)

Bits	Bit Name	Description	Reset	Access
[3:0]	DAC_CH_SEL_WR	Select DAC channel for input register write. 000: DAC0. 001: DAC1. 010: DAC2. 011: DAC3. 100: DAC4. 101: DAC5. 110: DAC6. 111: DAC7.	0x0	W

ADC Readback Mode Register

Reset: 0x40, Name: ADC_RD_POINTER

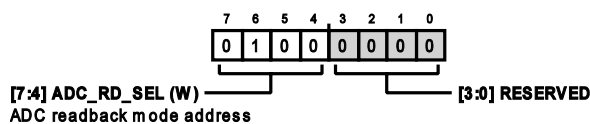

Table 13. Bit Descriptions for ADC_RD_POINTER

Bits	Bit Name	Description	Reset	Access
[7:4]	ADC_RD_SEL	ADC readback mode address.	0x4	W
[3:0]	RESERVED	Reserved.	0x0	R

DAC Readback Mode Register

Reset: 0x50, Name: DAC_RD_POINTER

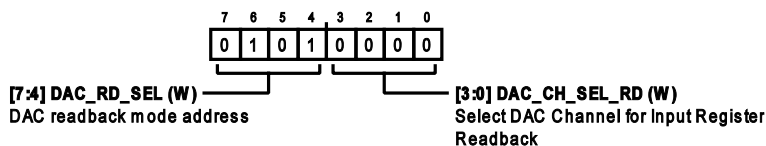

Table 14. Bit Descriptions for DAC_RD_POINTER

Bits	Bit Name	Description	Reset	Access
[7:4]	DAC_RD_SEL	DAC readback mode address.	0x5	W
[3:0]	DAC_CH_SEL_RD	Select DAC channel for input register readback. 000: DAC0. 001: DAC1. 010: DAC2. 011: DAC3. 100: DAC4. 101: DAC5. 110: DAC6. 111: DAC7.	0x0	W

REGISTER MAP

GPIO Readback Mode Register

Reset: 0x60, Name: GPIO_RD_POINTER

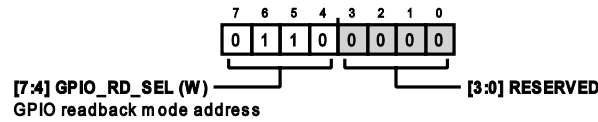

Table 15. Bit Descriptions for GPIO_RD_POINTER

Bits	Bit Name	Description	Reset	Access
[7:4]	GPIO_RD_SEL	GPIO readback mode address.	0x6	W
[3:0]	RESERVED	Reserved.	0x0	R

Register Readback Mode

Reset: 0x70, Name: REG_RD_POINTER

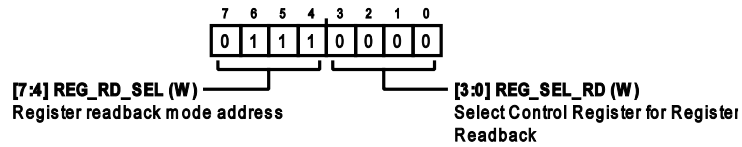

Table 16. Bit Descriptions for REG_RD_POINTER

Bits	Bit Name	Description	Reset	Access
[7:4]	REG_RD_SEL	Register readback mode address.	0x7	W
[3:0]	REG_SEL_RD	Select control register for register readback. 0000: NOP. 0010: ADC sequence register. 0011: General-purpose control register. 0100: ADC pin configuration. 0101: DAC pin configuration. 0110: Pull-down configuration. 0111: LDAC mode. 1000: GPIO write configuration. 1001: GPIO write data. 1010: GPIO read configuration. 1011: Power-down/reference control. 1100: Open-drain configuration. 1101: Three-state pins.	0x0	W

REGISTER DETAILS: AD5593R CONTROL REGISTER MAP

NOP Register

Reset: 0x0000, Name: NOP

No operation.

REGISTER MAP

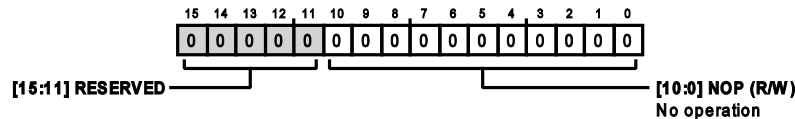

Table 17. Bit Descriptions for NOP

Bits	Bit Name	Description	Reset	Access
[15:11]	RESERVED	Reserved.	0x0	R
[10:0]	NOP	No operation.	0x0	R/W

ADC Sequence Register

Reset: 0x0000, Name: ADC_SEQ

Selects ADCs for conversion.

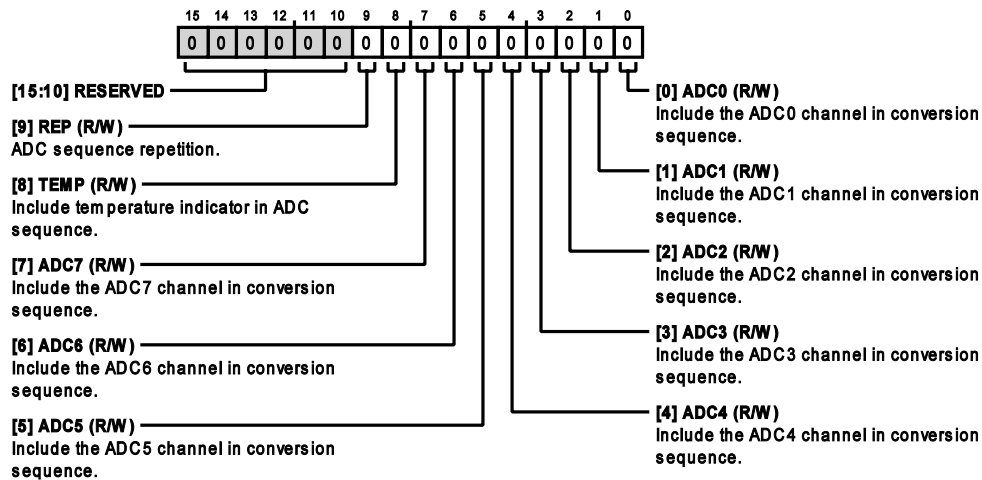

Table 18. Bit Descriptions for ADC_SEQ

Bits	Bit Name	Description	Reset	Access
[15:10]	RESERVED	Reserved.	0x0	R
9	REP	ADC sequence repetition. 0: Sequence repetition disabled. 1: Sequence repetition enabled.	0x0	R/W
8	TEMP	Include temperature indicator in ADC sequence. 0: Disable temperature indicator readback. 1: Enable temperature indicator readback.	0x0	R/W
7	ADC7	Include the ADC7 channel in conversion sequence. 0: The selected ADC channel is not included in the conversion sequence. 1: Include the selected ADC channel in the conversion sequence.	0x0	R/W
6	ADC6	Include the ADC6 channel in conversion sequence. 0: The selected ADC channel is not included in the conversion sequence. 1: Include the selected ADC channel in the conversion sequence.	0x0	R/W
5	ADC5	Include the ADC5 channel in conversion sequence. 0: The selected ADC channel is not included in the conversion sequence.	0x0	R/W

REGISTER MAP

Table 18. Bit Descriptions for ADC_SEQ (Continued)

Bits	Bit Name	Description	Reset	Access
		1: Include the selected ADC channel in the conversion sequence.		
4	ADC4	Include the ADC4 channel in conversion sequence. 0: The selected ADC channel is not included in the conversion sequence. 1: Include the selected ADC channel in the conversion sequence.	0x0	R/W
3	ADC3	Include the ADC3 channel in conversion sequence. 0: The selected ADC channel is not included in the conversion sequence. 1: Include the selected ADC channel in the conversion sequence.	0x0	R/W
2	ADC2	Include the ADC2 channel in conversion sequence. 0: The selected ADC channel is not included in the conversion sequence. 1: Include the selected ADC channel in the conversion sequence.	0x0	R/W
1	ADC1	Include the ADC1 channel in conversion sequence. 0: The selected ADC channel is not included in the conversion sequence. 1: Include the selected ADC channel in the conversion sequence.	0x0	R/W
0	ADC0	Include the ADC0 channel in conversion sequence. 0: The selected ADC channel is not included in the conversion sequence. 1: Include the selected ADC channel in the conversion sequence.	0x0	R/W

General-Purpose Control Register

Reset: 0x0000, Name: GEN_CTRL_REG

DAC and ADC control register.

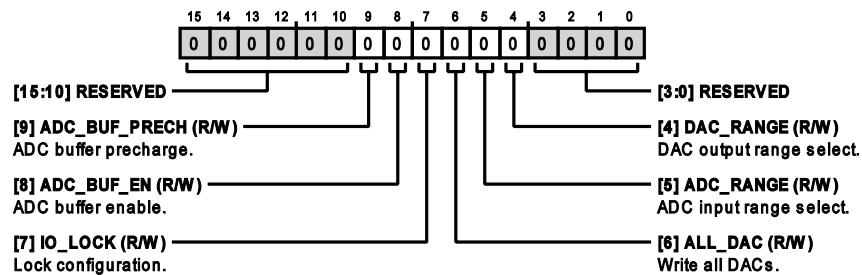

Table 19. Bit Descriptions for GEN_CTRL_REG

Bits	Bit Name	Description	Reset	Access
[15:10]	RESERVED	Reserved.	0x0	R
9	ADC_BUF_PRECH	ADC buffer precharge. 0: ADC buffer is not used to precharge the ADC. If the ADC buffer is enabled, it is always powered up. 1: ADC buffer is used to precharge the ADC. If the ADC buffer is enabled, it is powered up while the conversion takes place and then powered down until the next conversion takes place.	0x0	R/W
8	ADC_BUF_EN	ADC buffer enable. 0: ADC buffer is disabled. 1: ADC buffer is enabled.	0x0	R/W
7	IO_LOCK	Lock configuration. 0: The contents of the I/Ox pin configuration register can be changed. 1: The contents of the I/Ox pin configuration register cannot be changed.	0x0	R/W
6	ALL_DAC	Write all DACs.	0x0	R/W

REGISTER MAP

Table 19. Bit Descriptions for GEN_CTRL_REG (Continued)

Bits	Bit Name	Description	Reset	Access
		0: For future DAC writes, the DAC address bits determine which DAC is written to. 1: For future DAC writes, the DAC address bits are ignored, and all channels configured as DACs are updated with the same data.		
5	ADC_RANGE	ADC input range select. 0: ADC gain is 0 V to VREF. 1: ADC gain is 0 V to 2 × VREF.	0x0	R/W
4	DAC_RANGE	DAC output range select. 0: DAC output range is 0 V to VREF. 1: DAC output range is 0 V to 2 × VREF.	0x0	R/W
[3:0]	RESERVED	Reserved.	0x0	R

ADC Pin Configuration Register

Reset: 0x0000, Name: ADC_CONFIG

Selects which pins are ADC inputs.

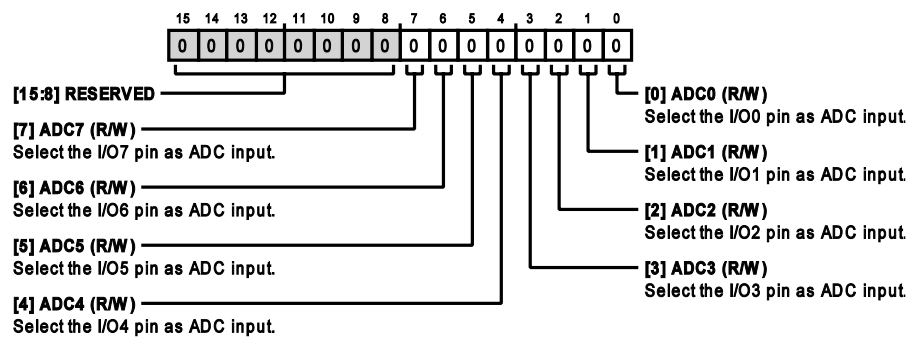

Table 20. Bit Descriptions for ADC_CONFIG

Bits	Bit Name	Description	Reset	Access
[15:8]	RESERVED	Reserved.	0x0	R
7	ADC7	Select the I/O7 pin as ADC input. 0: The I/O pin function is determined by the pin configuration registers. 1: The I/O pin is an ADC input.	0x0	R/W
6	ADC6	Select the I/O6 pin as ADC input. 0: The I/O pin function is determined by the pin configuration registers. 1: The I/O pin is an ADC input.	0x0	R/W
5	ADC5	Select the I/O5 pin as ADC input. 0: The I/O pin function is determined by the pin configuration registers. 1: The I/O pin is an ADC input.	0x0	R/W
4	ADC4	Select the I/O4 pin as ADC input. 0: The I/O pin function is determined by the pin configuration registers. 1: The I/O pin is an ADC input.	0x0	R/W
3	ADC3	Select the I/O3 pin as ADC input. 0: The I/O pin function is determined by the pin configuration registers. 1: The I/O pin is an ADC input.	0x0	R/W

REGISTER MAP

Table 20. Bit Descriptions for ADC_CONFIG (Continued)

Bits	Bit Name	Description	Reset	Access
2	ADC2	Select the I/O2 pin as ADC input. 0: The I/O pin function is determined by the pin configuration registers. 1: The I/O pin is an ADC input.	0x0	R/W
1	ADC1	Select the I/O1 pin as ADC input. 0: The I/O pin function is determined by the pin configuration registers. 1: The I/O pin is an ADC input.	0x0	R/W
0	ADC0	Select the I/O0 pin as ADC input. 0: The I/O pin function is determined by the pin configuration registers. 1: The I/O pin is an ADC input.	0x0	R/W

DAC Pin Configuration Register

Reset: 0x0000, Name: DAC_CONFIG

Selects which pins are DAC outputs.

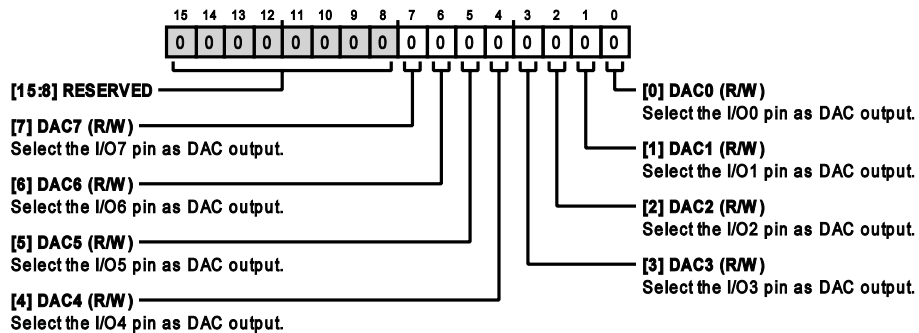

Table 21. Bit Descriptions for DAC_CONFIG

Bits	Bit Name	Description	Reset	Access
[15:8]	RESERVED	Reserved.	0x0	R
7	DAC7	Select the I/O7 pin as DAC output. 0: The I/O pin function is determined by the pin configuration registers. 1: The I/O pin is a DAC output.	0x0	R/W
6	DAC6	Select the I/O6 pin as DAC output. 0: The I/O pin function is determined by the pin configuration registers. 1: The I/O pin is a DAC output.	0x0	R/W
5	DAC5	Select the I/O5 pin as DAC output. 0: The I/O pin function is determined by the pin configuration registers. 1: The I/O pin is a DAC output.	0x0	R/W
4	DAC4	Select the I/O4 pin as DAC output. 0: The I/O pin function is determined by the pin configuration registers. 1: The I/O pin is a DAC output.	0x0	R/W
3	DAC3	Select the I/O3 pin as DAC output. 0: The I/O pin function is determined by the pin configuration registers. 1: The I/O pin is a DAC output.	0x0	R/W
2	DAC2	Select the I/O2 pin as DAC output.	0x0	R/W

REGISTER MAP

Table 21. Bit Descriptions for DAC_CONFIG (Continued)

Bits	Bit Name	Description	Reset	Access
1	DAC1	0: The I/O pin function is determined by the pin configuration registers. 1: The I/O pin is a DAC output. Select the I/O1 pin as DAC output.	0x0	R/W
0	DAC0	0: The I/O pin function is determined by the pin configuration registers. 1: The I/O pin is a DAC output. Select the I/O0 pin as DAC output.	0x0	R/W

Pull-Down Configuration Register

Reset: 0x00FF, Name: PULLDWN_CONFIG

Selects which pins have an 85 kΩ pull-down resistor to GND.

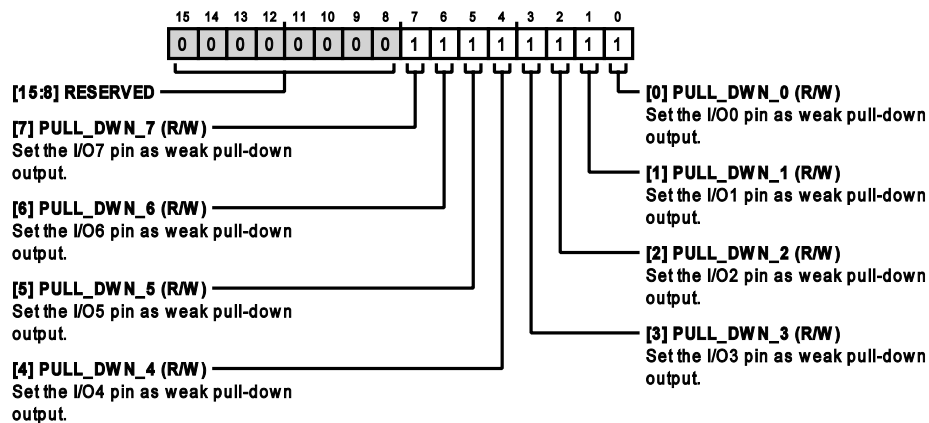

Table 22. Bit Descriptions for PULLDWN_CONFIG

Bits	Bit Name	Description	Reset	Access
[15:8]	RESERVED	Reserved.	0x0	R
7	PULL_DWN_7	Set the I/O7 pin as weak pull-down output. 0: The I/O pin function is determined by the pin configuration registers. 1: The I/O pin is connected to GND via an 85 kΩ pull-down resistor.	0x1	R/W
6	PULL_DWN_6	Set the I/O6 pin as weak pull-down output. 0: The I/O pin function is determined by the pin configuration registers. 1: The I/O pin is connected to GND via an 85 kΩ pull-down resistor.	0x1	R/W
5	PULL_DWN_5	Set the I/O5 pin as weak pull-down output. 0: The I/O pin function is determined by the pin configuration registers. 1: The I/O pin is connected to GND via an 85 kΩ pull-down resistor.	0x1	R/W
4	PULL_DWN_4	Set the I/O4 pin as weak pull-down output. 0: The I/O pin function is determined by the pin configuration registers. 1: The I/O pin is connected to GND via an 85 kΩ pull-down resistor.	0x1	R/W
3	PULL_DWN_3	Set the I/O3 pin as weak pull-down output. 0: The I/O pin function is determined by the pin configuration registers. 1: The I/O pin is connected to GND via an 85 kΩ pull-down resistor.	0x1	R/W

REGISTER MAP

Table 22. Bit Descriptions for PULLDOWN_CONFIG (Continued)

Bits	Bit Name	Description	Reset	Access
2	PULL_DWN_2	Set the I/O2 pin as weak pull-down output. 0: The I/O pin function is determined by the pin configuration registers. 1: The I/O pin is connected to GND via an 85 kΩ pull-down resistor.	0x1	R/W
1	PULL_DWN_1	Set the I/O1 pin as weak pull-down output. 0: The I/O pin function is determined by the pin configuration registers. 1: The I/O pin is connected to GND via an 85 kΩ pull-down resistor.	0x1	R/W
0	PULL_DWN_0	Set the I/O0 pin as weak pull-down output. 0: The I/O pin function is determined by the pin configuration registers. 1: The I/O pin is connected to GND via an 85 kΩ pull-down resistor.	0x1	R/W

LDAC Mode Register

Reset: 0x0000, Name: LDAC_MODE

Selects the operation of the load DAC (LDAC) function.

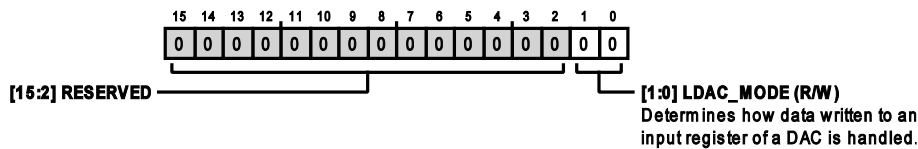

Table 23. Bit Descriptions for LDAC_MODE

Bits	Bit Name	Description	Reset	Access
[15:2]	RESERVED	Reserved.	0x0	R
[1:0]	LDAC_MODE	Determines how data written to an input register of a DAC is handled. 00: Data written to an input register is immediately copied to a DAC register, and the DAC output updates. 01: Data written to an input register is not copied to a DAC register. The DAC output is not updated. 10: Data in the input registers is copied to the corresponding DAC registers. When the data has been transferred, the DAC outputs are updated simultaneously.	0x0	R/W

GPIO Write Configuration Register

Reset: 0x0000, Name: GPIO_CONFIG

Selects which pins are general-purpose outputs.

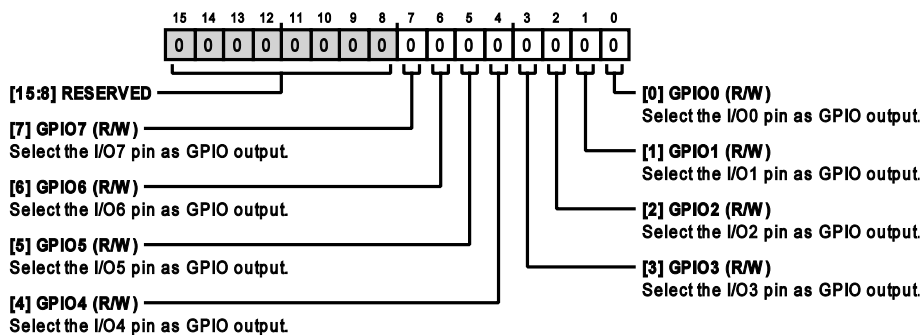

REGISTER MAP

Table 24. Bit Descriptions for GPIO_CONFIG

Bits	Bit Name	Description	Reset	Access
[15:8]	RESERVED	Reserved.	0x0	R
7	GPIO7	Select the I/O7 pin as GPIO output. 0: The I/O pin function is determined by the pin configuration registers. 1: The I/O pin is a general-purpose output pin.	0x0	R/W
6	GPIO6	Select the I/O6 pin as GPIO output. 0: The I/O pin function is determined by the pin configuration registers. 1: The I/O pin is a general-purpose output pin.	0x0	R/W
5	GPIO5	Select the I/O5 pin as GPIO output. 0: The I/O pin function is determined by the pin configuration registers. 1: The I/O pin is a general-purpose output pin.	0x0	R/W
4	GPIO4	Select the I/O4 pin as GPIO output. 0: The I/O pin function is determined by the pin configuration registers. 1: The I/O pin is a general-purpose output pin.	0x0	R/W
3	GPIO3	Select the I/O3 pin as GPIO output. 0: The I/O pin function is determined by the pin configuration registers. 1: The I/O pin is a general-purpose output pin.	0x0	R/W
2	GPIO2	Select the I/O2 pin as GPIO output. 0: The I/O pin function is determined by the pin configuration registers. 1: The I/O pin is a general-purpose output pin.	0x0	R/W
1	GPIO1	Select the I/O1 pin as GPIO output. 0: The I/O pin function is determined by the pin configuration registers. 1: The I/O pin is a general-purpose output pin.	0x0	R/W
0	GPIO0	Select the I/O0 pin as GPIO output. 0: The I/O pin function is determined by the pin configuration registers. 1: The I/O pin is a general-purpose output pin.	0x0	R/W

GPIO Write Data Register

Reset: 0x0000, Name: GPIO_OUTPUT

Writes data to the general-purpose outputs.

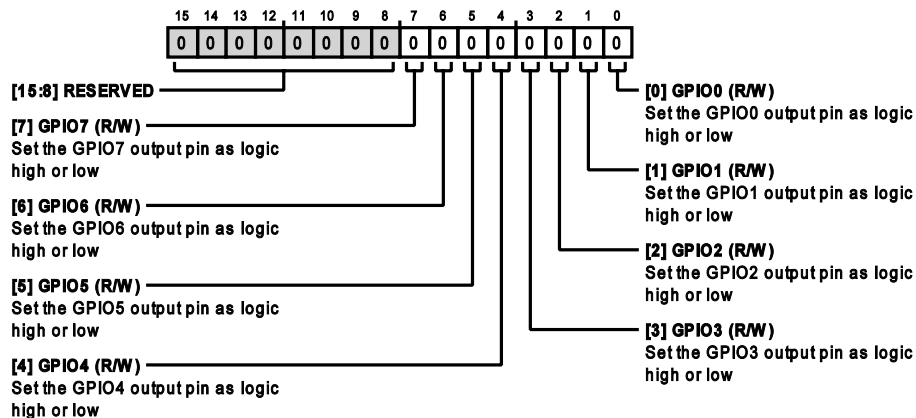

REGISTER MAP

Table 25. Bit Descriptions for GPIO_OUTPUT

Bits	Bit Name	Description	Reset	Access
[15:8]	RESERVED	Reserved.	0x0	R
7	GPIO7	Set the GPIO7 output pin as logic high or low. 0: The I/O pin is a Logic 0 output. 1: The I/O pin is a Logic 1 output.	0x0	R/W
6	GPIO6	Set the GPIO6 output pin as logic high or low. 0: The I/O pin is a Logic 0 output. 1: The I/O pin is a Logic 1 output.	0x0	R/W
5	GPIO5	Set the GPIO5 output pin as logic high or low. 0: The I/O pin is a Logic 0 output. 1: The I/O pin is a Logic 1 output.	0x0	R/W
4	GPIO4	Set the GPIO4 output pin as logic high or low. 0: The I/O pin is a Logic 0 output. 1: The I/O pin is a Logic 1 output.	0x0	R/W
3	GPIO3	Set the GPIO3 output pin as logic high or low. 0: The I/O pin is a Logic 0 output. 1: The I/O pin is a Logic 1 output.	0x0	R/W
2	GPIO2	Set the GPIO2 output pin as logic high or low. 0: The I/O pin is a Logic 0 output. 1: The I/O pin is a Logic 1 output.	0x0	R/W
1	GPIO1	Set the GPIO1 output pin as logic high or low. 0: The I/O pin is a Logic 0 output. 1: The I/O pin is a Logic 1 output.	0x0	R/W
0	GPIO0	Set the GPIO0 output pin as logic high or low. 0: The I/O pin is a Logic 0 output. 1: The I/O pin is a Logic 1 output.	0x0	R/W

GPIO Read Configuration Register

Reset: 0x0000, Name: GPIO_INPUT

Selects which pins are general-purpose inputs.

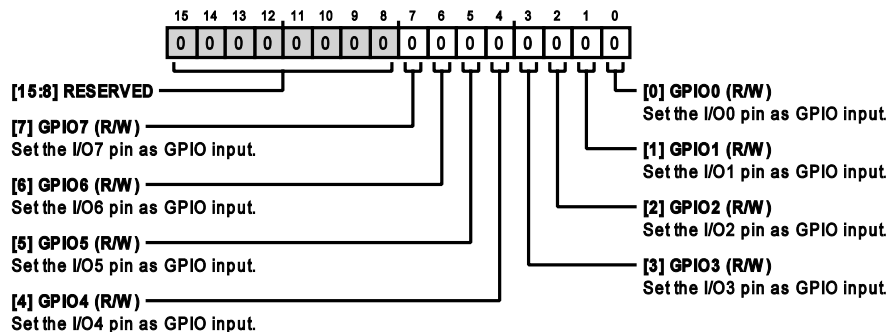

Table 26. Bit Descriptions for GPIO_INPUT

Bits	Bit Name	Description	Reset	Access
[15:8]	RESERVED	Reserved.	0x0	R

REGISTER MAP

Table 26. Bit Descriptions for GPIO_INPUT (Continued)

Bits	Bit Name	Description	Reset	Access
7	GPIO7	Set the I/O7 pin as GPIO input. 0: The I/O pin function is determined by the pin configuration registers. 1: The I/O pin is a general-purpose input pin.	0x0	R/W
6	GPIO6	Set the I/O6 pin as GPIO input. 0: The I/O pin function is determined by the pin configuration registers. 1: The I/O pin is a general-purpose input pin.	0x0	R/W
5	GPIO5	Set the I/O5 pin as GPIO input. 0: The I/O pin function is determined by the pin configuration registers. 1: The I/O pin is a general-purpose input pin.	0x0	R/W
4	GPIO4	Set the I/O4 pin as GPIO input. 0: The I/O pin function is determined by the pin configuration registers. 1: The I/O pin is a general-purpose input pin.	0x0	R/W
3	GPIO3	Set the I/O3 pin as GPIO input. 0: The I/O pin function is determined by the pin configuration registers. 1: The I/O pin is a general-purpose input pin.	0x0	R/W
2	GPIO2	Set the I/O2 pin as GPIO input. 0: The I/O pin function is determined by the pin configuration registers. 1: The I/O pin is a general-purpose input pin.	0x0	R/W
1	GPIO1	Set the I/O1 pin as GPIO input. 0: The I/O pin function is determined by the pin configuration registers. 1: The I/O pin is a general-purpose input pin.	0x0	R/W
0	GPIO0	Set the I/O0 pin as GPIO input. 0: The I/O pin function is determined by the pin configuration registers. 1: The I/O pin is a general-purpose input pin.	0x0	R/W

Power-Down/Reference Control Register

Reset: 0x0000, Name: PD_REF_CTRL

Powers down DACs and enables/disables the reference.

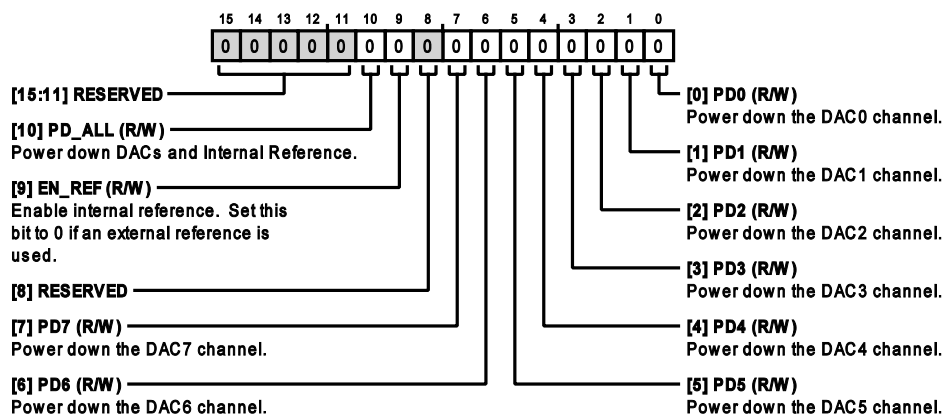

REGISTER MAP

Table 27. Bit Descriptions for PD_REF_CTRL

Bits	Bit Name	Description	Reset	Access
[15:11]	RESERVED	Reserved.	0x0	R
10	PD_ALL	Power down DACs and Internal Reference. 0: The reference and DACs power-down states are determined by EN_REF and PD7 to PD0 bits. 1: The reference, DACs and ADC are powered down.	0x0	R/W
9	EN_REF	Enable internal reference. Set this bit to 0 if an external reference is used. 0: The reference and its buffer are powered down. 1: The reference and its buffer are powered up. The reference is available on the VREF pin.	0x0	R/W
8	RESERVED	Reserved.	0x0	R
7	PD7	Power down the DAC7 channel. 0: The channel is in normal operating mode. 1: The channel is powered down if it is configured as a DAC.	0x0	R/W
6	PD6	Power down the DAC6 channel. 0: The channel is in normal operating mode. 1: The channel is powered down if it is configured as a DAC.	0x0	R/W
5	PD5	Power down the DAC5 channel. 0: The channel is in normal operating mode. 1: The channel is powered down if it is configured as a DAC.	0x0	R/W
4	PD4	Power down the DAC4 channel. 0: The channel is in normal operating mode. 1: The channel is powered down if it is configured as a DAC.	0x0	R/W
3	PD3	Power down the DAC3 channel. 0: The channel is in normal operating mode. 1: The channel is powered down if it is configured as a DAC.	0x0	R/W
2	PD2	Power down the DAC2 channel. 0: The channel is in normal operating mode. 1: The channel is powered down if it is configured as a DAC.	0x0	R/W
1	PD1	Power down the DAC1 channel. 0: The channel is in normal operating mode. 1: The channel is powered down if it is configured as a DAC.	0x0	R/W
0	PD0	Power down the DAC0 channel. 0: The channel is in normal operating mode. 1: The channel is powered down if it is configured as a DAC.	0x0	R/W

GPIO Open-Drain Configuration Register

Reset: 0x0000, Name: GPIO_OPENDRAIN_CONFIG

Selects open-drain or push/pull for general-purpose outputs. The selected I/O pin must be set as digital output pin in the GPIO_CONFIG register.

REGISTER MAP

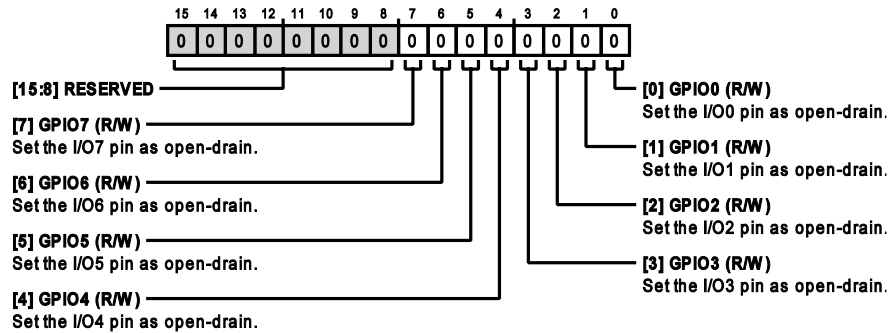

Table 28. Bit Descriptions for GPIO_OPENDRAIN_CONFIG

Bits	Bit Name	Description	Reset	Access
[15:8]	RESERVED	Reserved.	0x0	R
7	GPIO7	Set the I/O7 pin as open-drain. 0: The I/O pin is a push/pull output pin. 1: The I/O pin is an open-drain output pin.	0x0	R/W
6	GPIO6	Set the I/O6 pin as open-drain. 0: The I/O pin is a push/pull output pin. 1: The I/O pin is an open-drain output pin.	0x0	R/W
5	GPIO5	Set the I/O5 pin as open-drain. 0: The I/O pin is a push/pull output pin. 1: The I/O pin is an open-drain output pin.	0x0	R/W
4	GPIO4	Set the I/O4 pin as open-drain. 0: The I/O pin is a push/pull output pin. 1: The I/O pin is an open-drain output pin.	0x0	R/W
3	GPIO3	Set the I/O3 pin as open-drain. 0: The I/O pin is a push/pull output pin. 1: The I/O pin is an open-drain output pin.	0x0	R/W
2	GPIO2	Set the I/O2 pin as open-drain. 0: The I/O pin is a push/pull output pin. 1: The I/O pin is an open-drain output pin.	0x0	R/W
1	GPIO1	Set the I/O1 pin as open-drain. 0: The I/O pin is a push/pull output pin. 1: The I/O pin is an open-drain output pin.	0x0	R/W
0	GPIO0	Set the I/O0 pin as open-drain. 0: The I/O pin is a push/pull output pin. 1: The I/O pin is an open-drain output pin.	0x0	R/W

Three-State Configuration Register

Reset: 0x0000, Name: IO_TS_CONFIG

Selects which pins are three-state.

REGISTER MAP

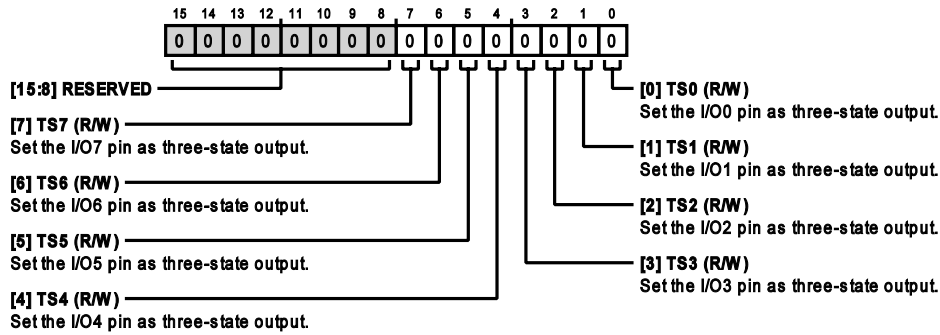

Table 29. Bit Descriptions for IO_TS_CONFIG

Bits	Bit Name	Description	Reset	Access
[15:8]	RESERVED	Reserved.	0x0	R
7	TS7	Set the I/O7 pin as three-state output. 0: The I/O pin function is determined by the pin configuration registers. 1: The I/O pin is a three-state output pin.	0x0	R/W
6	TS6	Set the I/O6 pin as three-state output. 0: The I/O pin function is determined by the pin configuration registers. 1: The I/O pin is a three-state output pin.	0x0	R/W
5	TS5	Set the I/O5 pin as three-state output. 0: The I/O pin function is determined by the pin configuration registers. 1: The I/O pin is a three-state output pin.	0x0	R/W
4	TS4	Set the I/O4 pin as three-state output. 0: The I/O pin function is determined by the pin configuration registers. 1: The I/O pin is a three-state output pin.	0x0	R/W
3	TS3	Set the I/O3 pin as three-state output. 0: The I/O pin function is determined by the pin configuration registers. 1: The I/O pin is a three-state output pin.	0x0	R/W
2	TS2	Set the I/O2 pin as three-state output. 0: The I/O pin function is determined by the pin configuration registers. 1: The I/O pin is a three-state output pin.	0x0	R/W
1	TS1	Set the I/O1 pin as three-state output. 0: The I/O pin function is determined by the pin configuration registers. 1: The I/O pin is a three-state output pin.	0x0	R/W
0	TS0	Set the I/O0 pin as three-state output. 0: The I/O pin function is determined by the pin configuration registers. 1: The I/O pin is a three-state output pin.	0x0	R/W

Software Reset Register

Reset: 0x0000, Name: SW_RESET

Resets the AD5593R.

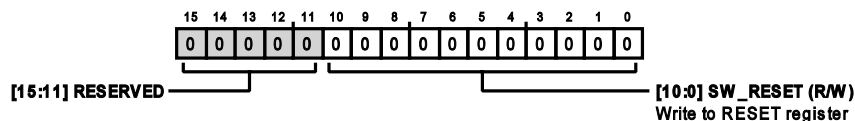

REGISTER MAP

Table 30. Bit Descriptions for SW_RESET

Bits	Bit Name	Description	Reset	Access
[15:11]	RESERVED	Reserved.	0x0	R
[10:0]	SW_RESET	Write to RESET register. 10110101100: Reset the AD5593R.	0x0	R/W

DAC Write Register

Reset: 0x0000, Name: DAC_WR

Writes to addressed DAC register.

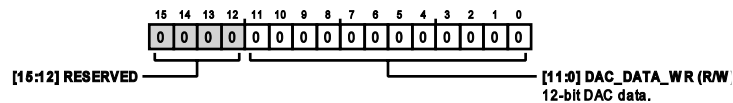

Table 31. Bit Descriptions for DAC_WR

Bits	Bit Name	Description	Reset	Access
[15:12]	RESERVED	Reserved.	0x0	R
[11:0]	DAC_DATA_WR	12-bit DAC data.	0x0	R/W

REGISTER DETAILS: AD5593R ADC AND DAC READBACK

DAC Data Readback Register

Name: DAC_DATA_RD

Read back the 12-bit DAC input register data.

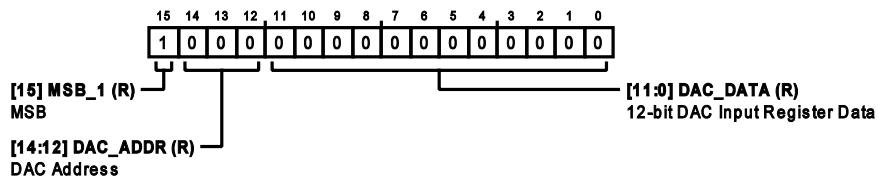

Table 32. Bit Descriptions for DAC_DATA_RD

Bits	Bit Name	Description	Reset
15	MSB	MSB.	0x1
[14:12]	DAC_ADDR	DAC Address. 000: DAC0. 001: DAC1. 010: DAC2. 011: DAC3. 100: DAC4. 101: DAC5. 110: DAC6. 111: DAC7.	0x0
[11:0]	DAC_DATA	12-bit DAC Input Register Data.	0x0

REGISTER MAP

ADC Conversion Result Register

Name: ADC_RESULT

ADC conversion result.

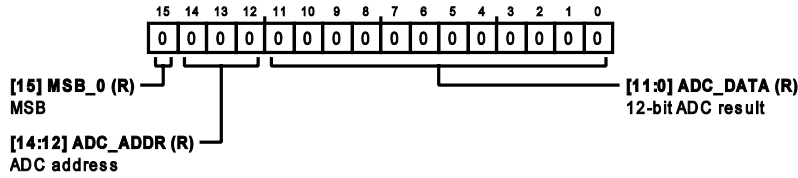

Table 33. Bit Descriptions for ADC_RESULT

Bits	Bit Name	Description	Reset
15	MSB	MSB.	0x0
[14:12]	ADC_ADDR	ADC address. 000: ADC0. 001: ADC1. 010: ADC2. 011: ADC3. 100: ADC4. 101: ADC5. 110: ADC6. 111: ADC7.	0x0
[11:0]	ADC_DATA	12-bit ADC result.	0x0

Temperature Reading Register

Name: TMP_SENSE_RESULT

Temperature reading.

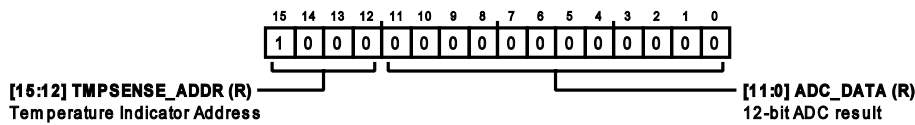

Table 34. Bit Descriptions for TMP_SENSE_RESULT

Bits	Bit Name	Description	Reset
[15:12]	TMPSENSE_ADDR	Temperature Indicator Address.	0x8
[11:0]	ADC_DATA	12-bit ADC Result.	0x0

OUTLINE DIMENSIONS

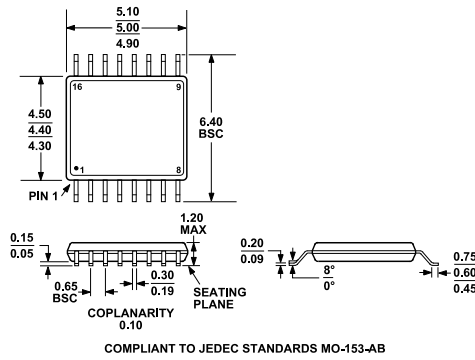

Figure 44. 16-Lead Thin Shrink Small Outline Package [TSSOP] (RU-16)
 Dimensions shown in millimeters

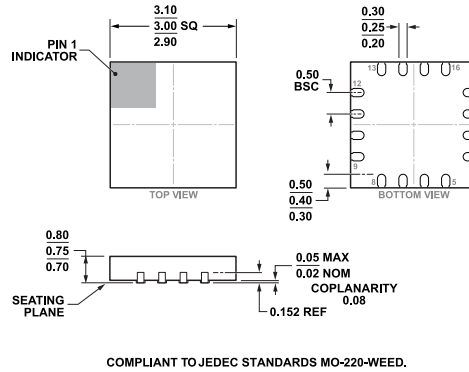

Figure 45. 16-Lead Lead Frame Chip Scale Package [LFCSP] 3 mm x 3 mm Body and 0.75 mm Package Height (CP-16-32)
 Dimensions shown in millimeters

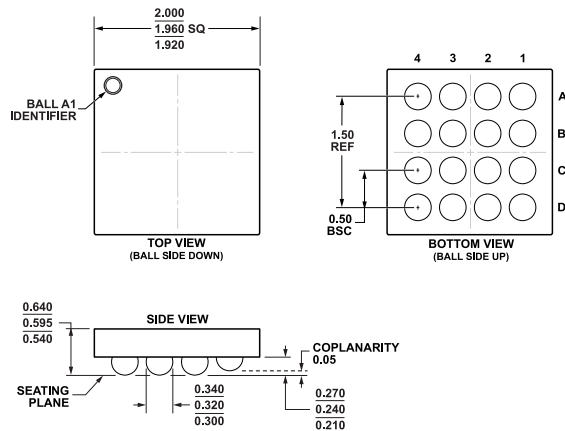

Figure 46. 16-Ball Wafer Level Chip Scale Package [WLCSP] (CB-16-3)
 Dimensions shown in millimeters