

FEATURES

SPI interface with error detection

Includes CRC, invalid read/write address, and SCLK count error detection

Supports burst mode and daisy-chain mode

Industry-standard SPI Mode 0 and SPI Mode 3 compatible

Guaranteed break-before-make switching allowing external wiring of switches to deliver multiplexer configurations

V_{SS} to V_{DD} analog signal range

Fully specified at $\pm 15\text{ V}$ and $+12\text{ V}$ supply

$\pm 4.5\text{ V}$ to $\pm 16.5\text{ V}$ dual-supply operation

5 V to 16.5 V single-supply operation

Ultralow capacitance and leakage allows fast settling time

1 pF typical off switch drain capacitance at 25°C , $\pm 15\text{ V}$

2.6 pF typical on switch capacitance at 25°C , $\pm 15\text{ V}$

<1 pC typical charge injection at 25°C

1.8 V logic compatibility with $2.7\text{ V} \leq V_L \leq 3.3\text{ V}$

APPLICATIONS

Automated test equipment

Data acquisition systems

Battery-powered systems

Sample-and-hold systems

Audio signal routing

Video signal routing

Communications systems

GENERAL DESCRIPTION

The ADGS1212 contains four independent single-pole/single-throw (SPST) switches. A serial peripheral interface (SPI) controls the switches. The SPI interface has robust error detection features such as cyclic redundancy check (CRC) error detection, invalid read/write address detection, and SCLK count error detection.

It is possible to daisy-chain multiple ADGS1212 devices together. Daisy-chain mode enables the configuration of multiple devices with minimal digital lines. The ADGS1212 can also operate in burst mode to decrease the time between SPI commands.

iCMOS construction ensures ultralow power dissipation, making the device ideal for portable and battery-powered instruments.

Each switch conducts equally well in both directions when on, and each switch has an input signal range that extends to the supplies.

FUNCTIONAL BLOCK DIAGRAM

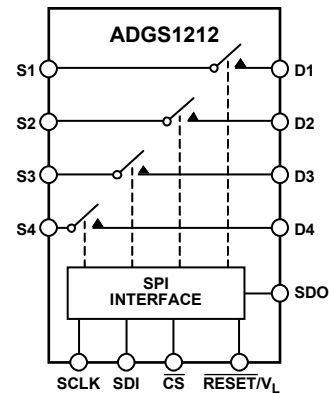

Figure 1.

15936-001

In the off condition, signal levels up to the supplies are blocked.

The ultralow capacitance and charge injection of these switches make them ideal solutions for data acquisition and sample-and-hold applications where low glitch and fast settling are required. Fast switching speed coupled with high signal bandwidth make the device suitable for video signal switching.

Multifunction pin names may be referenced by their relevant function only.

PRODUCT HIGHLIGHTS

1. SPI interface removes the need for parallel conversion, logic traces, and reduces the general-purpose input/output (GPIO) channel count.
2. Daisy-chain mode removes additional logic traces when multiple devices are used.
3. CRC error detection, invalid read/write address detection, and SCLK count error detection ensure a robust digital interface.
4. CRC and error detection capabilities allow the ADGS1212 to be used in safety critical systems.
5. Guaranteed break-before-make switching allows the the ADGS1212 to be used in multiplexer configurations with external wiring.
6. The ADGS1212 1.8 V logic compatibility with $2.7\text{ V} \leq V_L \leq 3.3\text{ V}$
7. Ultralow capacitance.
8. <1 pC charge injection.

Rev. 0

[Document Feedback](#)

Information furnished by Analog Devices is believed to be accurate and reliable. However, no responsibility is assumed by Analog Devices for its use, nor for any infringements of patents or other rights of third parties that may result from its use. Specifications subject to change without notice. No license is granted by implication or otherwise under any patent or patent rights of Analog Devices. Trademarks and registered trademarks are the property of their respective owners.

TABLE OF CONTENTS

Features	1	Error Detection Features	17
Applications	1	Clearing the Error Flags Register	18
General Description	1	Burst Mode	18
Functional Block Diagram	1	Software Reset	18
Product Highlights	1	Daisy-Chain Mode	18
Revision History	2	Power-On Reset	19
Specifications	3	Applications Information	20
±15 V Dual Supply	3	Break-Before-Make Switching	20
12 V Single Supply	5	Power Supply Rails	20
Continuous Current per Channel, Sx or Dx	6	Power Supply Recommendations	20
Timing Characteristics	7	Register Summary	21
Absolute Maximum Ratings	9	Register Details	22
Thermal Resistance	9	Switch Data Register	22
ESD Caution	9	Error Configuration Register	22
Pin Configuration and Function Descriptions	10	Error Flags Register	23
Typical Performance Characteristics	11	Burst Enable Register	23
Test Circuits	14	Software Reset Register	23
Terminology	16	Outline Dimensions	24
Theory of Operation	17	Ordering Guide	24
Address Mode	17		

REVISION HISTORY

9/2017—Revision 0: Initial Version

SPECIFICATIONS

±15 V DUAL SUPPLY

$V_{DD} = +15\text{ V} \pm 10\%$, $V_{SS} = -15\text{ V} \pm 10\%$, $V_L = 2.7\text{ V}$ to 5.5 V , and $GND = 0\text{ V}$, unless otherwise noted.

Table 1.

Parameter	+25°C	-40°C to +85°C	-40°C to +125°C	Unit	Test Conditions/Comments
ANALOG SWITCH					
Analog Signal Range			V_{DD} to V_{SS}	V	
On Resistance, R_{ON}	120			Ω typ	$V_S = \pm 10\text{ V}$, $I_S = -10\text{ mA}$, see Figure 24
	190	230	260	Ω max	$V_{DD} = +13.5\text{ V}$, $V_{SS} = -13.5\text{ V}$
On-Resistance Match Between Channels, ΔR_{ON}	2.5			Ω typ	$V_S = \pm 10\text{ V}$, $I_S = -10\text{ mA}$
	6	10	11	Ω max	
On-Resistance Flatness, $R_{FLAT(ON)}$	20			Ω typ	$V_S = -5\text{ V}/0\text{ V}/+5\text{ V}$, $I_S = -10\text{ mA}$
	57	72	79	Ω max	
LEAKAGE CURRENTS					
Source Off Leakage, $I_{S(OFF)}$	± 0.02			nA typ	$V_{DD} = +16.5\text{ V}$, $V_{SS} = -16.5\text{ V}$ $V_S = \pm 10\text{ V}$, $V_D = \mp 10\text{ V}$, see Figure 27
	± 0.1	± 0.6	± 1	nA max	
Drain Off Leakage, $I_{D(OFF)}$	± 0.02			nA typ	$V_S = \pm 10\text{ V}$, $V_D = \mp 10\text{ V}$, see Figure 27
	± 0.1	± 0.6	± 1	nA max	
Channel On Leakage, $I_{D(ON)}$, $I_{S(ON)}$	± 0.02			nA typ	$V_S = V_D = \pm 10\text{ V}$, see Figure 23
	± 0.1	± 0.6	± 1	nA max	
DIGITAL OUTPUT					
Output Voltage					
Low, V_{OL}			0.4	V max	$I_{SINK} = 5\text{ mA}$
			0.2	V max	$I_{SINK} = 1\text{ mA}$
High or Low Output Current, I_{OL} or I_{OH}	0.001			μA typ	Output voltage (V_{OUT}) = ground voltage (V_{GND}) or V_L
			± 0.1	μA max	
Digital Output Capacitance, C_{OUT}	4			pF typ	
DIGITAL INPUTS					
Input Voltage					
High, V_{INH}			2	V min	$3.3\text{ V} < V_L \leq 5.5\text{ V}$
			1.35	V min	$2.7\text{ V} \leq V_L \leq 3.3\text{ V}$
Low, V_{INL}			0.8	V max	$3.3\text{ V} < V_L \leq 5.5\text{ V}$
			0.8	V max	$2.7\text{ V} \leq V_L \leq 3.3\text{ V}$
Low or High Input Current, I_{INL} or I_{INH}	0.001			μA typ	$V_{IN} = V_{GND}$ or V_L
			± 0.1	μA max	
Digital Input Capacitance, C_{IN}	4			pF typ	
DYNAMIC CHARACTERISTICS¹					
On Time, t_{ON}	375			ns typ	Load resistance (R_L) = $300\ \Omega$, load capacitance (C_L) = 35 pF
	450	450	450	ns max	$V_S = 10\text{ V}$, see Figure 32
Off Time, t_{OFF}	125			ns typ	$R_L = 300\ \Omega$, $C_L = 35\text{ pF}$
	160	180	205	ns max	$V_S = 10\text{ V}$, see Figure 32
Break-Before-Make Time Delay, t_D	205			ns typ	$R_L = 300\ \Omega$, $C_L = 35\text{ pF}$
			150	ns min	$V_{S1} = V_{S2} = 10\text{ V}$, see Figure 31
Charge Injection, Q_{INJ}	-0.9			pC typ	$V_S = 0\text{ V}$, source resistance (R_S) = $0\ \Omega$, $C_L = 1\text{ nF}$, see Figure 33
Off Isolation	-80			dB typ	$R_L = 50\ \Omega$, $C_L = 5\text{ pF}$, $f = 1\text{ MHz}$, see Figure 26

Parameter	+25°C	-40°C to +85°C	-40°C to +125°C	Unit	Test Conditions/Comments
Channel to Channel Crosstalk	-110			dB typ	$R_L = 50 \Omega$, $C_L = 5 \text{ pF}$, $f = 1 \text{ MHz}$, see Figure 25
Total Harmonic Distortion + Noise	0.15			% typ	$R_L = 10 \text{ k}\Omega$, 5 V rms, $f = 20 \text{ Hz}$ to 20 kHz, see Figure 28
-3 dB Bandwidth	1000			MHz typ	$R_L = 50 \Omega$, $C_L = 5 \text{ pF}$, see Figure 29
Insertion Loss	-6.5			dB typ	$R_L = 50 \Omega$, $C_L = 5 \text{ pF}$, $f = 1 \text{ MHz}$, see Figure 29
Off Switch Source Capacitance, $C_{S(OFF)}$	0.9			pF typ	$V_S = 0 \text{ V}$, $f = 1 \text{ MHz}$
	1.1			pF max	$V_S = 0 \text{ V}$, $f = 1 \text{ MHz}$
Off Switch Drain Capacitance, $C_{D(OFF)}$	1			pF typ	$V_S = 0 \text{ V}$, $f = 1 \text{ MHz}$
	1.2			pF max	$V_S = 0 \text{ V}$, $f = 1 \text{ MHz}$
On Switch Capacitances, $C_{D(ON)}$, $C_{S(ON)}$	2.6			pF typ	$V_S = 0 \text{ V}$, $f = 1 \text{ MHz}$
	3			pF max	$V_S = 0 \text{ V}$, $f = 1 \text{ MHz}$
POWER REQUIREMENTS					
Positive Power Supply Current, I_{DD}	0.001			μA typ	$V_{DD} = +16.5 \text{ V}$, $V_{SS} = -16.5 \text{ V}$ All switches open
			1.0	μA max	All switches open
	250			μA typ	All switches closed, $V_L = 5.5 \text{ V}$
			420	μA max	All switches closed, $V_L = 5.5 \text{ V}$
	260			μA typ	All switches closed, $V_L = 2.7 \text{ V}$
			440	μA max	All switches closed, $V_L = 2.7 \text{ V}$
Load Current, I_L					
Inactive	6.3			μA typ	Digital inputs = 0 V or V_L
			8.0	μA max	Digital inputs = 0 V or V_L
SCLK = 1 MHz	14			μA typ	\overline{CS} and SDI = 0 V or V_L , $V_L = 5 \text{ V}$
	7			μA typ	\overline{CS} and SDI = 0 V or V_L , $V_L = 3 \text{ V}$
SCLK = 50 MHz	390			μA typ	$\overline{CS} = V_L$ and SDI = 0 V or V_L , $V_L = 5 \text{ V}$
	210			μA typ	$\overline{CS} = V_L$ and SDI = 0 V or V_L , $V_L = 3 \text{ V}$
SDI = 1 MHz	15			μA typ	\overline{CS} and SCLK = 0 V or V_L , $V_L = 5 \text{ V}$
	7.5			μA typ	\overline{CS} and SCLK = 0 V or V_L , $V_L = 3 \text{ V}$
SDI = 25 MHz	230			μA typ	\overline{CS} and SCLK = 0 V or V_L , $V_L = 5 \text{ V}$
	120			μA typ	\overline{CS} and SCLK = 0 V or V_L , $V_L = 3 \text{ V}$
Active at 50 MHz SCLK	1.8			mA typ	Digital inputs toggle between 0 V and V_L , $V_L = 5.5 \text{ V}$
			2.1	mA max	Digital inputs toggle between 0 V and V_L , $V_L = 5.5 \text{ V}$
	0.7			mA typ	Digital inputs toggle between 0 V and V_L , $V_L = 2.7 \text{ V}$
Negative Power Supply Current, I_{SS}	0.001			mA max	Digital inputs = 0 V or V_L
			1.0	μA typ	Digital inputs = 0 V or V_L
			1.0	μA max	Digital inputs = 0 V or V_L
V_{DD}/V_{SS}			$\pm 4.5/\pm 16.5$	V min/V max	GND = 0 V

¹ Guaranteed by design; not subject to production test.

12 V SINGLE SUPPLY

$V_{DD} = 12\text{ V} \pm 10\%$, $V_{SS} = 0\text{ V}$, $V_L = 2.7\text{ V}$ to 5.5 V , and $GND = 0\text{ V}$, unless otherwise noted.

Table 2.

Parameter	+25°C	-40°C to +85°C	-40°C to +125°C	Unit	Test Conditions/Comments
ANALOG SWITCH					
Analog Signal Range			0V to V_{DD}	V	
On Resistance, R_{ON}	300			Ω typ	$V_S = 0\text{ V}$ to 10 V , $I_S = -1\text{ mA}$, see Figure 24
	475	567	625	Ω max	$V_{DD} = 10.8\text{ V}$, $V_{SS} = 0\text{ V}$
On-Resistance Match Between Channels, ΔR_{ON}	4.5			Ω typ	$V_S = 0\text{ V}$ to 10 V , $I_S = -1\text{ mA}$
	12	26	27	Ω max	
On-Resistance Flatness, $R_{FLAT(ON)}$	60			Ω typ	$V_S = 3\text{ V}/6\text{ V}/9\text{ V}$, $I_S = -1\text{ mA}$
LEAKAGE CURRENTS					
Source Off Leakage, $I_{S(OFF)}$	± 0.02			nA typ	$V_{DD} = 13.2\text{ V}$, $V_{SS} = 0\text{ V}$ $V_S = 1\text{ V}/10\text{ V}$, $V_D = 10\text{ V}/1\text{ V}$, see Figure 27
	± 0.1	± 0.6	± 1	nA max	
Drain Off Leakage, $I_{D(OFF)}$	± 0.02			nA typ	$V_S = 1\text{ V}/10\text{ V}$, $V_D = 10\text{ V}/1\text{ V}$, see Figure 27
	± 0.1	± 0.6	± 1	nA max	
Channel On Leakage, $I_{D(ON)}$, $I_{S(ON)}$	± 0.02			nA typ	$V_S = V_D = 1\text{ V}/10\text{ V}$, see Figure 23
	± 0.1	± 0.6	± 1	nA max	
DIGITAL OUTPUT					
Output Voltage Low, V_{OL}			0.4	V max	$I_{SINK} = 5\text{ mA}$
			0.2	V max	$I_{SINK} = 1\text{ mA}$
High or Low Output Current, I_{OL} or I_{OH}	0.001			μA typ	Output voltage (V_{OUT}) = ground voltage (V_{GND}) or V_L
			± 0.1	μA max	
Digital Output Capacitance, C_{OUT}	4			pF typ	
DIGITAL INPUTS					
Input Voltage High, V_{INH}			2	V min	$3.3\text{ V} < V_L \leq 5.5\text{ V}$
			1.35	V min	$2.7\text{ V} \leq V_L \leq 3.3\text{ V}$
Low, V_{INL}			0.8	V max	$3.3\text{ V} < V_L \leq 5.5\text{ V}$
			0.8	V max	$2.7\text{ V} \leq V_L \leq 3.3\text{ V}$
Low or High Input Current, I_{INL} or I_{INH}	0.001			μA typ	$V_{IN} = V_{GND}$ or V_L
			± 0.1	μA max	
Digital Input Capacitance, C_{IN}	4			pF typ	
DYNAMIC CHARACTERISTICS¹					
On Time, t_{ON}	395			ns typ	Load resistance (R_L) = $300\ \Omega$, load capacitance (C_L) = 35 pF
	475	485	490	ns max	$V_S = 8\text{ V}$, see Figure 32
Off Time, t_{OFF}	135			ns typ	$R_L = 300\ \Omega$, $C_L = 35\text{ pF}$
	170	195	225	ns max	$V_S = 8\text{ V}$, see Figure 32
Break-Before-Make Time Delay, t_D	230			ns typ	$R_L = 300\ \Omega$, $C_L = 35\text{ pF}$
			170	ns min	$V_{S1} = V_{S2} = 8\text{ V}$, see Figure 31
Charge Injection, Q_{INJ}	-0.5			pC typ	$V_S = 6\text{ V}$, $R_S = 0\ \Omega$, $C_L = 1\text{ nF}$, see Figure 33
Off Isolation	-80			dB typ	$R_L = 50\ \Omega$, $C_L = 5\text{ pF}$, $f = 1\text{ MHz}$, see Figure 26
Channel to Channel Crosstalk	-110			dB typ	$R_L = 50\ \Omega$, $C_L = 5\text{ pF}$, $f = 1\text{ MHz}$, see Figure 25
-3 dB Bandwidth	900			MHz typ	$R_L = 50\ \Omega$, $C_L = 5\text{ pF}$, see Figure 29

Parameter	+25°C	−40°C to +85°C	−40°C to +125°C	Unit	Test Conditions/Comments
Insertion Loss	−8.9			dB typ	$R_L = 50 \Omega$, $C_L = 5 \text{ pF}$, $f = 1 \text{ MHz}$, see Figure 29
Off Switch Source Capacitance, $C_{S(OFF)}$	1.2			pF typ	$V_S = 6 \text{ V}$, $f = 1 \text{ MHz}$
	1.4			pF max	$V_S = 6 \text{ V}$, $f = 1 \text{ MHz}$
Off Switch Drain Capacitance, $C_{D(OFF)}$	1.3			pF typ	$V_S = 6 \text{ V}$, $f = 1 \text{ MHz}$
	1.5			pF max	$V_S = 6 \text{ V}$, $f = 1 \text{ MHz}$
On Switch Capacitances, $C_{D(ON)}$, $C_{S(ON)}$	3.2			pF typ	$V_S = 6 \text{ V}$, $f = 1 \text{ MHz}$
	3.9			pF max	$V_S = 6 \text{ V}$, $f = 1 \text{ MHz}$
POWER REQUIREMENTS					
Positive Power Supply Current, I_{DD}	0.001			μA typ	$V_{DD} = 13.2 \text{ V}$ All switches open
			1.0	μA max	All switches open
	220			μA typ	All switches closed, $V_L = 5.5 \text{ V}$
			380	μA max	All switches closed, $V_L = 5.5 \text{ V}$
	270			μA typ	All switches closed, $V_L = 2.7 \text{ V}$
			440	μA max	All switches closed, $V_L = 2.7 \text{ V}$
Load Current, I_L					
Inactive	6.3			μA typ	Digital inputs = 0 V or V_L
			8.0	μA max	Digital inputs = 0 V or V_L
SCLK = 1 MHz	14			μA typ	\overline{CS} and SDI = 0 V or V_L , $V_L = 5 \text{ V}$
	7			μA typ	\overline{CS} and SDI = 0 V or V_L , $V_L = 3 \text{ V}$
SCLK = 50 MHz	390			μA typ	$\overline{CS} = V_L$ and SDI = 0 V or V_L , $V_L = 5 \text{ V}$
	210			μA typ	$\overline{CS} = V_L$ and SDI = 0 V or V_L , $V_L = 3 \text{ V}$
SDI = 1 MHz	15			μA typ	\overline{CS} and SCLK = 0 V or V_L , $V_L = 5 \text{ V}$
	7.5			μA typ	\overline{CS} and SCLK = 0 V or V_L , $V_L = 3 \text{ V}$
SDI = 25 MHz	230			μA typ	\overline{CS} and SCLK = 0 V or V_L , $V_L = 5 \text{ V}$
	120			μA typ	\overline{CS} and SCLK = 0 V or V_L , $V_L = 3 \text{ V}$
Active at 50 MHz SCLK	1.8			mA typ	Digital inputs toggle between 0 V and V_L , $V_L = 5.5 \text{ V}$
			2.1	mA max	
	0.7			mA typ	Digital inputs toggle between 0 V and V_L , $V_L = 2.7 \text{ V}$
			1.0	mA max	
V_{DD}			5/16.5	V min/V max	$GND = 0 \text{ V}$, $V_{SS} = 0 \text{ V}$

¹ Guaranteed by design; not subject to production test.

CONTINUOUS CURRENT PER CHANNEL, S_x OR D_x

Table 3. Four Channels On

Parameter	25°C	85°C	125°C	Unit
CONTINUOUS CURRENT, S_x OR D_x ¹				
$V_{DD} = 15 \text{ V}$, $V_{SS} = -15 \text{ V}$ ($\theta_{JA} = 67^\circ\text{C/W}$)	20	8	2.5	mA maximum
$V_{DD} = 12 \text{ V}$, $V_{SS} = 0 \text{ V}$ ($\theta_{JA} = 67^\circ\text{C/W}$)	14	6.67	2.4	mA maximum

¹ S_x refers to the S1 to S4 pins, and D_x refers to the D1 to D4 pins.

Table 4. One Channel On

Parameter	25°C	85°C	125°C	Unit
CONTINUOUS CURRENT, S_x OR D_x ¹				
$V_{DD} = 15 \text{ V}$, $V_{SS} = -15 \text{ V}$ ($\theta_{JA} = 67^\circ\text{C/W}$)	35	9.6	2.5	mA maximum
$V_{DD} = 12 \text{ V}$, $V_{SS} = 0 \text{ V}$ ($\theta_{JA} = 67^\circ\text{C/W}$)	24.7	8.77	2.5	mA maximum

¹ S_x refers to the S1 to S4 pins, and D_x refers to the D1 to D4 pins.

TIMING CHARACTERISTICS

$V_L = 2.7\text{ V}$ to 5.5 V , $GND = 0\text{ V}$, and all specifications T_{MIN} to T_{MAX} , unless otherwise noted. Guaranteed by design and characterization but not production tested.

Table 5.

Parameter	Limit	Unit	Test Conditions/Comments
TIMING CHARACTERISTICS			
t_1	20	ns min	SCLK period
t_2	8	ns min	SCLK high pulse width
t_3	8	ns min	SCLK low pulse width
t_4	10	ns min	\overline{CS} falling edge to SCLK active edge
t_5	6	ns min	Data setup time
t_6	8	ns min	Data hold time
t_7	10	ns min	SCLK active edge to \overline{CS} rising edge
t_8	20	ns max	\overline{CS} falling edge to SDO data available
t_9^1	20	ns max	SCLK falling edge to SDO data available
t_{10}	20	ns max	\overline{CS} rising edge to SDO returns to high impedance
t_{11}	20	ns min	\overline{CS} high time between SPI commands
t_{12}	8	ns min	\overline{CS} falling edge to SCLK becomes stable
t_{13}	8	ns min	\overline{CS} rising edge to SCLK becomes stable

¹ Measured with the 1 kΩ pull-up resistor to V_L and a 20 pF load. t_9 determines the maximum SCLK frequency when SDO is used.

Timing Diagrams

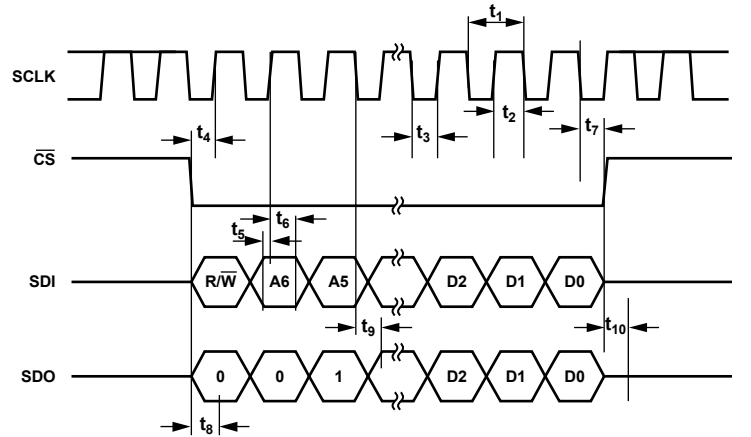
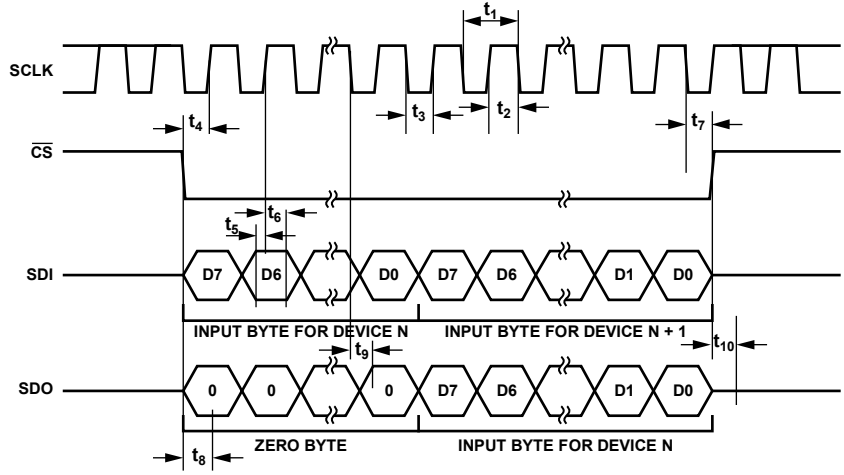
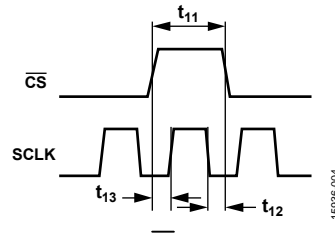

Figure 2. Address Mode Timing Diagram



15936-003

Figure 3. Daisy-Chain Timing Diagram



15936-004

Figure 4. SCLK/ \overline{CS} Timing Diagram

ABSOLUTE MAXIMUM RATINGS

$T_A = 25^\circ\text{C}$, unless otherwise noted.

Table 6.

Parameter	Rating
V_{DD} to V_{SS}	35 V
V_{DD} to GND	-0.3 V to +25 V
V_{SS} to GND	+0.3 V to -25 V
V_L to GND	-0.3 V to +6 V
Analog Inputs ¹	$V_{SS} - 0.3\text{ V}$ to $V_{DD} + 0.3\text{ V}$ or 30 mA, whichever occurs first
Digital Inputs ¹	-0.3 V to +6 V
Peak Current, Sx or Dx Pins ²	38 mA (pulsed at 1 ms, 10% duty cycle maximum)
Continuous Current, Sx or Dx Pins ^{2,3}	Data + 15%
Operating Temperature Range	-40°C to +125°C
Storage Temperature Range	-65°C to +150°C
Junction Temperature	150°C
Reflow Soldering Peak Temperature, Pb Free	260(+0/-5)°C

¹ Overvoltages at the digital Sx and Dx pins are clamped by internal diodes. Limit current to the maximum ratings given.

² Sx refers to the S1 to S4 pins, and Dx refers to the D1 to D4 pins.

³ See Table 3 and Table 4.

Stresses at or above those listed under Absolute Maximum Ratings may cause permanent damage to the product. This is a stress rating only; functional operation of the product at these or any other conditions above those indicated in the operational section of this specification is not implied. Operation beyond the maximum operating conditions for extended periods may affect product reliability.

Only one absolute maximum rating can be applied at any one time.

THERMAL RESISTANCE

Thermal performance is directly linked to printed circuit board (PCB) design and operating environment. Careful attention to PCB thermal design is required.

Table 7. Thermal Resistance

Package Type	θ_{JA}	θ_{JC}	Ψ_{JT}	Unit
CP-24-15 ¹	67	33.7	11.1	°C/W

¹ Thermal impedance simulated values are based on JEDEC 252P thermal test board with four thermal vias. See JEDEC JESD-51.

ESD CAUTION



ESD (electrostatic discharge) sensitive device. Charged devices and circuit boards can discharge without detection. Although this product features patented or proprietary protection circuitry, damage may occur on devices subjected to high energy ESD. Therefore, proper ESD precautions should be taken to avoid performance degradation or loss of functionality.

PIN CONFIGURATION AND FUNCTION DESCRIPTIONS

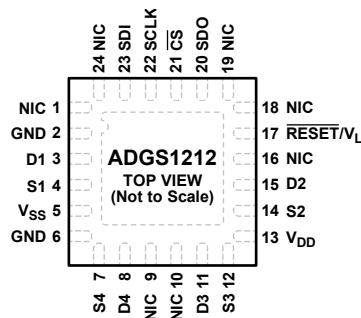

NOTES

1. THE EXPOSED PAD IS CONNECTED INTERNALLY. FOR INCREASED RELIABILITY OF THE SOLDER JOINTS AND MAXIMUM THERMAL CAPABILITY, IT IS RECOMMENDED THAT THE EXPOSED PAD BE SOLDERED TO THE SUBSTRATE, V_{SS} .
2. NIC = NOT INTERNALLY CONNECTED.

15938-005

Figure 5. Pin Configuration

Table 8. Pin Function Descriptions

Pin No.	Mnemonic	Description
1, 9, 10, 16, 18, 19, 24	NIC	Not Internally Connected.
2, 6	GND	Ground (0 V) Reference.
3	D1	Drain Terminal 1. This pin can be an input or output.
4	S1	Source Terminal 1. This pin can be an input or output.
5	V_{SS}	Most Negative Power Supply Potential. In single-supply applications, tie V_{SS} to GND.
7	S4	Source Terminal 4. This pin can be an input or output.
8	D4	Drain Terminal 4. This pin can be an input or output.
11	D3	Drain Terminal 3. This pin can be an input or output.
12	S3	Source Terminal 3. This pin can be an input or output.
13	V_{DD}	Most Positive Power Supply Potential.
14	S2	Source Terminal 2. This pin can be an input or output.
15	D2	Drain Terminal 2. This pin can be an input or output.
17	$\overline{\text{RESET}}/V_L$	$\overline{\text{RESET}}$ /Logic Power Supply Input (V_L). Under normal operation, drive the $\overline{\text{RESET}}/V_L$ pin with a 2.7 V to 5.5 V supply. Pull the $\overline{\text{RESET}}$ pin low to complete a hardware reset. After a reset, all switches open, and the appropriate registers are set to their default values.
20	SDO	Serial Data Output. This pin can be used for daisy chaining a number of devices together or for reading back the data stored in a register for diagnostic purposes. The serial data is propagated on the falling edge of SCLK. Pull this open-drain output to V_L with an external resistor.
21	$\overline{\text{CS}}$	Active Low Control Input. $\overline{\text{CS}}$ is the frame synchronization signal for the input data.
22	SCLK	Serial Clock Input. Data is captured on the positive edge of SCLK. Data can be transferred at rates of up to 50 MHz.
23	SDI	Serial Data Input. Data is captured on the positive edge of the serial clock input.
	EPAD	Exposed Pad. The exposed pad is connected internally. For increased reliability of the solder joints and maximum thermal capability, it is recommended that the exposed pad be soldered to the substrate, V_{SS} .

TYPICAL PERFORMANCE CHARACTERISTICS

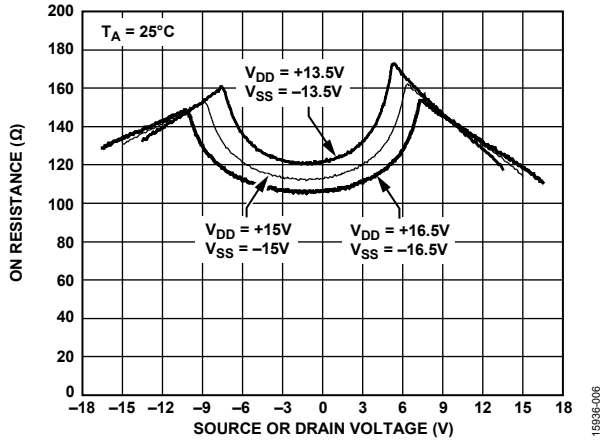

Figure 6. On Resistance vs. Source or Drain Voltage (V_S or V_D) for Various Dual Supplies

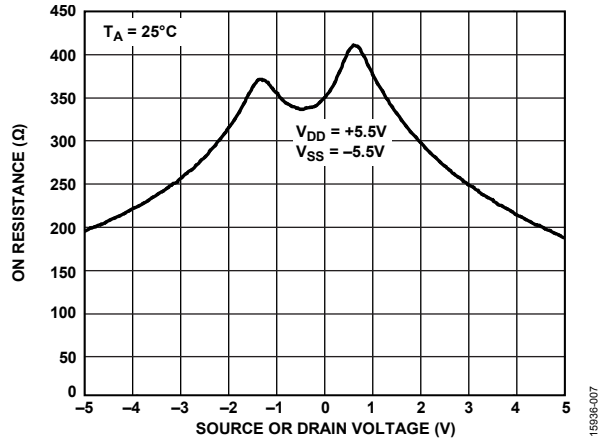

Figure 7. On Resistance vs. Source or Drain Voltage (V_S or V_D) for ± 5.5 V Dual Supply

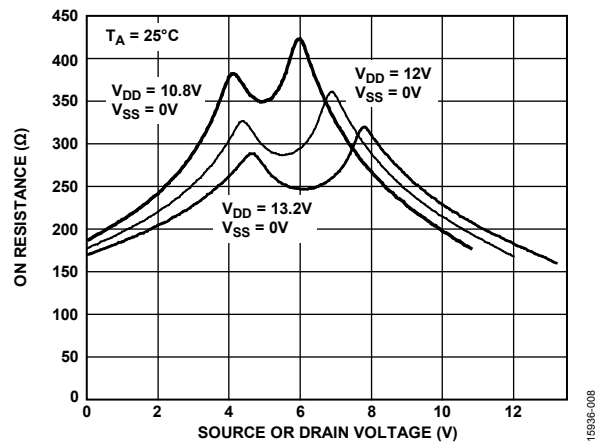

Figure 8. On Resistance vs. Source or Drain Voltage (V_S or V_D) for Various Single Supplies

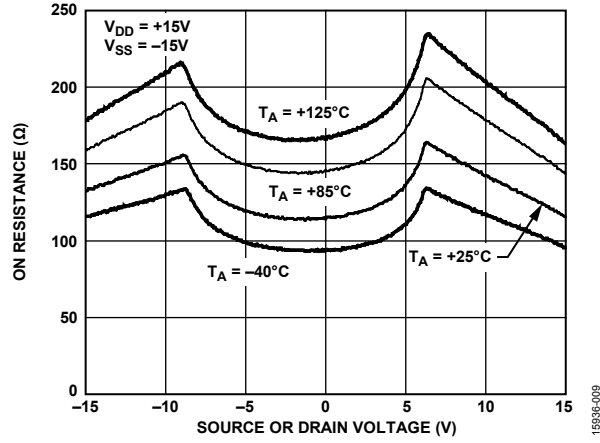

Figure 9. On Resistance vs. Source or Drain Voltage (V_S or V_D) for Various Ambient Temperatures (T_A), ± 15 V Dual Supply

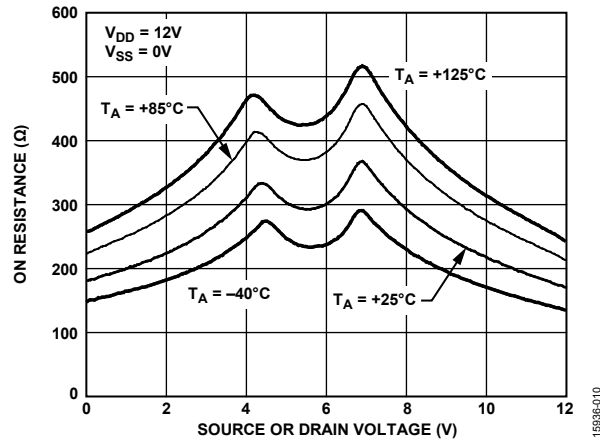

Figure 10. On Resistance vs. Source or Drain Voltage (V_S or V_D) for Ambient Temperatures (T_A), 12 V Single Supply

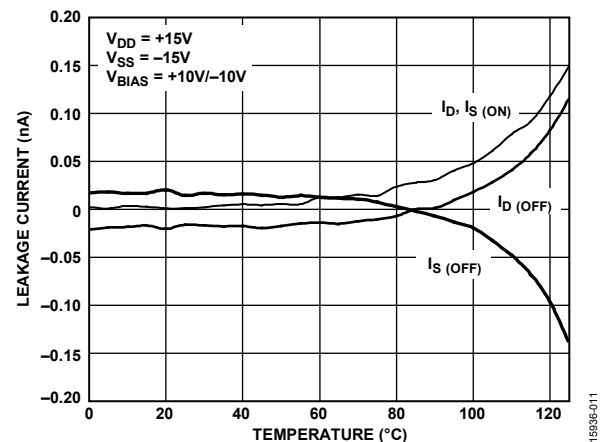

Figure 11. Leakage Current vs. Temperature, ± 15 V Dual Supply

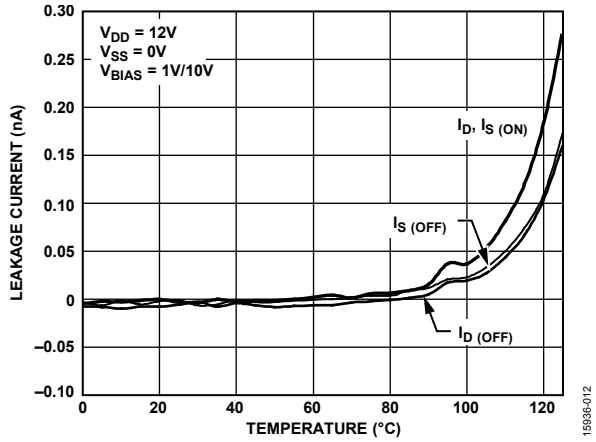

Figure 12. Leakage Current vs. Temperature, 12 V Single Supply

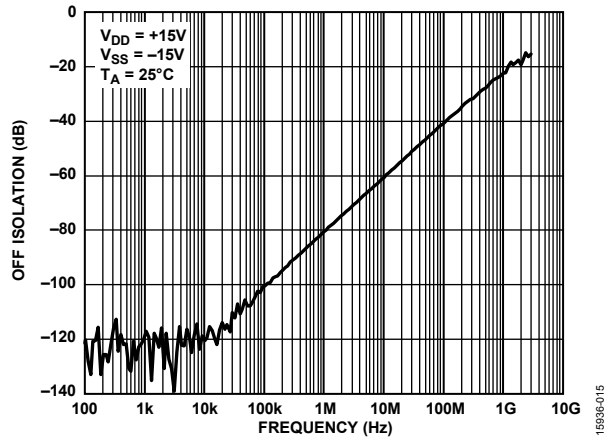

Figure 15. Off Isolation vs. Frequency, ±15 V Dual Supply

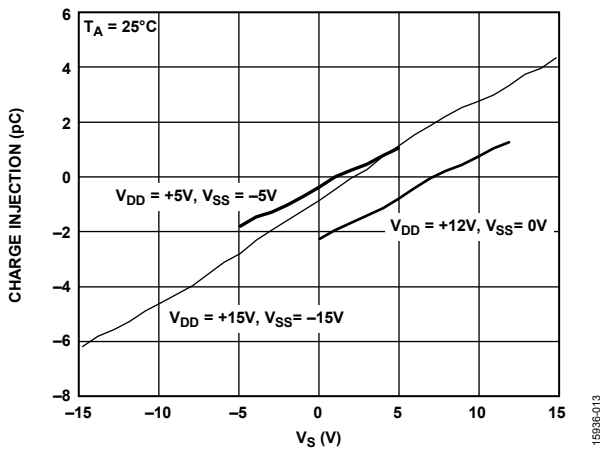

Figure 13. Charge Injection vs. Source Voltage (V_S)

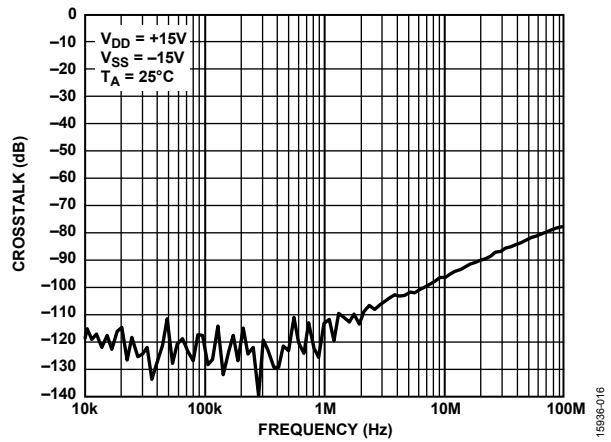

Figure 16. Crosstalk vs. Frequency, ±15 V Dual Supply

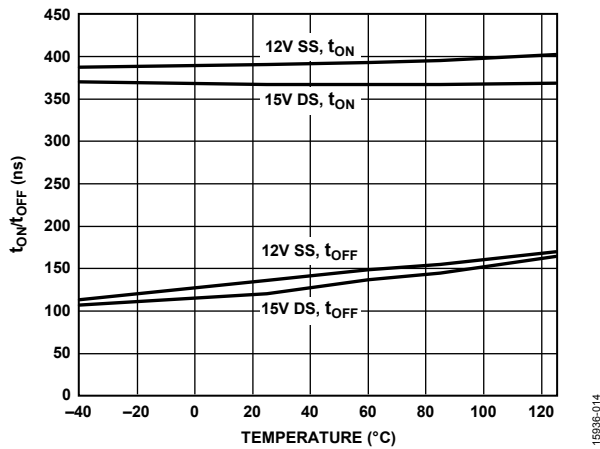

Figure 14. t_{ON}/t_{OFF} vs. Temperature for Single Supply (SS) and Dual Supply (DS)

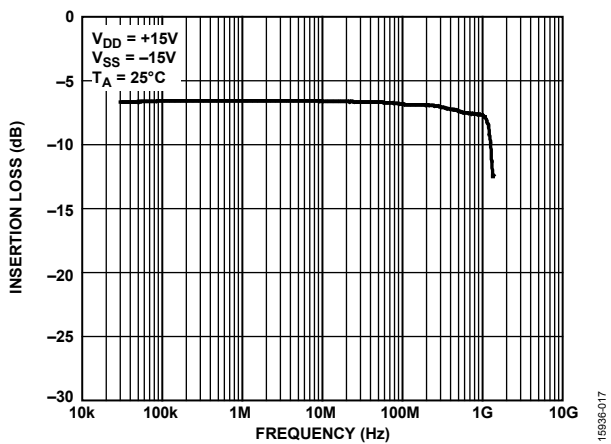

Figure 17. Insertion Loss vs. Frequency, ±15 V Dual Supply

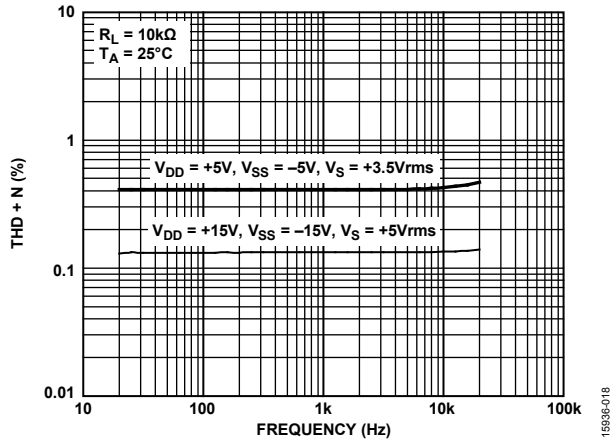

Figure 18. Total Harmonic Distortion Plus Noise (THD + N) vs. Frequency

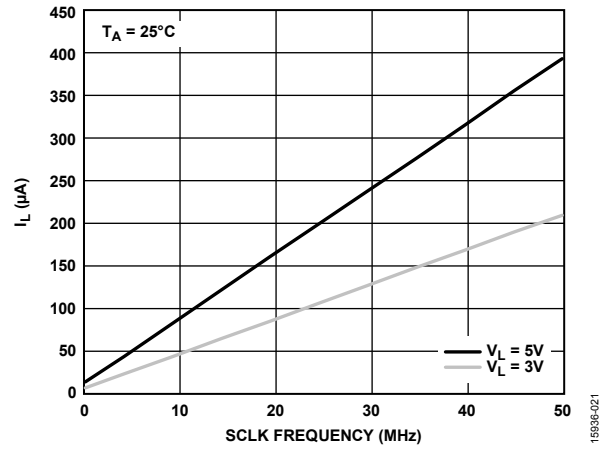

Figure 21. Load Current (I_L) vs. SCLK Frequency when \overline{CS} High

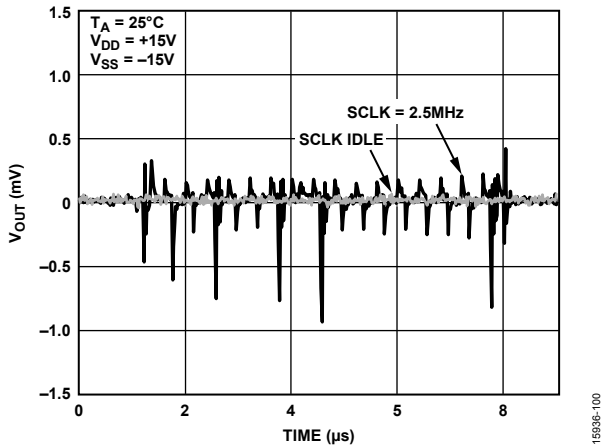

Figure 19. Digital Feedthrough

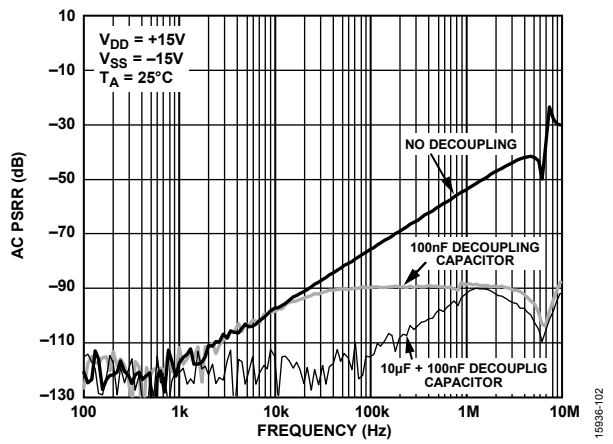

Figure 22. AC Power Supply Rejection Ratio (PSRR) vs. Frequency

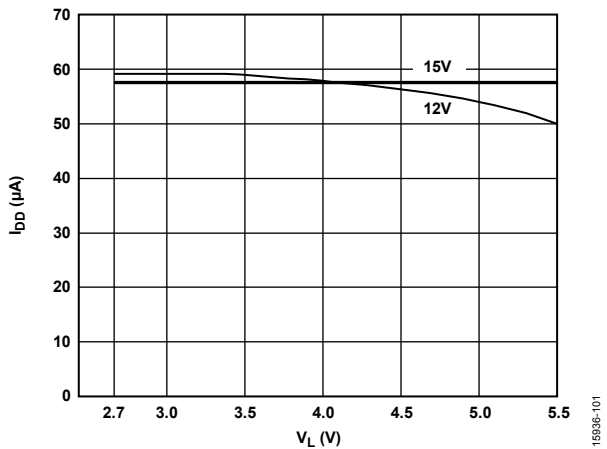

Figure 20. Positive Power Supply Current (I_{BD}) vs. V_L

TEST CIRCUITS

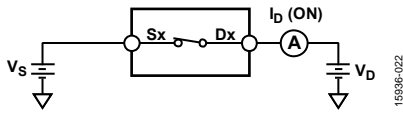

Figure 23. On Leakage

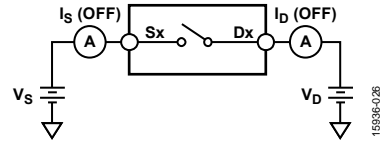

Figure 27. Off Leakage

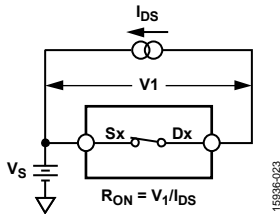

Figure 24. On Resistance

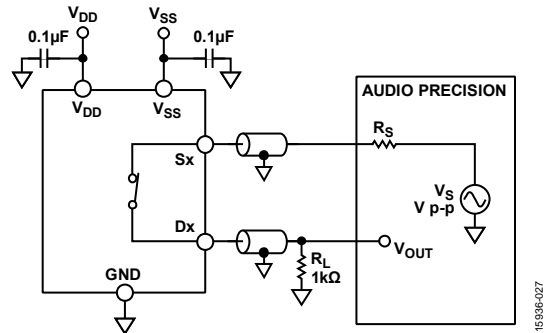
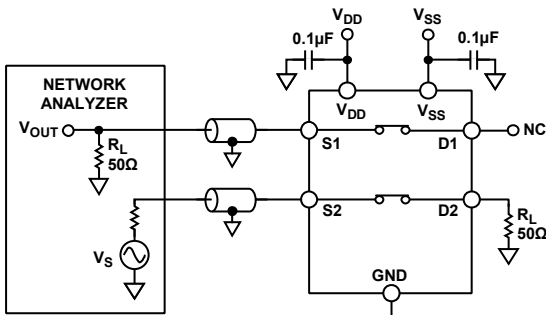
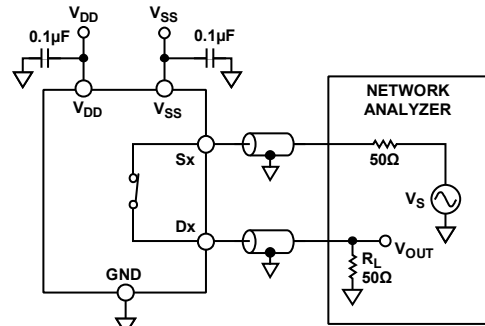

Figure 28. THD + Noise



CHANNEL TO CHANNEL CROSSTALK = $20 \log \frac{V_{OUT}}{V_S}$

Figure 25. Channel to Channel Crosstalk



INSERTION LOSS = $20 \log \frac{V_{OUT} \text{ WITH SWITCH}}{V_S \text{ WITHOUT SWITCH}}$

Figure 29. -3 dB Bandwidth

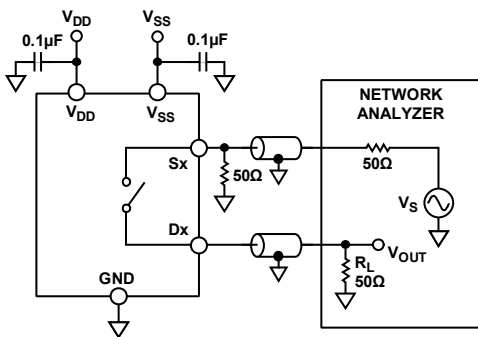

OFF ISOLATION = $20 \log \frac{V_{OUT}}{V_S}$

Figure 26. Off Isolation

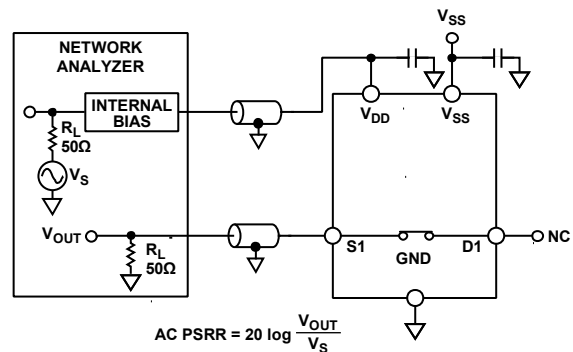

AC PSRR = $20 \log \frac{V_{OUT}}{V_S}$

Figure 30. AC PSRR

NOTES
1. BOARD AND COMPONENT EFFECTS ARE NOT DE-EMBEDDED FROM THE AC PSRR MEASUREMENT.

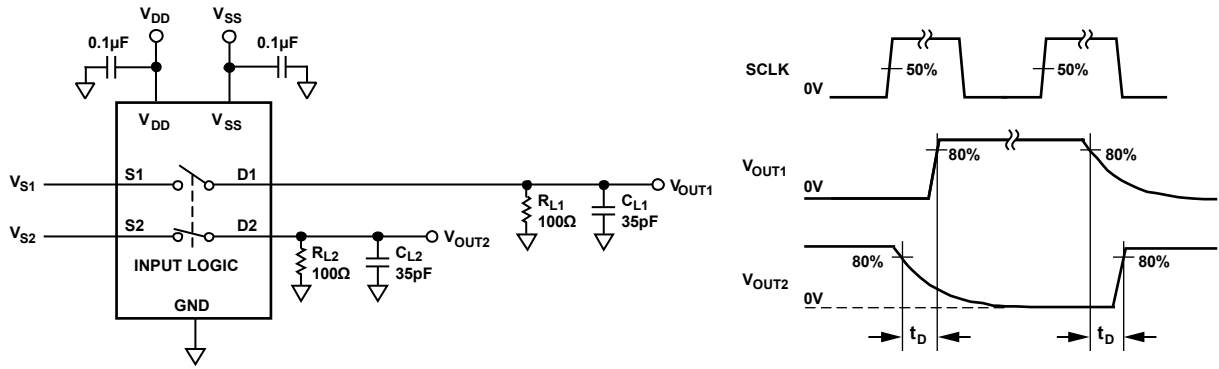

Figure 31. Break-Before-Make Time Delay, t_D

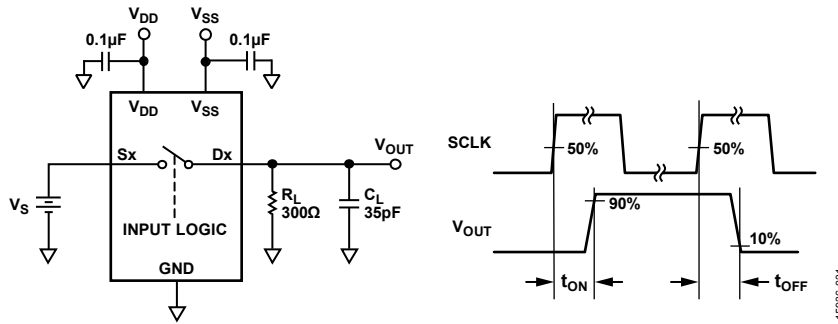

Figure 32. Switching Times, t_{ON} and t_{OFF}

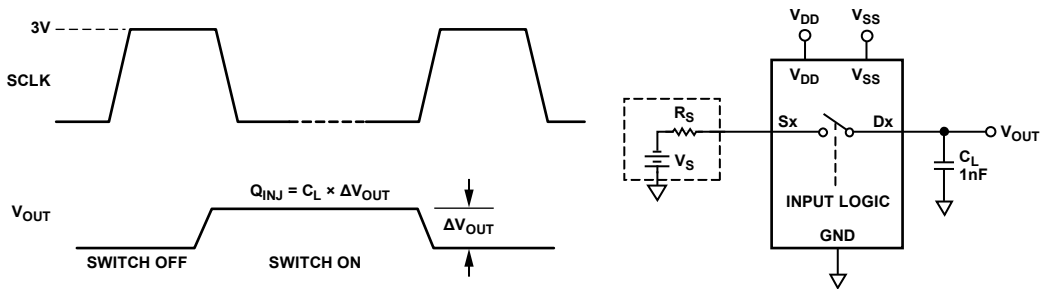

Figure 33. Charge Injection, Q_{INJ}

TERMINOLOGY

I_{DD}

I_{DD} is the positive supply current.

I_{SS}

I_{SS} is the negative supply current.

V_D, V_S

V_D and V_S are the analog voltage on Terminal Dx and Terminal Sx, respectively.

R_{ON}

R_{ON} is the ohmic resistance between Terminal Dx and Terminal Sx.

ΔR_{ON}

ΔR_{ON} represents the difference between the R_{ON} of any two channels.

$R_{FLAT(ON)}$

$R_{FLAT(ON)}$ is defined as the difference between the maximum and minimum value of on resistance measured over the specified analog signal range.

$I_S(OFF)$

$I_S(OFF)$ is the source leakage current with the switch off.

$I_D(OFF)$

$I_D(OFF)$ is the drain leakage current with the switch off.

$I_D(ON), I_S(ON)$

$I_D(ON)$ and $I_S(ON)$ are the channel leakage currents with the switch on.

V_{INL}

V_{INL} is the maximum input voltage for Logic 0.

V_{INH}

V_{INH} is the minimum input voltage for Logic 1.

I_{INL}, I_{INH}

I_{INL} and I_{INH} are the low and high input currents of the digital inputs, respectively.

$C_D(OFF)$

$C_D(OFF)$ is the off switch drain capacitance, which is measured with reference to ground.

$C_S(OFF)$

$C_S(OFF)$ is the off switch source capacitance, which is measured with reference to ground.

$C_D(ON), C_S(ON)$

$C_D(ON)$ and $C_S(ON)$ are the on switch capacitances, which are measured with reference to ground.

C_{IN}

C_{IN} is the digital input capacitance.

t_{ON}

t_{ON} is the delay between applying the digital control input and the output switching on.

t_{OFF}

t_{OFF} is the delay between applying the digital control input and the output switching off.

Off Isolation

Off isolation is a measure of unwanted signal coupling through an off switch.

Charge Injection

Charge injection is a measure of the glitch impulse transferred from the digital input to the analog output during switching.

Crosstalk

Crosstalk is a measure of unwanted signal that is coupled through from one channel to another as a result of parasitic capacitance.

-3 dB Bandwidth

Bandwidth is the frequency at which the output is attenuated by 3 dB.

On Response

On response is the frequency response of the on switch.

Insertion Loss

Insertion loss is the loss due to the on resistance of the switch.

Total Harmonic Distortion Plus Noise (THD + N)

THD + N is the ratio of the harmonic amplitude plus noise of the signal to the fundamental.

AC Power Supply Rejection Ratio (AC PSRR)

AC PSRR is the ratio of the amplitude of signal on the output to the amplitude of the modulation. AC PSRR is a measure of the ability of the device to avoid coupling noise and spurious signals that appear on the supply voltage pin to the output of the switch. The dc voltage on the device is modulated by a sine wave of 0.62 V p-p.

THEORY OF OPERATION

The ADGS1212 is a set of serially controlled, quad SPST switches with error detection features. SPI Mode 0 and SPI Mode 3 can be used with the device, and it operates with SCLK frequencies up to 50 MHz. The default mode for the ADGS1212 is address mode in which the registers of the device are accessed by a 16-bit SPI command that is bounded by \overline{CS} . The SPI command becomes 24 bit if the user enables CRC error detection. Other error detection features include SCLK count error and invalid read/write error. If any of these SPI interface errors occur, they are detectable by reading the error flags register. The ADGS1212 can also operate in two other modes: burst mode and daisy-chain mode.

The interface pins of the ADGS1212 are \overline{CS} , SCLK, SDI, and SDO. Hold \overline{CS} low when using the SPI interface. Data is captured on SDI on the rising edge of SCLK, and data is propagated out on SDO on the falling edge of SCLK. SDO has an open-drain output; thus, connect a pull-up to this output. When not pulled low by the ADGS1212, SDO is in a high impedance state.

ADDRESS MODE

Address mode is the default mode for the ADGS1212 on power up. A single SPI frame in address mode is bounded by a \overline{CS} falling edge and the succeeding \overline{CS} rising edge. It is comprised of 16 SCLK cycles. The timing diagram for address mode is shown in Figure 34. The first SDI bit indicates if the SPI command is a read or write command. When the first bit is set to 0, a write command is issued, and if the first bit is set to 1, a read command is issued. The next seven bits determine the target register address. The remaining eight bits provide the data to the addressed register. The last eight bits are ignored during a read command, because during these clock cycles, SDO propagates out the data contained in the addressed register.

The target register address of an SPI command is determined on the eighth SCLK rising edge. Data from this register propagates out on SDO from the 9th to the 16th SCLK falling edge during SPI

reads. A register write occurs on the 16th SCLK rising edge during SPI writes.

During any SPI command, SDO sends out eight alignment bits on the first eight SCLK falling edges. The alignment bits observed at SDO are 0x25 by default.

ERROR DETECTION FEATURES

Protocol and communication errors on the SPI interface are detectable. There are three detectable errors: incorrect SCLK count error detection, invalid read and write address error detection, and CRC error detection. Each of these errors has a corresponding enable bit in the error configuration register. In addition, there is an error flag bit for each of these errors in the error flags register.

Cyclic Redundancy Check (CRC) Error Detection

The CRC error detection feature extends a valid SPI frame by 8 SCLK cycles. These eight extra cycles are needed to send the CRC byte for that SPI frame. The CRC byte is calculated by the SPI block using the 16-bit payload: the R/W A bit, Register Address Bits[6:0], and Register Data Bits[7:0]. The CRC polynomial used in the SPI block is $x^8 + x^2 + x^1 + 1$ with a seed value of 0. For a timing diagram with CRC enabled, see Figure 35. Register writes occur at the 24th SCLK rising edge with CRC error checking enabled.

During a SPI write, the microcontroller/central processing unit (CPU) provides the CRC byte through SDI. The SPI block checks the CRC byte just before the 24th SCLK rising edge. On this same edge, the register write is prevented if an incorrect CRC byte is received by the SPI interface. The CRC error flag is asserted in the error flags register in the case of the incorrect CRC byte being detected.

During a SPI read, the CRC byte is provided to the microcontroller through SDO.

The CRC error detection feature is disabled by default and can be configured by the user through the error configuration register.

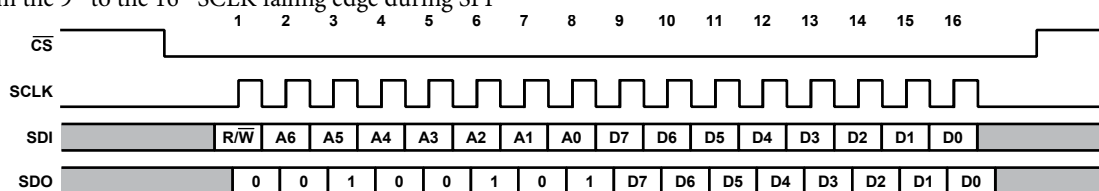

Figure 34. Address Mode Timing Diagram

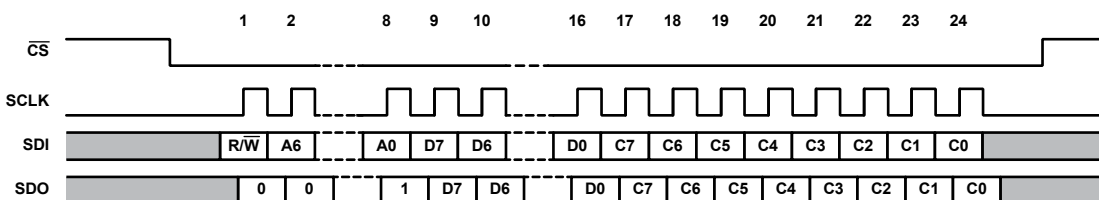

Figure 35. Timing Diagram with CRC Enabled

SCLK Count Error Detection

SCLK count error detection allows the user to detect if an incorrect number of SCLK cycles are sent by the microcontroller/CPU. When in address mode, with CRC disabled, 16 SCLK cycles are expected. If 16 SCLK cycles are not detected, the SCLK count error flag asserts in the error flags register. When less than 16 SCLK cycles are received by the device, a write to the register map never occurs. When the ADGS1212 receives more than 16 SCLK cycles, a write to the memory map still occurs at the 16th SCLK rising edge, and the flag asserts in the error flags register. With CRC enabled, the expected number of SCLK cycles becomes 24. SCLK count error detection is enabled by default and can be configured by the user through the error configuration register.

Invalid Read/Write Address Error

An invalid read/write address error detects when a nonexistent register address is a target for a read or write. In addition, this error asserts when a write to a read only register is attempted. The invalid read/write address error flag asserts in the error flags register when an invalid read/write address error occurs. The invalid read/write address error is detected on the ninth SCLK rising edge, which means a write to the register never occurs when an invalid address is targeted. Invalid read/write address error detection is enabled by default and can be disabled by the user through the error configuration register.

CLEARING THE ERROR FLAGS REGISTER

To clear the error flags register, write the special 16-bit SPI frame, 0x6CA9, to the device. This SPI command does not trigger the invalid R/W address error. When CRC is enabled, the user must also send the correct CRC byte for a successful error clear command. At the 16th or 24th SCLK rising edge, the error flags register resets to zero.

BURST MODE

The SPI interface can accept consecutive SPI commands without the need to deassert the CS line, which is called burst mode. Burst mode is enabled through the burst enable register. This mode uses the same 16-bit command to communicate with the device. In addition, the response of the device at SDO is still aligned with the corresponding SPI command. Figure 36 shows an example of SDI and SDO during burst mode.

The invalid read/write address and CRC error checking functions operate similarly during burst mode as they do during address mode. However, SCLK count error detection operates in a slightly different manner. The total number of SCLK cycles within a given CS frame are counted, and if the total is not a multiple of 16, or a multiple of 24 when CRC is enabled, the SCLK count error flag asserts.

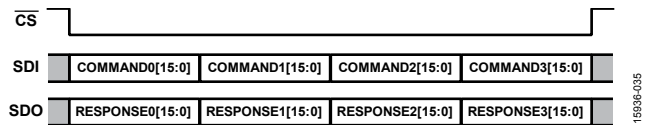

Figure 36. Burst Mode Frame

SOFTWARE RESET

When in address mode, the user can initiate a software reset. To do so, write two consecutive SPI commands, 0xA3 followed by 0x05, targeting Register 0x0B. After a software reset, all register values are set to default.

DAISY-CHAIN MODE

The connection of several ADGS1212 devices in a daisy-chain configuration is possible, and Figure 37 shows this setup. All devices share the same CS and SCLK line, whereas the SDO line of a device forms a connection to the SDI line of the next device, creating a shift register. In daisy-chain mode, SDO is an eight cycle delayed version of SDI. When in daisy-chain mode, all commands target the switch data register. Therefore, it is not possible to make configuration changes while in daisy-chain mode.

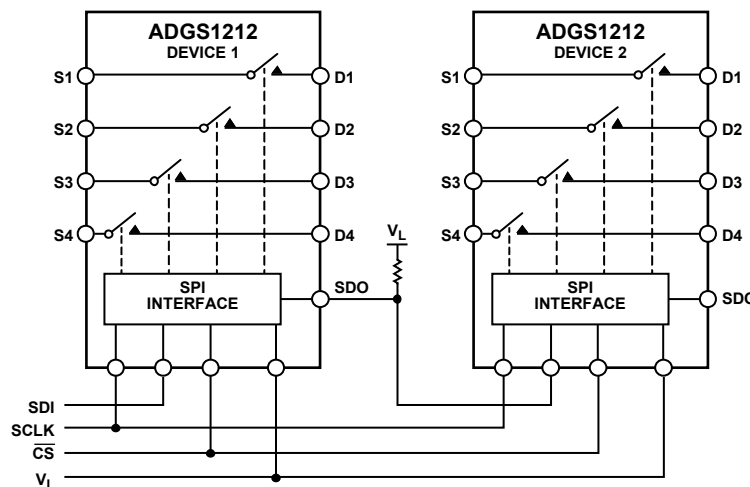

Figure 37. Two ADGS1212 Devices Connected in a Daisy-Chain Configuration

The ADGS1212 can only enter daisy-chain mode when in address mode by sending the 16-bit SPI command, 0x2500 (see Figure 38). When the ADGS1212 receives this command, the SDO of the device sends out the same command because the alignment bits at SDO are 0x25, which allows multiple daisy-connected devices to enter daisy-chain mode in a single SPI frame. A hardware reset is required to exit daisy-chain mode.

For the timing diagram of a typical daisy-chain SPI frame, see Figure 39. When CS goes high, Device 1 writes Command 0, Bits[7:0] to its switch data register, Device 2 writes Command 1, Bits[7:0] to its switches, and so on. The SPI block uses the last eight bits it received through SDI to update the switches. After entering daisy-chain mode, the first eight bits sent out by SDO on each device in the chain are 0x00. When CS goes high, the internal shift register value does not reset back to zero.

An SCLK rising edge reads in data on SDI while data is propagated out by SDO on an SCLK falling edge. The expected number of SCLK cycles must be a multiple of eight before CS goes high. When this is not the case, the SPI interface sends the last eight bits received to the switch data register.

POWER-ON RESET

The digital section of the ADGS1212 goes through an initialization phase during V_L power up. This initialization also occurs after a hardware or software reset. After V_L power-up or a reset, ensure that a minimum of 120 μs from the time of power-up or reset before any SPI command is issued. Ensure that V_L does not drop out during the 120 μs initialization phase because this may result in incorrect operation of the ADGS1212.

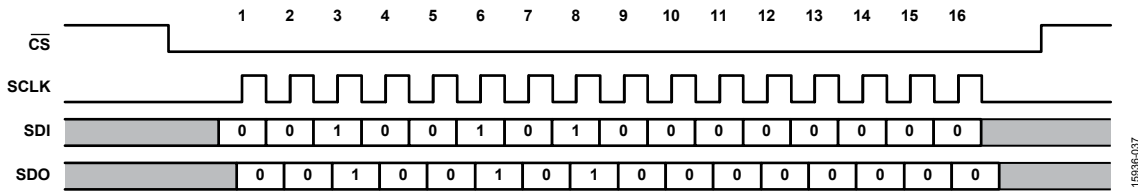
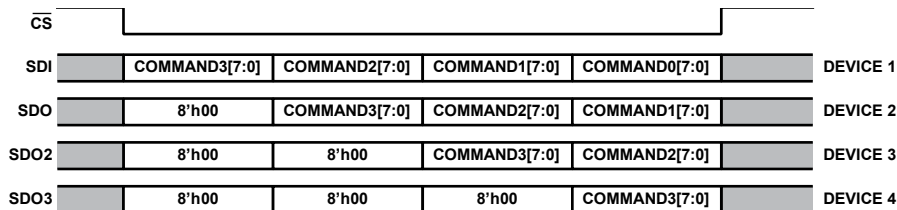

Figure 38. SPI Command to Enter Daisy-Chain Mode



NOTES
 1. SDO2 AND SDO3 ARE THE OUTPUT COMMANDS FROM DEVICE 2 AND DEVICE 3, RESPECTIVELY.

Figure 39. Example of a SPI Frame Where Four ADGS1212 Devices Connect in Daisy-Chain Mode

APPLICATIONS INFORMATION

BREAK-BEFORE-MAKE SWITCHING

The ADGS1212 exhibits break-before-make switching. This feature allows the use of the device in multiplexer applications. Using the device like a multiplexer can be accomplished by externally hardwiring the device into the desired mux configuration, as shown in Figure 40.

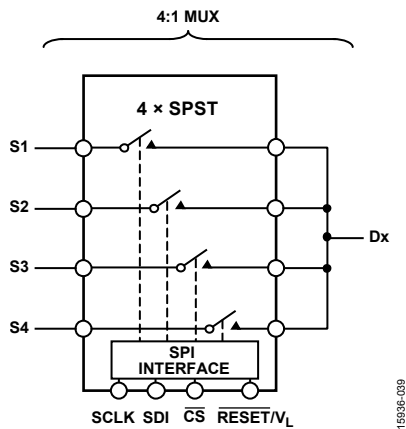

Figure 40. A SPI Controlled Switch Configured into a 4:1 Mux

POWER SUPPLY RAILS

To guarantee correct operation of the ADGS1212, 0.1 μF decoupling capacitors are required.

The ADGS1212 can operate with bipolar supplies between $\pm 4.5\text{ V}$ and $\pm 16.5\text{ V}$. The supplies on V_{DD} and V_{SS} do not have to be symmetrical; however, the V_{DD} to V_{SS} range must not exceed 33 V. The ADGS1212 can also operate with single supplies between 5 V and 16.5 V with V_{SS} connected to GND.

The voltage range that can be supplied to V_{I} is from 2.7 V to 5.5 V.

The device is fully specified at $\pm 15\text{ V}$ and $+12\text{ V}$ analog supply voltage ranges.

POWER SUPPLY RECOMMENDATIONS

Analog Devices, Inc., has a wide range of power management products to meet the requirements of most high performance signal chains.

An example of a bipolar power solution is shown in Figure 41. The ADP5070 (dual switching regulator) generates a positive and negative supply rail for the ADGS1212, amplifier, and/or a precision converter in a typical signal chain. Also shown in Figure 41 are two optional low dropout (LDO) regulators (ADP7118 and ADP7182 positive and negative LDOs respectively) that can be used to reduce the output ripple of the ADP5070 in ultralow noise sensitive applications.

The ADM7160 can be used to generate the V_{I} voltage that is required to power digital circuitry within the ADGS1212.

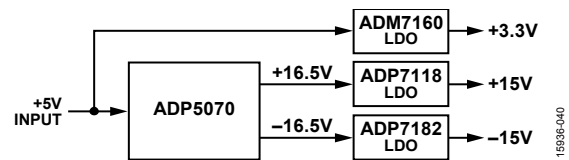

Figure 41. Bipolar Power Solution

Table 9. Recommended Power Management Devices

Product	Description
ADP5070	1 A/0.6 A, dc-to-dc switching regulator with independent positive and negative outputs
ADM7160	5.5 V, 200 mA, ultralow noise, linear regulator
ADP7118	20 V, 200 mA, low noise, CMOS LDO linear regulator
ADP7182	-28 V, -200 mA, low noise, LDO linear regulator

REGISTER SUMMARY

Table 10. Register Summary

Register (Hex)	Name	Bit 7	Bit 6	Bit 5	Bit 4	Bit 3	Bit 2	Bit 1	Bit 0	Default	R/W	
0x01	SW_DATA	Reserved			SW4_EN	SW3_EN	SW2_EN	SW1_EN		0x00	R/W	
0x02	ERR_CONFIG	Reserved				RW_ERR_EN	SCLK_ERR_EN	CRC_ERR_EN		0x06	R/W	
0x03	ERR_FLAGS	Reserved				RW_ERR_FLAG	SCLK_ERR_FLAG	CRC_ERR_FLAG		0x00	R	
0x05	BURST_EN	Reserved							BURST_MODE_EN		0x00	R/W
0x0B	SOFT_RESETB	SOFT_RESETB									0x00	R/W

REGISTER DETAILS

SWITCH DATA REGISTER

Address: 0x01, Reset: 0x00, Name: SW_DATA

The switch data register controls the status of the four switches of the ADGS1212.

Table 11. Bit Descriptions for SW_DATA

Bits	Bit Name	Settings	Description	Default	Access
[7:4]	Reserved		These bits are reserved; set these bits to 0.	0x0	R
3	SW4_EN	0 1	Enable bit for SW4. SW4 open. SW4 closed.	0x0	R/W
2	SW3_EN	0 1	Enable bit for SW3. SW3 open. SW3 closed.	0x0	R/W
1	SW2_EN	0 1	Enable bit for SW2. SW2 open. SW2 closed.	0x0	R/W
0	SW1_EN	0 1	Enable bit for SW1. SW1 open. SW1 closed.	0x0	R/W

ERROR CONFIGURATION REGISTER

Address: 0x02, Reset: 0x06, Name: ERR_CONFIG

The error configuration register allows the user to enable and disable the relevant error features as required.

Table 12. Bit Descriptions for ERR_CONFIG

Bits	Bit Name	Settings	Description	Default	Access
[7:3]	Reserved		These bits are reserved; set these bits to 0.	0x0	R
2	RW_ERR_EN	0 1	Enable bit for detecting invalid read/write address. Disabled. Enabled.	0x1	R/W
1	SCLK_ERR_EN	0 1	Enable bit for detecting the correct number of SCLK cycles in a SPI frame. When CRC is disabled and burst mode is disabled, 16 SCLK cycles are expected. When CRC is enabled and burst mode is disabled, 24 SCLK cycles are expected. A multiple of 16 SCLK cycles are expected when CRC is disabled and burst mode is enabled. A multiple of 24 SCLK cycles are expected when CRC is enabled and burst mode is enabled. Disabled. Enabled.	0x1	R/W
0	CRC_ERR_EN	0 1	Enable bit for CRC error detection. SPI frames are 24 bits wide when enabled. Disabled. Enabled.	0x0	R/W

ERROR FLAGS REGISTER

Address: 0x03, Reset: 0x00, Name: ERR_FLAGS

The error flags register allows the user to determine if an error occurred. To clear the error flags register, write the special 16-bit SPI command, 0x6CA9, to the device. This SPI command does not trigger the invalid R/W address error. When CRC is enabled, the user must include the correct CRC byte during the SPI write for the clear error flags register command to succeed.

Table 13. Bit Descriptions for ERR_FLAGS

Bits	Bit Name	Settings	Description	Default	Access
[7:3]	Reserved		These bits are reserved and are set to 0.	0x0	R
2	RW_ERR_FLAG	0 1	Error flag for invalid read/write address. The error flag asserts during a SPI read if the target address does not exist. The error flag also asserts when the target address of a SPI write does not exist or is read only. No error. Error.	0x0	R
1	SCLK_ERR_FLAG	0 1	Error flag for the detection of the correct number of SCLK cycles in a SPI frame. No error. Error.	0x0	R
0	CRC_ERR_FLAG	0 1	Error flag that determines if a CRC error occurred during a register write. No error. Error.	0x0	R

BURST ENABLE REGISTER

Address: 0x05, Reset: 0x00, Name: BURST_EN

The burst enable register allows the user to enable or disable burst mode. When enabled, the user can send multiple consecutive SPI commands without deasserting \overline{CS} .

Table 14. Bit Descriptions for BURST_EN

Bits	Bit Name	Settings	Description	Default	Access
[7:1]	Reserved		These bits are reserved; set these bits to 0.	0x0	R
0	BURST_MODE_EN	0 1	Burst mode enable bit. Disabled. Enabled.	0x0	R/W

SOFTWARE RESET REGISTER

Address: 0x0B, Reset: 0x00, Name: SOFT_RESETB

Use the software reset register to perform a software reset. Consecutively, write 0xA3 followed by 0x05 to this register, and the registers of the device reset to their default state.

Table 15. Bit Descriptions for SOFT_RESETB

Bits	Bit Name	Settings	Description	Default	Access
[7:0]	SOFT_RESETB		To perform a software reset, consecutively write 0xA3 followed by 0x05 to this register.	0x0	R