

Evaluating the **ADPD188BI** Integrated Optical Module and Smoke Chamber

FEATURES

Supports the detection of universal asynchronous receiver and transmitter (UART)

UDP transfer capability

Full configuration of the **ADPD188BI**

Register level

High level

Graph view

Time graph

Frequency graph

EVALUATION KIT CONTENTS

EVAL-ADPD188BIZ-S2 evaluation board

Ribbon cable

EQUIPMENT NEEDED

PC running Windows 7 or Windows 10 operating system

EVAL-ADPDUZ microcontroller board

EVAL-CHAMBER smoke chamber

DOCUMENTS NEEDED

ADPD188BI data sheet

SOFTWARE NEEDED

Wavetool Evaluation Software package

GENERAL DESCRIPTION

The EVAL-ADPD188BIZ-S2 evaluation board provides users with a simple means of evaluating the **ADPD188BI** optical module along with the **EVAL-CHAMBER** smoke chamber for smoke and aerosol detection applications.

The evaluation system is composed of the EVAL-ADPD188BIZ-S2 evaluation board, the **EVAL-ADPDUZ** microcontroller board, the optional **EVAL-CHAMBER** smoke chamber, and the **Wavetool Evaluation Software** graphical user interface (GUI). The software provides users with both low level and high level configurability, real-time frequency and time domain analysis, and user datagram protocol (UDP) transfer capability so that the evaluation board can easily interface to the user development system.

The EVAL-ADPD188BIZ-S2 is powered through the ribbon cable from the **EVAL-ADPDUZ** microcontroller board (ordered separately).

For full details on the **ADPD188BI**, see the **ADPD188BI** data sheet, which should be consulted in conjunction with this user guide when using these evaluation boards.

EVAL-ADPD188BIZ-S2 EVALUATION BOARD PHOTOGRAPH

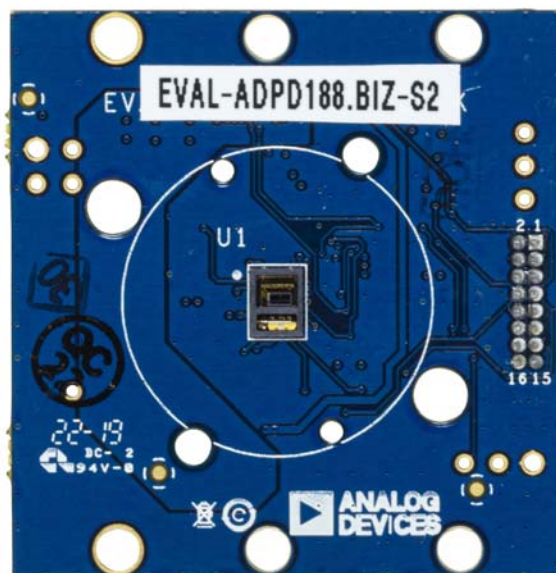


Figure 1.

TABLE OF CONTENTS

Features.....	1	Getting Started.....	3
Evaluation Kit Contents	1	Installing the Wavetool Evaluation Software.....	3
Equipment Needed.....	1	Accessing the Online User Guide and Videos.....	3
Documents Needed.....	1	Using the EVAL-CHAMBER Smoke Chamber with the	
Software Needed.....	1	EVAL-ADPD188BIZ-S2 Evaluation Board	4
General Description	1	Evaluation Board Schematics and Artwork.....	7
EVAL-ADPD188BIZ-S2 Evaluation Board Photograph.....	1		
Revision History	2		

REVISION HISTORY

3/2020—Rev. 0 to Rev. A

Updated Links to EVAL-ADPDUCZ, EVAL-CHAMBER, and Wavetool Evaluation Software Throughout

10/2019—Revision 0: Initial Version

GETTING STARTED

INSTALLING THE WAVETOOL EVALUATION SOFTWARE

Download the [Wavetool Evaluation Software](#) package from the EVAL-ADPD188BIZ-S2 product page. Navigate to the directory where the software package is downloaded to and double-click the application to install the software.

ACCESSING THE ONLINE USER GUIDE AND VIDEOS

After installing the [Wavetool Evaluation Software](#), download the [AWT Document](#), a user manual for the [Wavetool Evaluation Software](#) (see Figure 3), which allows online access to the document as well as the hardware setup. The [AWT Document](#) contains videos that show the following:

- How to install the correct drivers for the microcontroller board, [EVAL-ADPUCZ](#)
- How to install the correct firmware
- How to set up the hardware
- Information about the [Wavetool Evaluation Software](#)

To access the [AWT Document](#), take the following steps:

1. Open the [Wavetool Evaluation Software](#) application file from the directory where it was installed. Click the **Help** button (see Figure 2) on the software home screen.

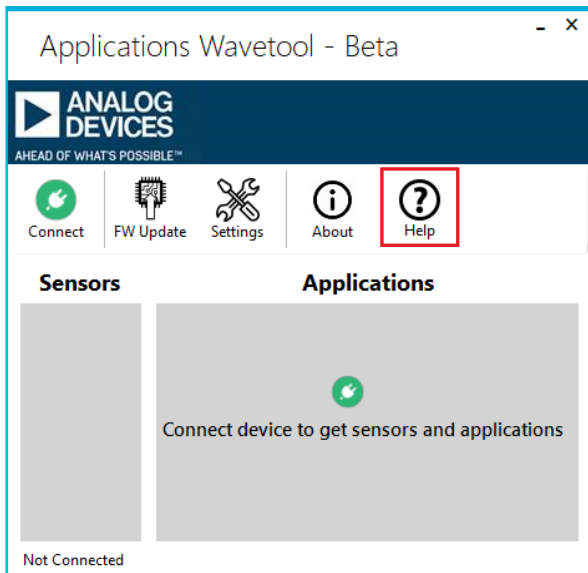


Figure 2. Applications Wavetool - Beta Home Screen

2. If this is the first time opening the [Wavetool Evaluation Software](#), users are prompted to download the [AWT Document](#) as shown in Figure 3.

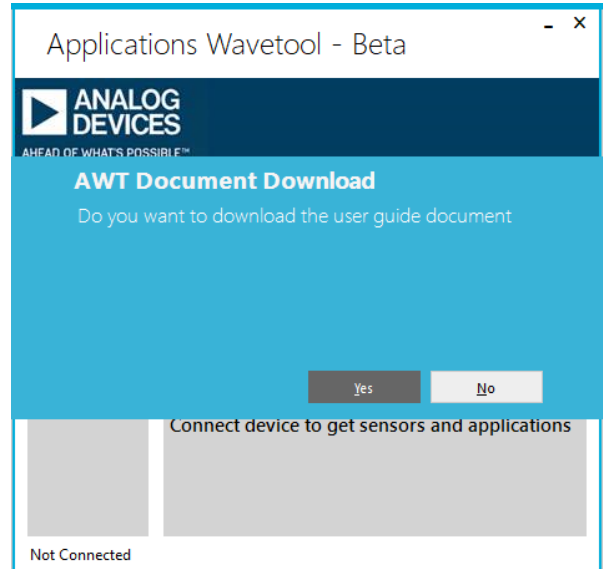


Figure 3. AWT Document Download Prompt

3. Depending on the speed of the internet connection, it can take from several seconds to a minute to download the documentation. After the document is downloaded, the prompt shown in Figure 4 appears. Click the **Ok** button to open the documentation in a browser window.

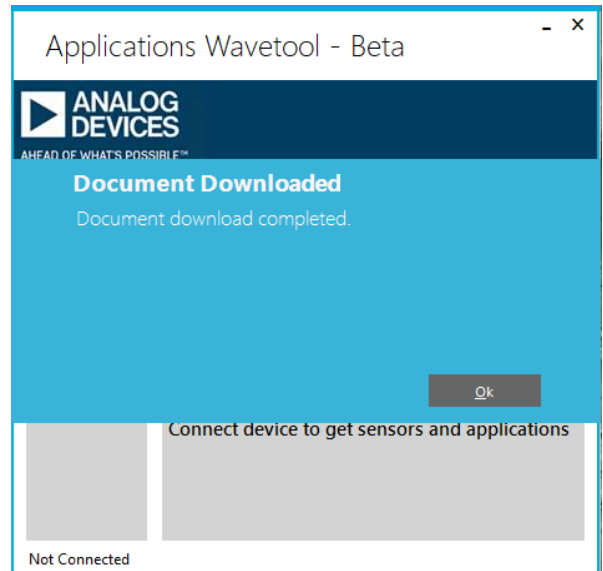


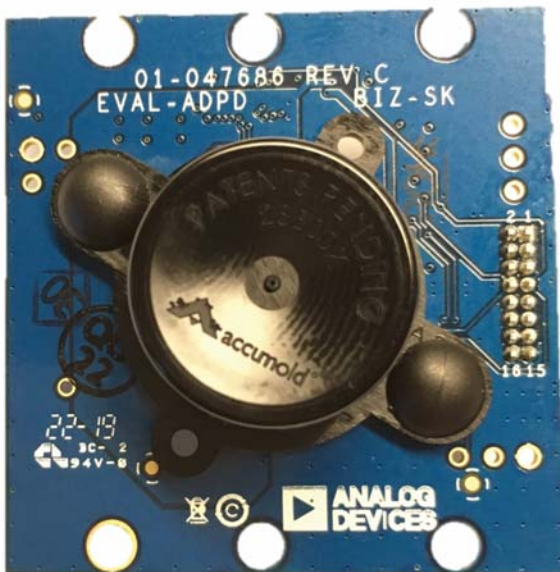
Figure 4. Document Downloaded Message

4. Click the **Help** button during subsequent initiations of the software to automatically open the user guide without the need to redownload.

All information required to operate the [Wavetool Evaluation Software](#) is found in the [AWT Document](#). Information regarding the [ADPD188BI](#) is found in the [ADPD188BI](#) data sheet.

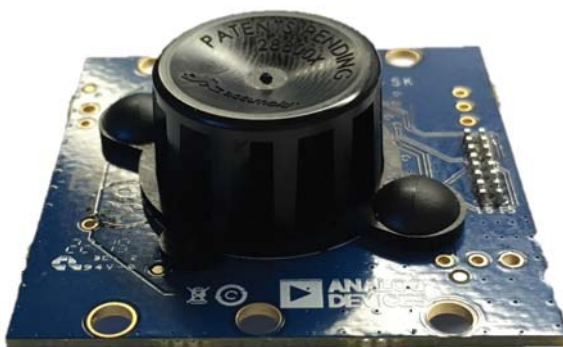
USING THE EVAL-CHAMBER SMOKE CHAMBER WITH THE EVAL-ADPD188BIZ-S2 EVALUATION BOARD

The EVAL-ADPD188BIZ-S2 evaluation board is designed to be used with the [EVAL-CHAMBER](#) smoke chamber. The smoke chamber helps control the environment around the ADPD188BI module. The [EVAL-CHAMBER](#) smoke chamber is attached to the EVAL-ADPD188BIZ-S2 evaluation board with rivets or self tapping screws. Figure 5 and Figure 6 show the smoke chamber attached to the evaluation board using rivets.



22128-005

Figure 5. Evaluation Board Attached to Chamber, Top View



22128-006

Figure 6. Evaluation Board Attached to Chamber, Side View

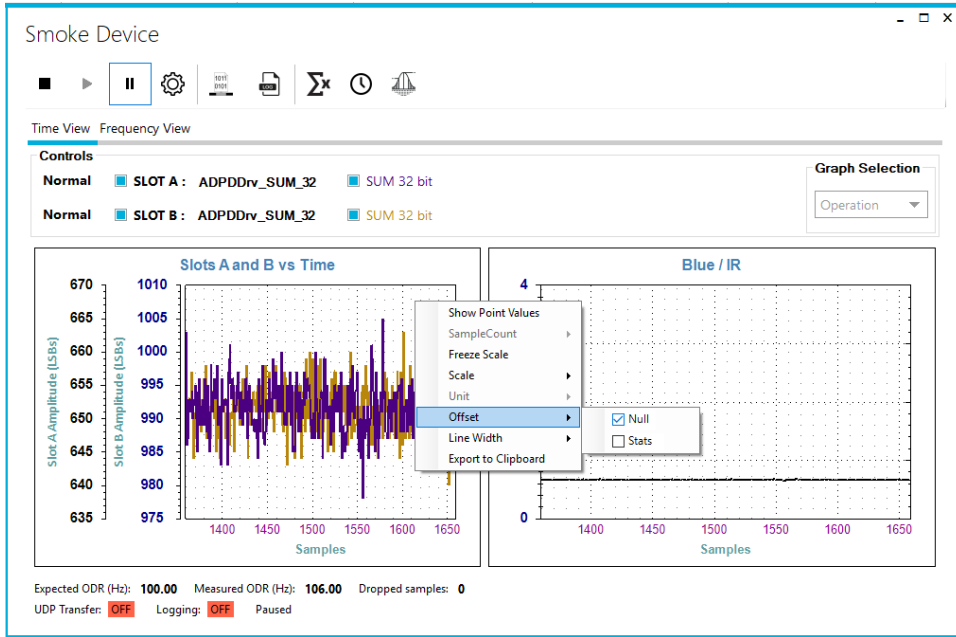
After initiating the [Wavetool Evaluation Software](#), load the default EVAL-ADPD188BIZ-S2 configuration file (comes with the software installation) and run the software with the chamber securely attached. There is some background response due to the reflection from the smoke chamber.

To have a meaningful blue/infrared (IR) ratio when smoke is present in the chamber, null the background response with the null offset feature in the software. To access the null offset feature, hover the mouse pointer over the raw data plot and right click to open the pull-down menu shown in Figure 7. Select **Offset** and check off **Null** to null the background response to zero (see Figure 7).

After nulling the background response, the ratio appears noisy (see Figure 8). The ratio appears noisy because the ratio is taken with no smoke present and the background response is nulled to approximately zero. As a result, very small numbers are dividing, and this causes large ratios. Users can ignore the ratio at this time.

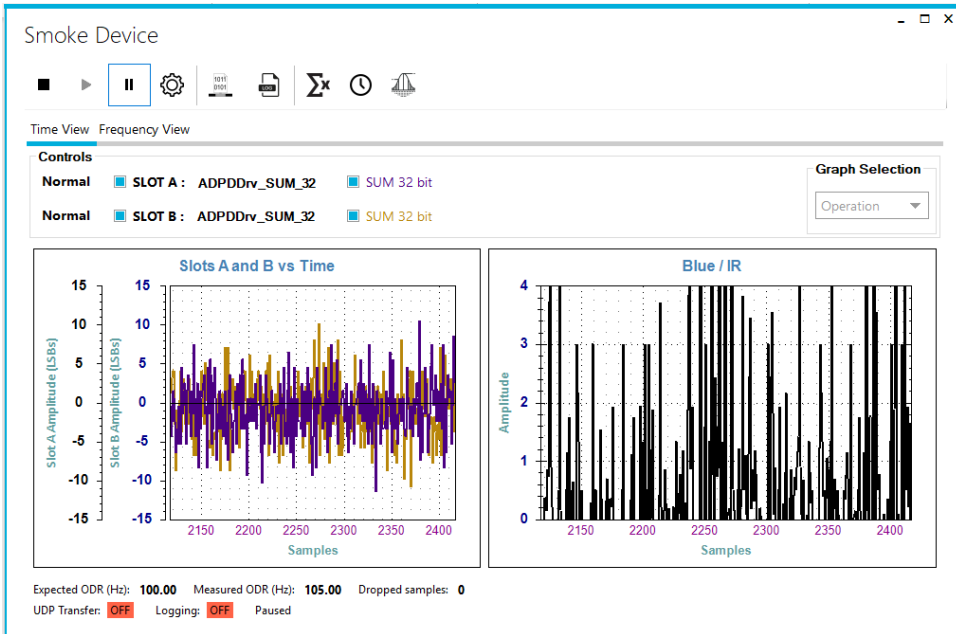
After smoke is present in the chamber, as shown in Figure 9, the raw data plot shows the individual blue and IR responses to the smoke source. The ratio shows a meaningful blue to IR ratio.

For subsequent smoke tests, clear the chamber with air. If the previous smoke test leaves residue on the chamber, users must then null the background response again prior to starting another smoke test.



22128-007

Figure 7. Null Background Response with the *Wavetool Evaluation Software*

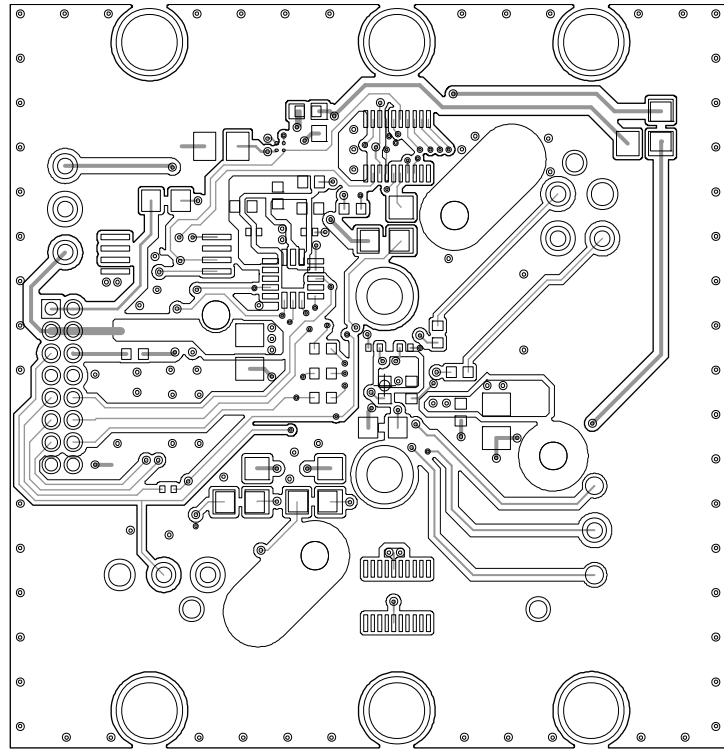


22128-008

Figure 8. Raw Data and Ratio After Null of Background Response

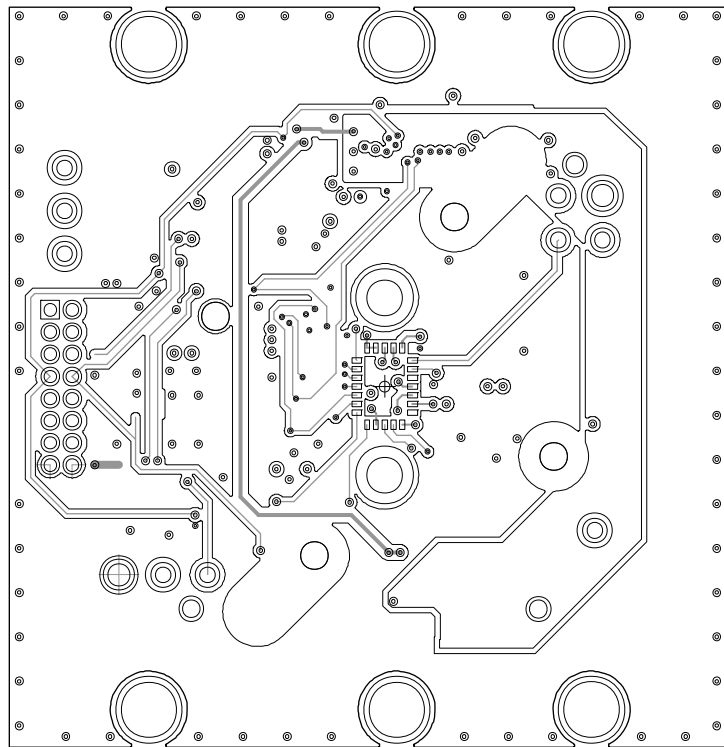


Figure 9. Raw Data and Ratio with Smoke Particles Present



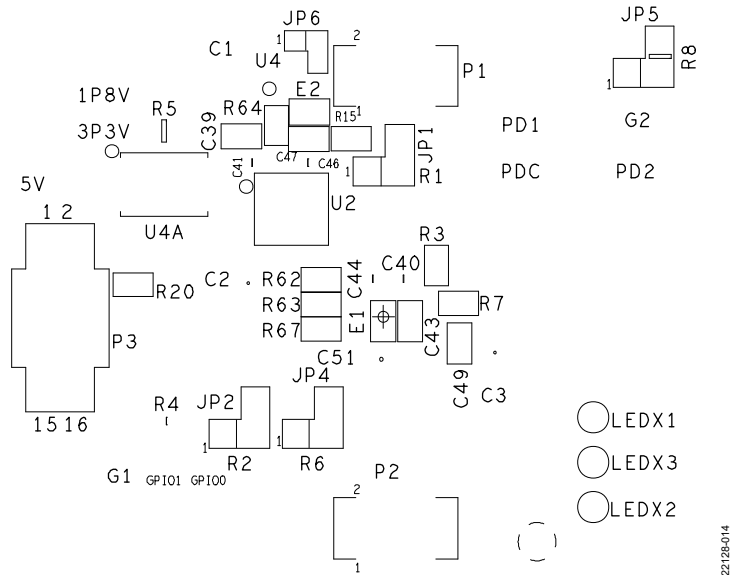
22128-012

Figure 12. EVAL-ADPD188BIZ-S2 Bottom Layer



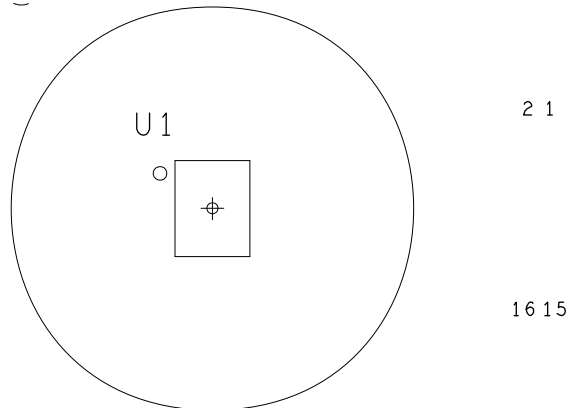
22128-013

Figure 13. EVAL-ADPD188BIZ-S2 Top Layer



22128-014

01-047686 REV B
 EVAL-ADPD188BIZ-SK



22128-015



Figure 15. EVAL-ADPD188BIZ-S2 Top Layer Silkscreen