

**Circuits
from the Lab™**
 Reference Circuits

Circuits from the Lab™ reference circuits are engineered and tested for quick and easy system integration to help solve today's analog, mixed-signal, and RF design challenges. For more information and/or support, visit www.analog.com/CN0172.

Devices Connected/Referenced

ADT7320	±0.25°C Accurate, 16-Bit Digital SPI Temperature Sensor
AD7793	3-Channel, Low Noise, Low Power, 24-Bit Σ - Δ ADC with On-Chip In-Amp and Reference

3-Channel Thermocouple Temperature Measurement System with 0.25°C Accuracy

EVALUATION AND DESIGN SUPPORT

Circuit evaluation boards

- [CN-0172 circuit evaluation board \(EVAL-CN0172-SDPZ\)](#)
- [System Demonstration Platform \(EVAL-SDP-CB1Z\)](#)
- [CN0172 breakout board \(included with EVAL-CN0172-SDPZ board\)](#)

Design and integration files

- [Schematics, Layout Files, Bill of Materials, Software](#)

CIRCUIT FUNCTION AND BENEFITS

The function of the circuit shown in Figure 1 is to provide a high accuracy multichannel thermocouple measurement solution. Achieving a precision thermocouple measurement requires a signal chain of precision components that amplifies the small thermocouple voltage, reduces noise, corrects nonlinearity, and provides accurate reference junction compensation (commonly referred to as cold junction compensation). This circuit addresses all these challenges for measuring thermocouple temperature with better than $\pm 0.25^\circ\text{C}$ accuracy.

The circuit shown in Figure 1 shows how three K type thermocouples are connected to the [AD7793](#) precision 24-bit sigma-delta (Σ - Δ) analog-to-digital converter (ADC) to measure the thermocouple voltage. Because the thermocouple is a differential device rather than an absolute temperature measurement device, the reference junction temperature must be known to get an accurate absolute temperature reading. This process is known as reference junction compensation, commonly referred to as cold junction compensation. In this circuit, the [ADT7320](#) precision 16-bit digital temperature sensor is used for the cold junction reference measurement and provides the required accuracy.

This type of application is popular where a cost-effective, accurate temperature measurement is required over the wide temperature ranges offered by thermocouples.

CIRCUIT DESCRIPTION

The circuit in Figure 1 is designed to measure the temperature of three K type thermocouples at the same time using the [AD7793](#) 24-bit Σ - Δ ADC. The reference junction temperature is measured using the [ADT7320](#), a $\pm 0.25^\circ\text{C}$ accurate, 16-bit digital SPI temperature sensor.

Thermocouple Voltage Measurement

The interface between the thermocouple and the [AD7793](#) ADC is a thermocouple connector and filter. Each connector (J1, J2, and J3) connects directly to a set of differential ADC inputs. The filter on the inputs to the [AD7793](#) reduces any noise pickup in the thermocouple leads before the signal reaches the AIN(+) and AIN(-) inputs of the ADC. The [AD7793](#) has an on-chip multiplexer, buffer, and instrumentation amplifier to amplify the small voltage from the thermocouple measurement junction.

Cold Junction Measurement

The [ADT7320](#) precision 16-bit digital temperature sensor is used to measure the reference (cold) junction temperature with an accuracy of $\pm 0.25^\circ\text{C}$ over the -20°C to $+105^\circ\text{C}$ temperature range. The [ADT7320](#) is fully calibrated at the factory, and no user calibration is required. The [ADT7320](#) contains an internal band gap reference, a temperature sensor, and a 16-bit Σ - Δ ADC to measure and digitize the temperature to 0.0078°C resolution.

Both the [AD7793](#) and [ADT7320](#) are controlled by an SPI interface using the System Demonstration Platform ([EVAL-SDP-CB1Z](#)). Both [AD7793](#) and [ADT7320](#) can also be controlled by a microcontroller.

Rev. A

Circuits from the Lab™ circuits from Analog Devices have been designed and built by Analog Devices engineers. Standard engineering practices have been employed in the design and construction of each circuit, and their function and performance have been tested and verified in a lab environment at room temperature. However, you are solely responsible for testing the circuit and determining its suitability and applicability for your use and application. Accordingly, in no event shall Analog Devices be liable for direct, indirect, special, incidental, consequential or punitive damages due to any cause whatsoever connected to the use of any Circuits from the Lab circuits. (Continued on last page)

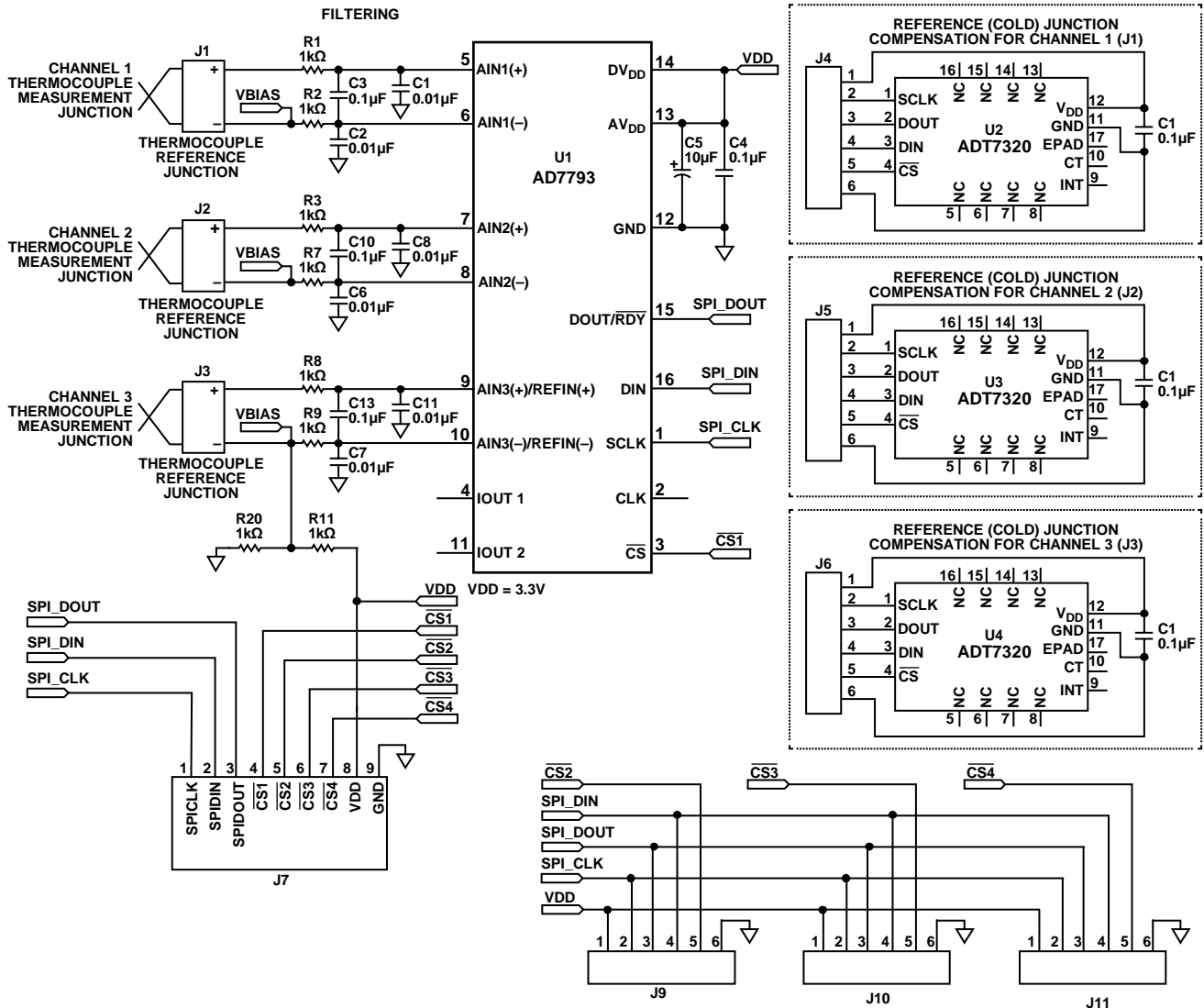

- NOTES:
1. EPAD = EXPOSED PADDLE OF THE LFCSP PACKAGE (ADT7320)
 2. THE REFERENCE (COLD) JUNCTION COMPENSATION SENSOR BOARDS CONNECTIONS TO THE REST OF THE CIRCUIT:
 - A) CHANNEL 1 (J1): J4 TO J9
 - B) CHANNEL 2 (J2): J5 TO J10
 - C) CHANNEL 3 (J3): J6 TO J11

Figure 1. Multichannel Thermocouple Measurement System (Simplified Schematic: All Connections and Decoupling Not Shown)

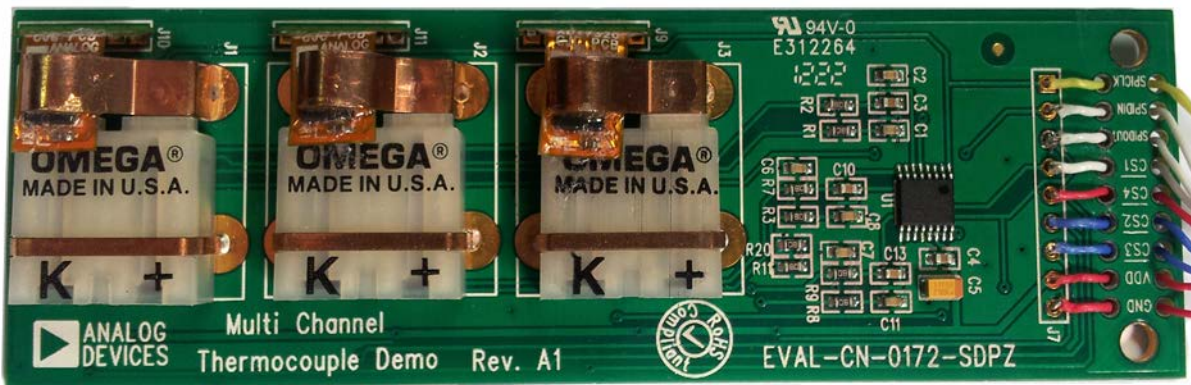

Figure 2. EVAL-CN0172-SDPZ Circuit Evaluation Board

Figure 2 shows the [EVAL-CN0172-SDPZ](#) circuit evaluation board with three K type thermocouple connectors, the [AD7793](#) ADC, and the [ADT7320](#) temperature sensor mounted on a separate flexible printed circuit board (PCB) between two copper contacts for the reference temperature measurement.

Figure 3 shows a side view of the [ADT7320](#) mounted on a separate flexible PCB and inserted between the two copper contacts of the thermocouple connector. The flexible PCB shown in Figure 3 has advantages over small FR4-type PCBs because it is thinner and more flexible. This allows the [ADT7320](#) to be mounted neatly in between the copper contacts of the thermocouple connector to minimize temperature gradients between the reference junction and [ADT7320](#).

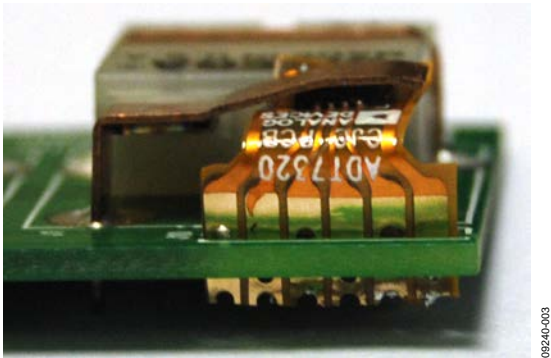

Figure 3. Side View of [ADT7320](#) Mounted on a Flexible PCB

The small size and thinness of the flexible PCB also allows the [ADT7320](#) to quickly respond to temperature changes at the reference junction. Figure 4 shows the typical thermal response time of the [ADT7320](#).

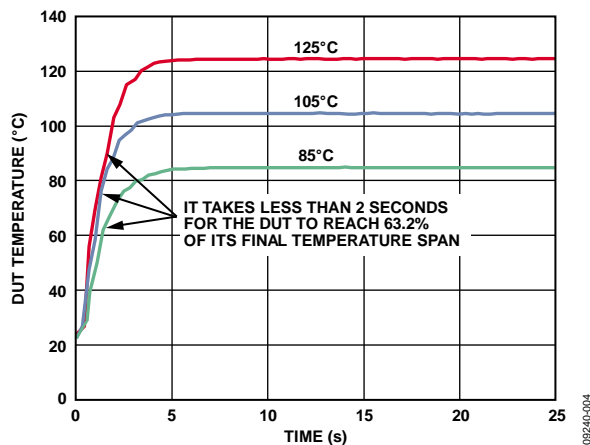

Figure 4. [ADT7320](#) Typical Thermal Response Time

This solution is flexible and allows other types of thermocouples to be used, such as J type or T type thermocouples. The K type was selected for this circuit note because of its popularity. The actual thermocouple chosen has an exposed tip. The measurement junction is outside the probe wall and is exposed to the target medium.

The advantages of the exposed tip are that it provides the best heat transfer, has the quickest response time, and is low cost and light weight. The disadvantages of the exposed tip are that it is susceptible to mechanical damage and corrosion. As a result, it is not suitable for harsh environments. However in cases where quick response time is needed, the exposed tip is the best choice. If an exposed tip is required in an industrial environment, electrical isolation may be required in the signal chain. This can be addressed by using digital isolators (see www.analog.com/icoupler).

Unlike a traditional thermistor or resistance temperature detector (RTD), the [ADT7320](#) is a fully plug-and-play solution that does not require multipoint calibration after board assembly or consume processor and memory resources with calibration coefficients and linearization routines. The [ADT7320](#) avoids self-heating issues that undermine the accuracy of traditional resistive sensor solutions because it only dissipates 700 μ W (typical) of power at 3.3 V.

Guidelines for Accurate Temperature Measurement

The following guidelines ensure that the [ADT7320](#) accurately measures the temperature of the reference junction.

Power Supply: If the [ADT7320](#) is powered from a switching regulator, noise generated above 50 kHz may affect the temperature accuracy specification. To prevent this, use an RC filter between the power supply and V_{DD} . Carefully choose the value of components used to ensure that the peak value of the supply noise is less than 1 mV.

Decoupling: The [ADT7320](#) must have a decoupling capacitor mounted as close as possible to V_{DD} to ensure accurate temperature measurement. A decoupling capacitor, such as a 0.1 μ F high frequency ceramic type is recommended. In addition, use a low frequency decoupling capacitor in parallel with the high frequency ceramic, such as a 10 μ F to 50 μ F tantalum capacitor.

Maximizing Thermal Conduction: The primary thermal path from the reference junction to the [ADT7320](#) is through the plastic package and the backside exposed paddle (GND). Because the copper contacts are connected to the ADC inputs, the backside paddle cannot be connected in this application because it affects the biasing to the ADC inputs.

Guidelines for Accurate Voltage Measurement

The following guidelines ensure that the [AD7793](#) accurately measures the voltage at the thermocouple measurement junction.

Decoupling: The [AD7793](#) must have decoupling capacitors mounted as close as possible to both AV_{DD} and DV_{DD} to ensure accurate voltage measurement. Decouple AV_{DD} with a 10 μ F tantalum capacitor in parallel with a 0.1 μ F ceramic capacitor to GND. In addition, decouple DV_{DD} with a 10 μ F tantalum capacitor in parallel with a 0.1 μ F ceramic capacitor to GND. Refer to [Tutorial MT-031](#) and [Tutorial MT-101](#) for more discussion on grounding, layout techniques, and decoupling techniques.

Filtering: The differential inputs of the [AD7793](#) act to remove most of the common-mode noise on the thermocouple lines. Differential low-pass filters comprising R1, R2, and C3, for example, placed at the front end of the [AD7793](#) reduce noise pickup that can be present in the thermocouple leads. The C1 and C2 capacitors provide additional common-mode filtering. Because the $A_{IN}(+)$ and $A_{IN}(-)$ analog inputs to the ADC are differential, most of the voltages in the analog modulator are common-mode voltages. The excellent common-mode rejection (100 dB minimum) of the [AD7793](#) further removes common-mode noise on these inputs.

Other Challenges Resolved with this Solution

The following summarizes how other challenges mentioned earlier with thermocouples are resolved with this solution.

Thermocouple Voltage Amplification: The output voltage of the thermocouple changes by only a few μ V per degree. In this case, the popular K type thermocouple changes 41 μ V/ $^{\circ}$ C. This small signal requires a large gain stage before the ADC conversion. The [AD7793](#) internal programmable gain amplifier (PGA) provides a gain up to 128. For this solution, a gain of 16 was used to allow the [AD7793](#) to run its own internal full-scale calibration using its internal reference.

Correction for Thermocouple Nonlinearity: The [AD7793](#) provides excellent linearity across a wide temperature range (-40° C to $+105^{\circ}$ C), requiring no correction or calibration by the user.

To determine the actual thermocouple temperature, the reference temperature measurement is first converted into an equivalent thermoelectric voltage using equations provided by the National Institute of Standards and Technology (NIST). This voltage is added to the thermocouple voltage measured by the [AD7793](#), and the summation is then translated back into a thermocouple temperature, again using NIST equations. An alternative approach involves using look-up tables. However, to get the same accuracy, the size of the lookup table could be substantial which would require additional memory resources from the host controller. All the processing is done in the software using the [EVAL-SDP-CB1Z](#).

Complete schematics and layouts for the [EVAL-CN0172-SDPZ](#) can be found in the CN-0172 Design Support Package: www.analog.com/CN0172-DesignSupport.

COMMON VARIATIONS

For applications that require less accuracy and precision, the [AD7792](#) 16-bit Σ - Δ ADC can be used instead of the [AD7793](#) 24-bit Σ - Δ ADC. For the reference temperature measurement, the $\pm 0.5^{\circ}$ C accurate [ADT7310](#) digital temperature sensor can be used instead of the $\pm 0.25^{\circ}$ C accurate [ADT7320](#). Both the [AD7792](#) and [ADT7310](#) are available with an SPI interface.

CIRCUIT EVALUATION AND TEST

The system described uses the [EVAL-CN0172-SDPZ](#) and the [EVAL-SDP-CB1Z](#). The CN0172 Breakout Board is included with the [EVAL-CN0172-SDPZ](#) board.

Equipment Needed

The following equipment is needed:

- An Oil bath
- The [EVAL-CN0172-SDPZ](#) circuit evaluation board
- The CN0172 Breakout Board (Included with the [EVAL-CN0172-SDPZ](#) board)
- The [EVAL-SDP-CB1Z](#) circuit evaluation board
- The [CN0172 evaluation board software](#)
- A Datron 4808 calibrator
- A Hart Scientific 1590 super thermometer
- A Hart Scientific precision probe
- GPIB cables (3)
- A PC and Windows XP or later running LabVIEW with a GPIB card and an USB 2.0 port

Setup and Test

The test setup shown in Figure 5 was used to evaluate the performance of the multichannel thermocouple solution. A Datron calibrator was used to provide a precise voltage source for the three thermocouple inputs. The temperature of the oil baths was measured with the super thermometer and controlled via the GPIB bus.

LabVIEW software for the CN0172 controls the [EVAL-CN0172-SDPZ](#) via the USB port, the [EVAL-SDP-CB1Z](#), Breakout Board, and the SPI bus. The power for the [EVAL-SDP-CB1Z](#) is obtained from the USB bus, and the 3.3 V output of the [EVAL-SDP-CB1Z](#) supplies power for the [EVAL-CN0172-SDPZ](#).

If oil bath measurements are not required, the [EVAL-CN0172-SDPZ](#) can be used to measure the three thermocouple temperatures by using the USB interface with a PC and the software provided on the CD.

Information and details regarding test setup and calibration, and how to use the evaluation software for data capture can be found in the CN0172 User Guide found at: www.analog.com/CN0172-UserGuide.

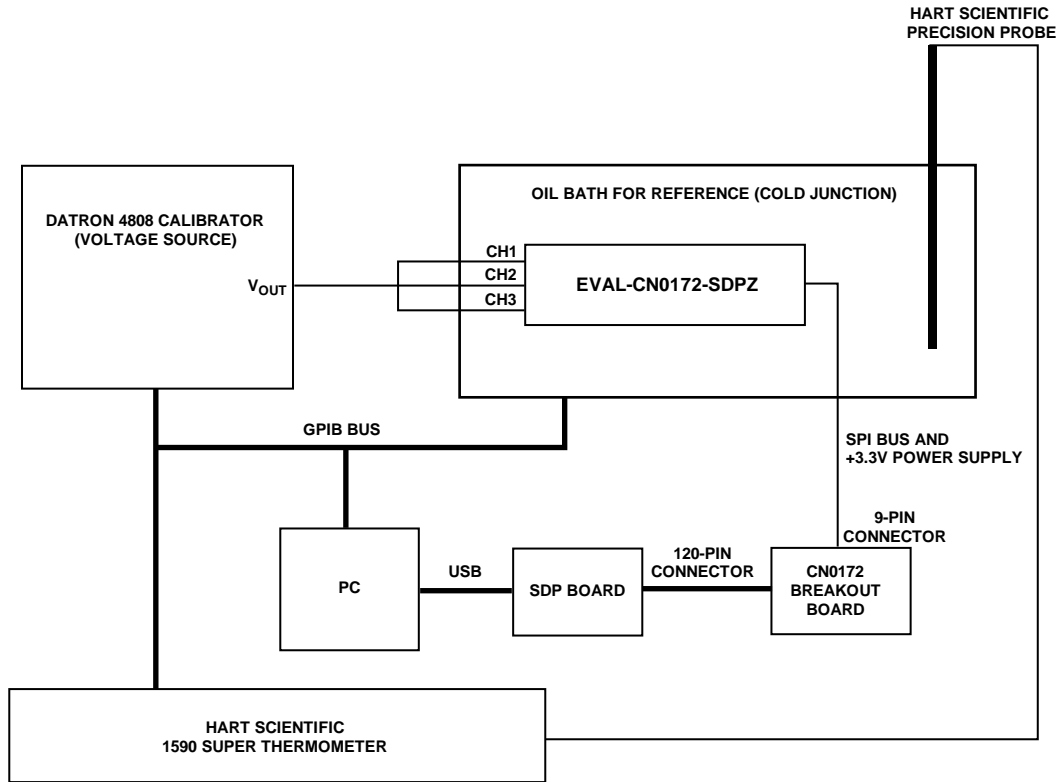

Figure 5. Test Setup Functional Block Diagram

Test Results

Figure 6 shows a plot of the thermocouple solution error over various thermocouple temperatures using various fixed values of cold junction (CJ) temperatures. Total solution error $\leq \pm 0.25^\circ\text{C}$ is achieved over a wide temperature range. Note that the accuracy of the solution can be further improved by performing a system calibration of the AD7793 ADC.

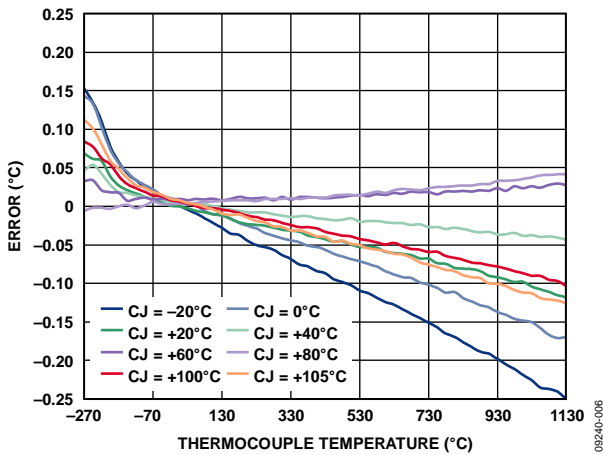

Figure 6. Error vs. Thermocouple Temperature for Fixed Cold Junction (CJ) Temperature

Figure 7 shows a plot of the thermocouple solution error over various CJ temperatures using various fixed values of thermocouple temperatures. Total solution error $\leq \pm 0.25^\circ\text{C}$ is achieved over a wide temperature range.

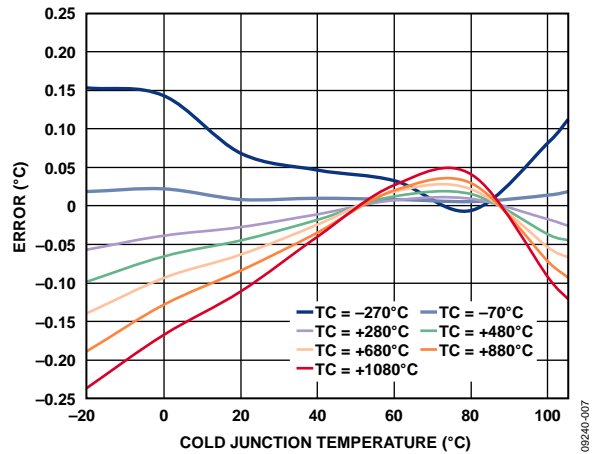

Figure 7. Error vs. Cold Junction Temperature for Fixed Thermocouple Temperatures