

Evaluation Board for Differential Amplifiers Offered in 8-Lead SOIC Packages

FEATURES

- Flexible board layout allows for various circuit configurations**
- Accommodates the [ADA4940-1](#) and the [AD813x](#) family of differential amplifiers in 8-lead SOIC packages**
- Enables quick breadboarding/prototyping**
- Edge-mounted SMA connector provisions**
- Easy connection to test equipment and other circuits**
- RoHS compliant**

GENERAL DESCRIPTION

The Analog Devices, Inc., 8-lead SOIC evaluation board for differential drivers is designed to help users evaluate differential drivers offered in 8-lead standard small outline (SOIC) packages. The 8-lead SOIC differential driver evaluation board makes it easy for designers to obtain quick performance results for their specific differential driver application circuits.

The 8-lead SOIC evaluation board is a bare board (that is, no components are soldered to the board) that enables users to quickly prototype a variety of differential driver circuits, thereby minimizing risk and reducing time to market. The board layout is very flexible and allows for many circuit configurations, including traditional four-resistor circuits, circuits with two different feedback loops, filters, and many others. Most resistors and capacitors use 1206, 0402, 0508, and 0603 packages.

Figure 1 shows the component side of the bare evaluation board, and Figure 2 shows the circuit side of the evaluation board.

Because this universal evaluation board can be used with many Analog Devices differential amplifiers in 8-lead SOIC packages, the evaluation board label does not contain specific part numbers.

The board accommodates the [ADA4940-1](#), as well as many members of the [AD813x](#) family of differential amplifiers (see the Related Links section). The data sheets for these devices should be consulted in conjunction with this evaluation board user guide.

EVALUATION BOARD COMPONENT AND CIRCUIT SIDE DIAGRAMS

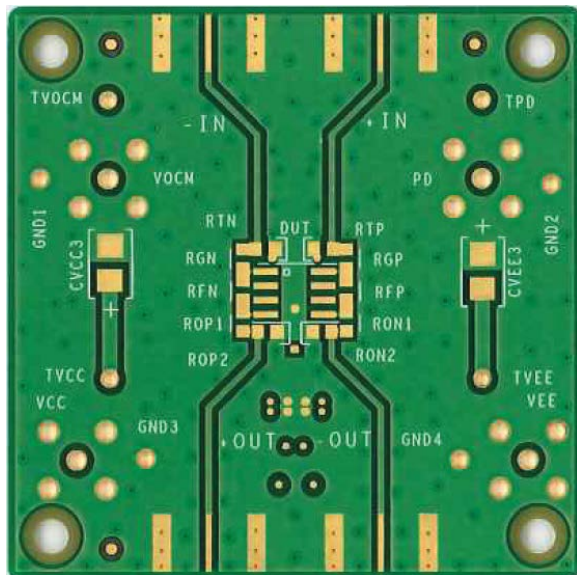

Figure 1. Evaluation Board, Component Side

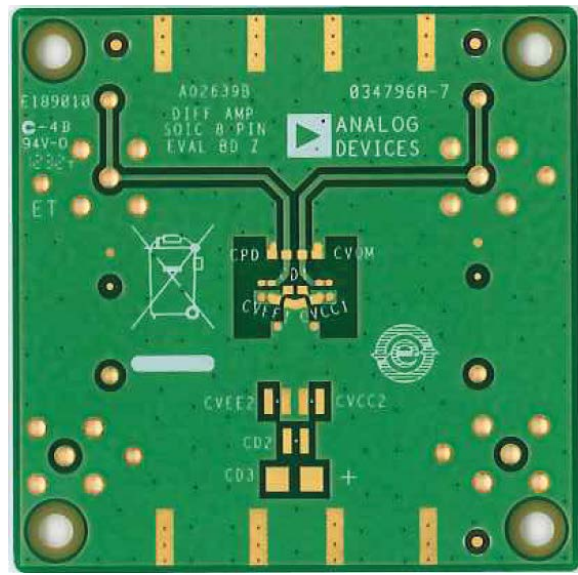

Figure 2. Evaluation Board, Circuit Side

TABLE OF CONTENTS

Features	1	V_{OCM} Input.....	4
General Description	1	Common-Mode Voltage.....	4
Evaluation Board Component and Circuit Side Diagrams.....	1	SMA Input/Output Connectors	4
Revision History	2	Evaluation Board Silkscreens and Assembly Drawings	5
Evaluation Board Schematic	3	Ordering Information.....	6
Evaluation Board Hardware	4	Bill of Materials.....	6
Power Supplies	4	Related Links.....	6
Feedback Networks and Input/Output Terminations	4		

REVISION HISTORY

9/12—Revision 0: Initial Version

EVALUATION BOARD SCHEMATIC

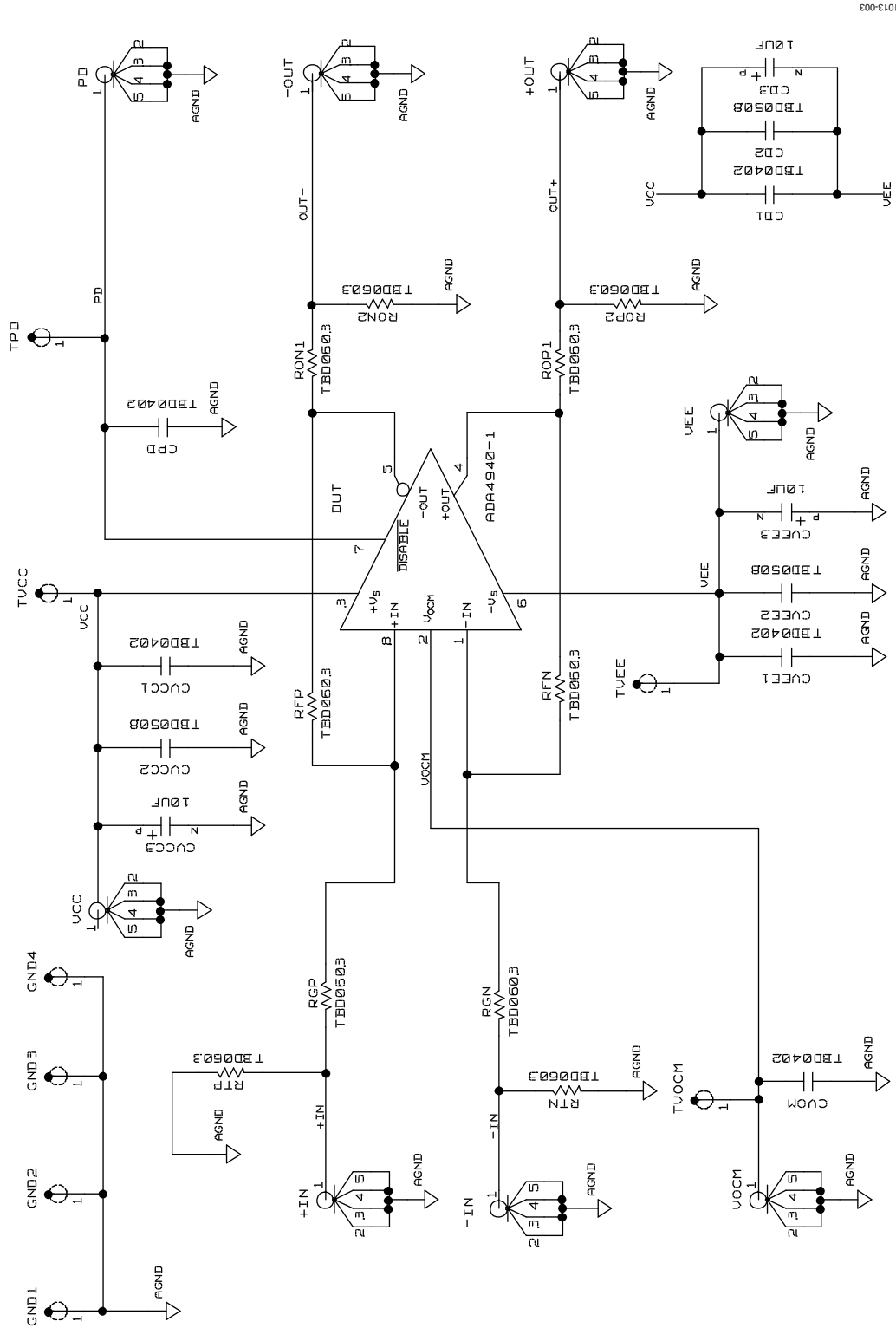

11013-003

Figure 3. Differential Driver Evaluation Board Schematic, 8-Lead SOIC

EVALUATION BOARD HARDWARE

POWER SUPPLIES

Power is applied to the evaluation board through the TVCC and TVEE test points (see Figure 3). The board accommodates single or dual supplies. For single-supply operation, connect the negative supply to the ground plane.

It is very important that the power supply pins of the device under test (DUT) have broadband decoupling circuitry. The board layout facilitates this with footprints for 0508 ceramic capacitors (CVCC2 and CVEE2) on each supply, as well as 0402 ceramic capacitors (CVCC1 and CVEE1). Bulk decoupling is provided by CVCC3 and CVEE3; 10 μ F tantalum capacitors are recommended.

FEEDBACK NETWORKS AND INPUT/OUTPUT TERMINATIONS

Resistors RGN and RFN comprise the negative resistive feedback loop, and Resistors RGP and RFP comprise the positive feedback loop (see Figure 3). To minimize summing node capacitances, the ground plane under and around Pin 1 and Pin 8 of the DUT and the copper that connects to them have been removed.

Resistors RTN and RTP are included as input termination resistors for applications that have single-ended inputs.

V_{OCM} INPUT

An external voltage can be applied to the V_{OCM} pin via the TVOCM test point (referenced to the ground plane of the board). In ADC driver applications, it is convenient to apply the ADC dc reference voltage output directly. The CVOM component position can be used for both resistors and capacitors. A 0.1 μ F capacitor is used in normal applications to provide bypassing for the dc voltage applied to the V_{OCM} pin.

It is also possible to drive the V_{OCM} input from an external ac source. In this case, omit CVOM, or reduce it to a value that allows the desired signal to be passed.

COMMON-MODE VOLTAGE

The internal common-mode feedback loop used in the differential drivers forces the output common-mode voltage to be equal to the voltage applied to the V_{OCM} input, thereby providing excellent output balance.

SMA INPUT/OUTPUT CONNECTORS

The inputs and outputs have edge-mounted SMA connectors for convenient connection to coaxial cables. The recommended connector is Part No. 142-0701-801 from Johnson Components, or equivalent.

EVALUATION BOARD SILKSCREENS AND ASSEMBLY DRAWINGS

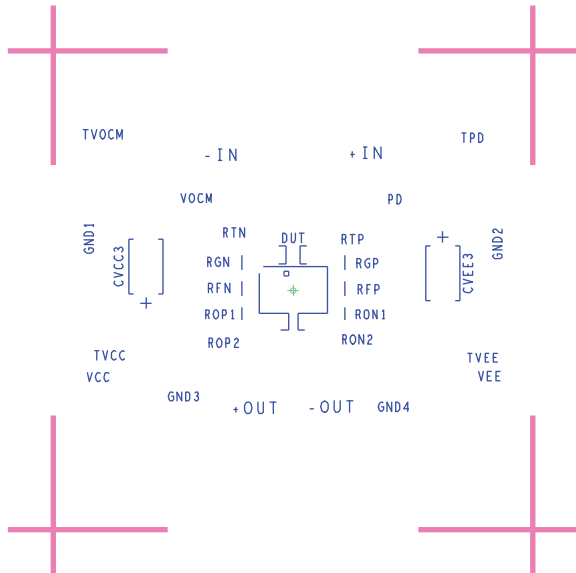

Figure 4. Top Silkscreen

11013-004

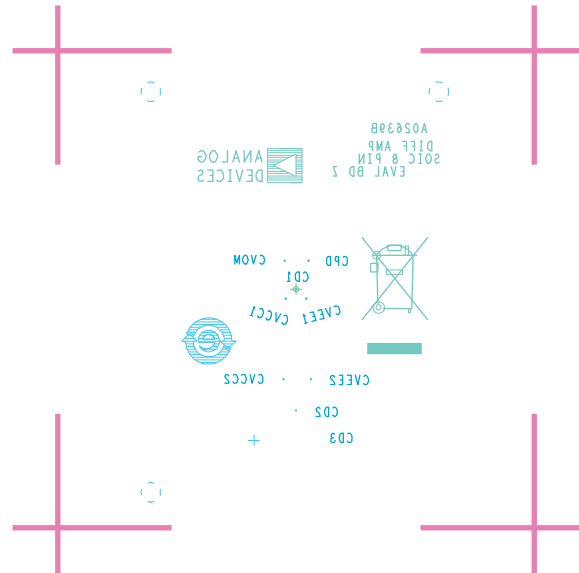

Figure 5. Bottom Silkscreen

11013-005

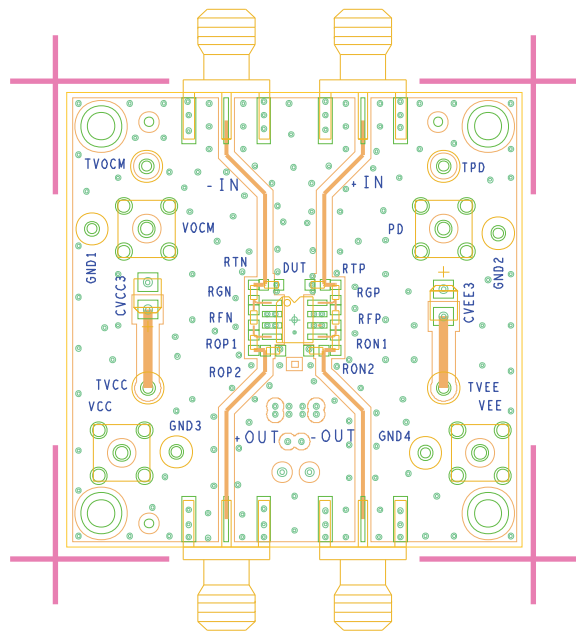

Figure 6. Component Side Assembly Drawing

11013-006

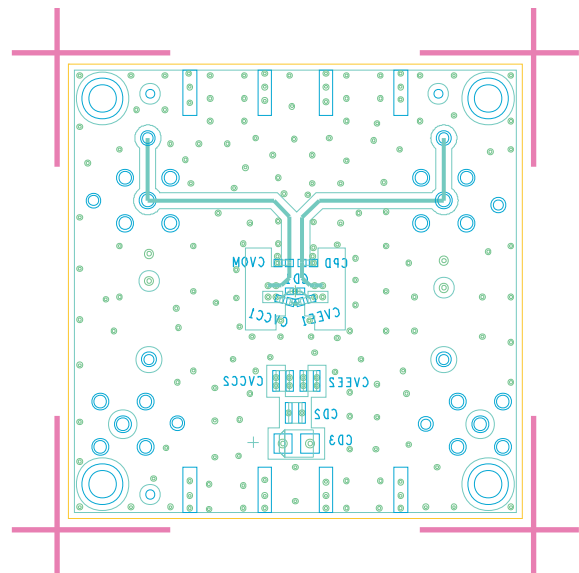

Figure 7. Circuit Side Assembly Drawing

11013-007

ORDERING INFORMATION**BILL OF MATERIALS**

Table 1.

Qty	Reference Designator	Description	Package
3	CVCC3, CVEE3, CD3	Capacitor, 10 μ F	C1206
3	CVCC2, CVEE2, CD2	Capacitor, 0.1 μ F	C0508
3	CVCC1, CVEE1, CD1	Capacitor, 0.1 μ F	C0402
2	CPD, CVOM	Capacitor/resistor	C0402
4	-IN, +IN, -OUT, +OUT	Side launch SMA connector	SMA/SMT
4	VCC, VEE, VOCM, PD	Vertical launch SMA connector	SMA/SMT
10	RTN, RTP, RGP, RGN, RFP, RFN, ROP1, RON1, ROP2, RON2	Resistor, user-defined value	R0603
8	TVCC, TVEE, TVOCM, TPD, GND1 to GND4	Test point	TP1
1	DUT	Device under test	8-lead SOIC
1	PCB	PC board	

RELATED LINKS

Table 2.

Resource	Description
ADA4940-1	Product Page, Ultralow Power, Low Distortion Differential ADC Driver
AD8131	Product Page, Low Cost, High Speed Differential Driver with a Fixed Gain of 2
AD8132	Product Page, Low Cost, High Speed Differential Amplifier
AD8137	Product Page, Low Cost, Low Power Differential ADC Driver
AD8138	Product Page, Low Distortion Differential ADC Driver
AD8139	Product Page, Ultralow Noise, Rail-to-Rail Differential ADC Driver

NOTES