

Evaluation Board for Single, High Speed Operational Amplifiers (8-Lead SOIC and Exposed Paddle)

FEATURES

- Enables quick breadboarding/prototyping**
- User-defined circuit configuration**
- Edge-mounted SMA connector provisions**
- Easy connection to test equipment and other circuits**

GENERAL DESCRIPTION

The EB-O8RE-1Z is designed to aid in the evaluation of single, high speed operational amplifiers. The EB-O8RE-1Z is a bare board (that is, there are no components soldered to the board) that enables users to quickly prototype a variety of operational amplifier circuits, which minimizes risk and reduces time to market. The EB-O8RE-1Z evaluation board supports any of the Analog Devices, Inc., single, high speed operational amplifiers in an 8-lead SOIC package with an exposed paddle.

Figure 1 shows the component side of the evaluation board, and Figure 2 shows the circuit side of the evaluation board. Figure 3 shows the evaluation board schematic.

The 4-layer evaluation board accepts edge-mounted SMA connectors on both inputs and outputs, which allows efficient and quick connection to test equipment or other circuitry.

The board ground plane, component placement, and power supply bypassing are optimized for maximum circuit flexibility and performance. The evaluation board uses a variety of SMT component case sizes: 0402, 0508, 0603, and 7343.

Figure 4 and Figure 6 show the evaluation board assembly drawings. Figure 5 and Figure 7 show the metal layout pattern for connecting the board to the op amp and to the supporting circuitry.

EVALUATION BOARD COMPONENT AND CIRCUIT SIDE DIAGRAMS

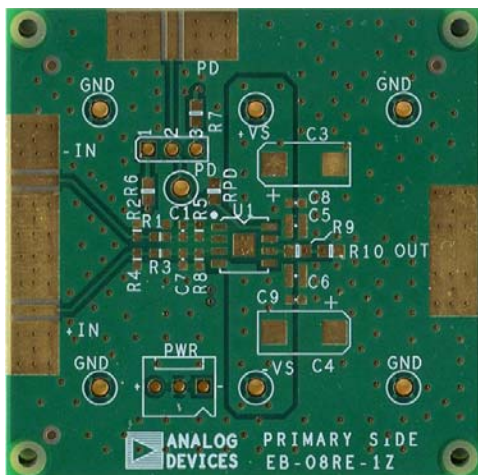

NOTES

1. THE EVALUATION BOARD SILKSCREEN PART NUMBER LABELING ON YOUR BOARD MAY BE DIFFERENT FROM WHAT IS SHOWN HERE.

08995-001

Figure 1. EB-O8RE-1Z Component Side of Evaluation Board

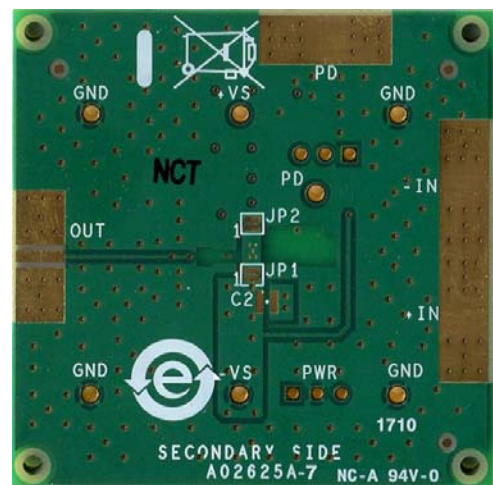

NOTES

1. THE EVALUATION BOARD SILKSCREEN PART NUMBER LABELING ON YOUR BOARD MAY BE DIFFERENT FROM WHAT IS SHOWN HERE.

08995-002

Figure 2. EB-O8RE-1Z Circuit Side of Evaluation Board

TABLE OF CONTENTS

Features	1	Evaluation Board Schematic, Assembly Drawings, and Board	
General Description	1	Layouts	3
Evaluation Board Component and Circuit Side Diagrams.....	1	Noninverting Configuration.....	5
Revision History	2	Ordering Information.....	6
		Bill of Materials.....	6

REVISION HISTORY

4/10—Revision 0: Initial Version

EVALUATION BOARD SCHEMATIC, ASSEMBLY DRAWINGS, AND BOARD LAYOUTS

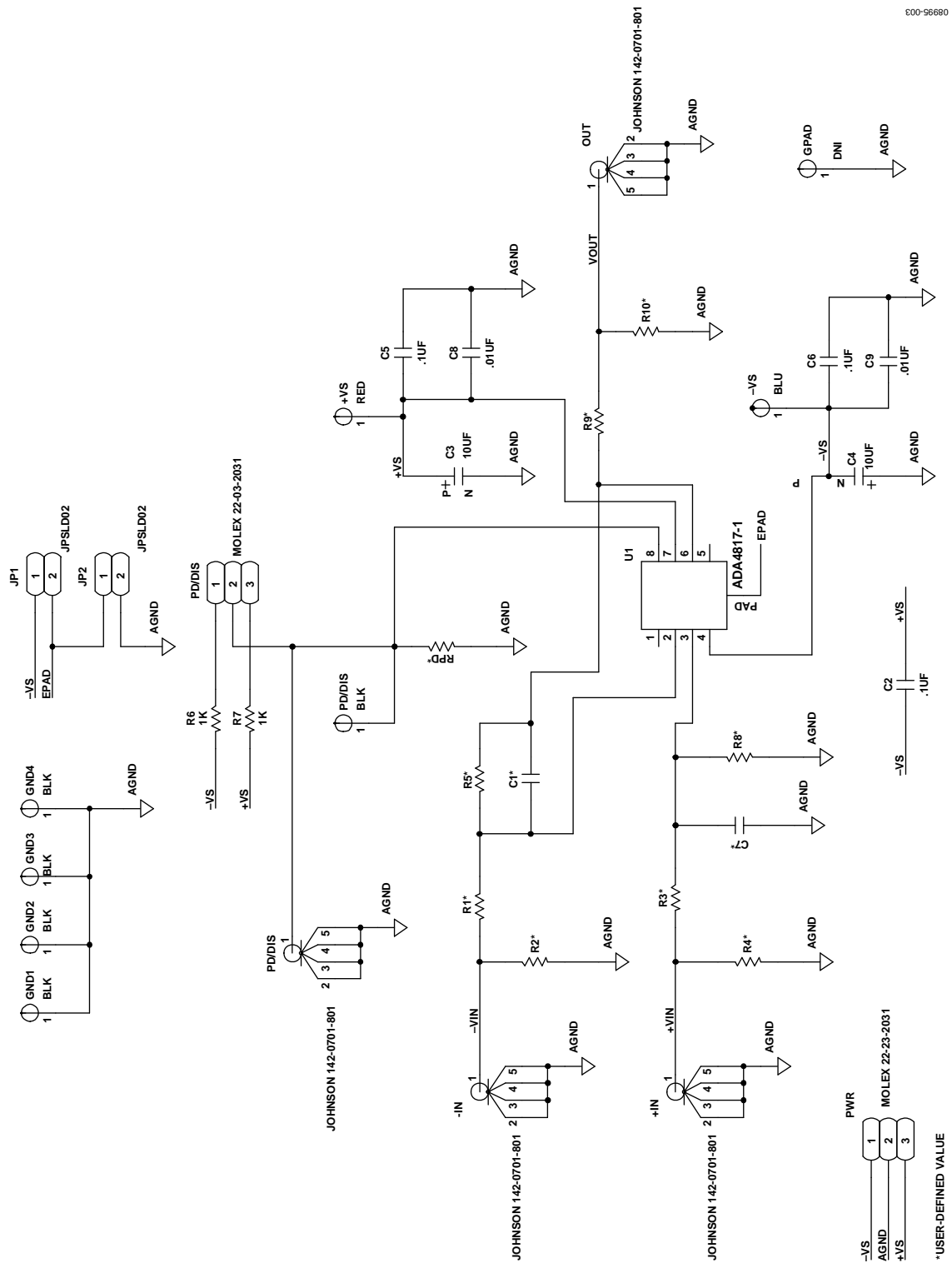

Figure 3. EB-O8RE-1Z Universal Evaluation Board Schematic

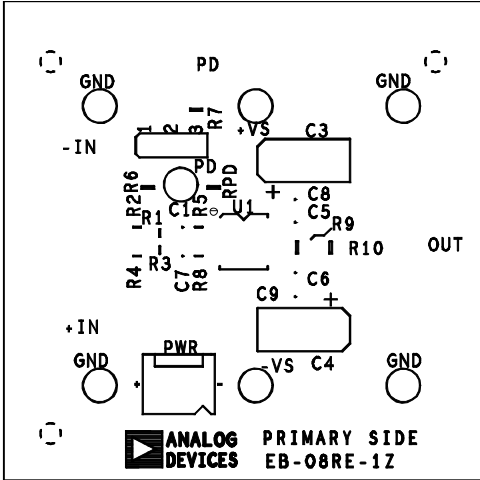

Figure 4. Board Assembly Drawing, Component Side

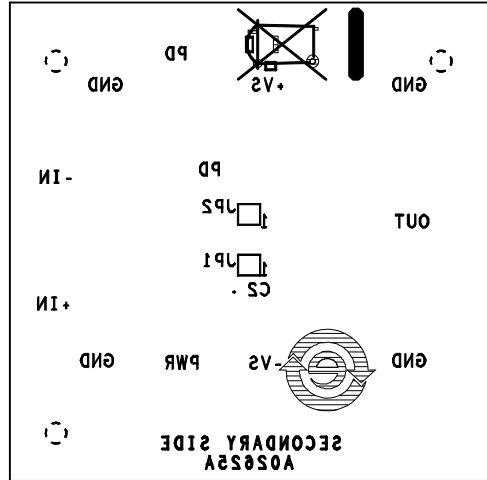

Figure 6. Board Assembly Drawing, Circuit Side

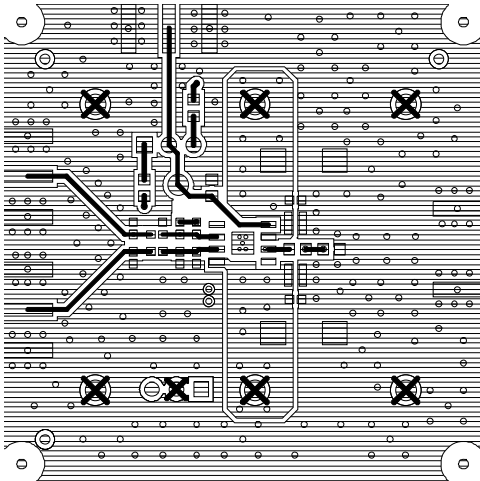

Figure 5. Board Layout Pattern, Component Side

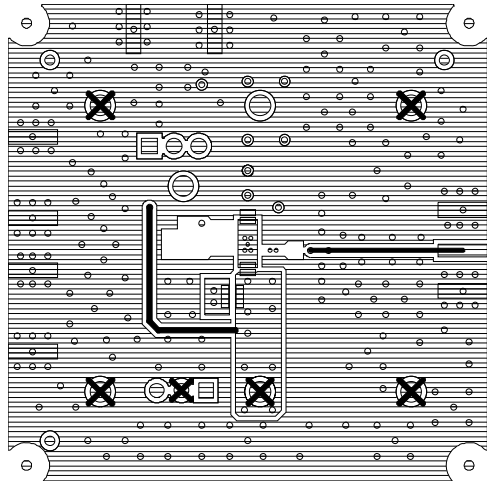

Figure 7. Board Layout Pattern, Circuit Side

NONINVERTING CONFIGURATION

When using this board in a noninverting configuration, with a gain larger than 1, there are two recommended ways to place the gain resistor. The first way is to place the gain resistor in the R1 location and use a $0\ \Omega$ resistor for the R2 location to short to ground. The second way is to place the gain resistor between the first pad of R1 and ground, without using a second resistor (see Figure 8).

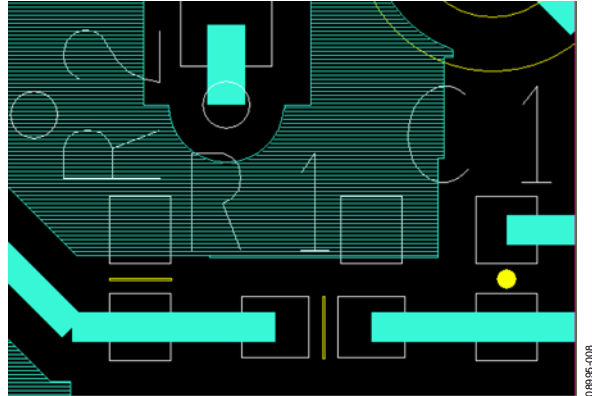

Figure 8. Noninverting Configuration with a Gain of Higher Than 1

ORDERING INFORMATION**BILL OF MATERIALS**

Table 1.

Quantity	Reference Designator	Description	Package
4	+IN, -IN, OUT, PD/DIS	SMA/SMT	SMA/SMT
2	C1, C7	User-defined capacitor	C0402
2	C8, C9	0.01 μ F capacitor	C0402
3	C2, C5, C6	0.1 μ F capacitor	C0508
2	C3, C4	10 μ F capacitor	C6032
6	R1, R2, R3, R4, R5, R8	User-defined resistor	R0402
3	R9, R10, RPD	User-defined resistor	R0603
2	R6, R7	1 k Ω	R0603
7	PD/DIS, GND1, GND2, GND3, GND4, +VS, -VS	Test point	TP
1	PWR	Header 3 POS	Molex 22-23-2031
1	PD/DIS	3-pin straight header	Molex 22-03-2031
2	JP1, JP2	User-defined jumper	Solder jumper
1	U1	Amplifier	8-lead SOIC

NOTES