

## Door zone evaluation board based on L99DZ200G

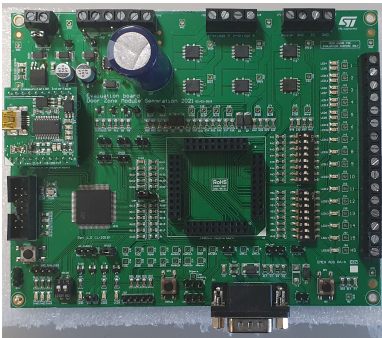

**Motherboard**

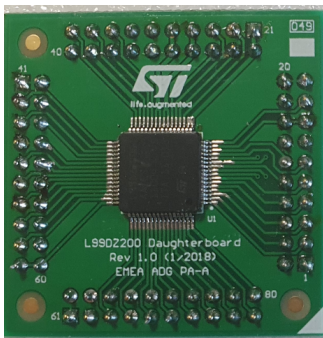

**Daughter board**

### Product status link

[EVAL-L99DZ200](#)

### Product summary

<b>Order code</b>	EVAL-L99DZ200
<b>Related device</b>	L99DZ200G motherboard and daughter board

### Features

- Board functionality based on L99DZ200G, automotive front door device with LIN and CAN providing dual H-bridge driving
- Mother Board size: 150 mm length x 120 mm width
- Daughter Board size: 36.8 mm length x 35.6 mm width
- Board reverse battery protection with STL64N4F7AG Power MOSFET
- H-bridge with 4 x STL76N4F7AG Power MOSFETs
- Heater and electro chrome with 2x STL19N3LLH6AG Power MOSFETs
- FDTI for PC control via USB
- All ST components are automotive-grade qualified

### Application

- Front drives Rear door zone architecture
- Power trunk / tailgate

### Description

The EVAL-L99DZ200 evaluation board is designed for the Front drives Rear door zone architecture and for the power trunk applications.

The board is composed by a motherboard and a daughter board. The motherboard, which is based on the SPC582B60 microcontroller, provides the logic section for monitoring and driving the L99DZ200G device assembled on the daughter board.

With the aim of facilitating the use and configuration of the board, STMicroelectronics provides a dedicated user-friendly software with a graphic user interface (GUI). This GUI enables the user to set the L99DZ200G control parameters and at the same time shows real time diagnostics information as current output and battery voltage monitoring.

# 1 Application schematics and layout

## 1.1 Overall application diagram

Figure 1. EVAL-L99DZ200 application diagram

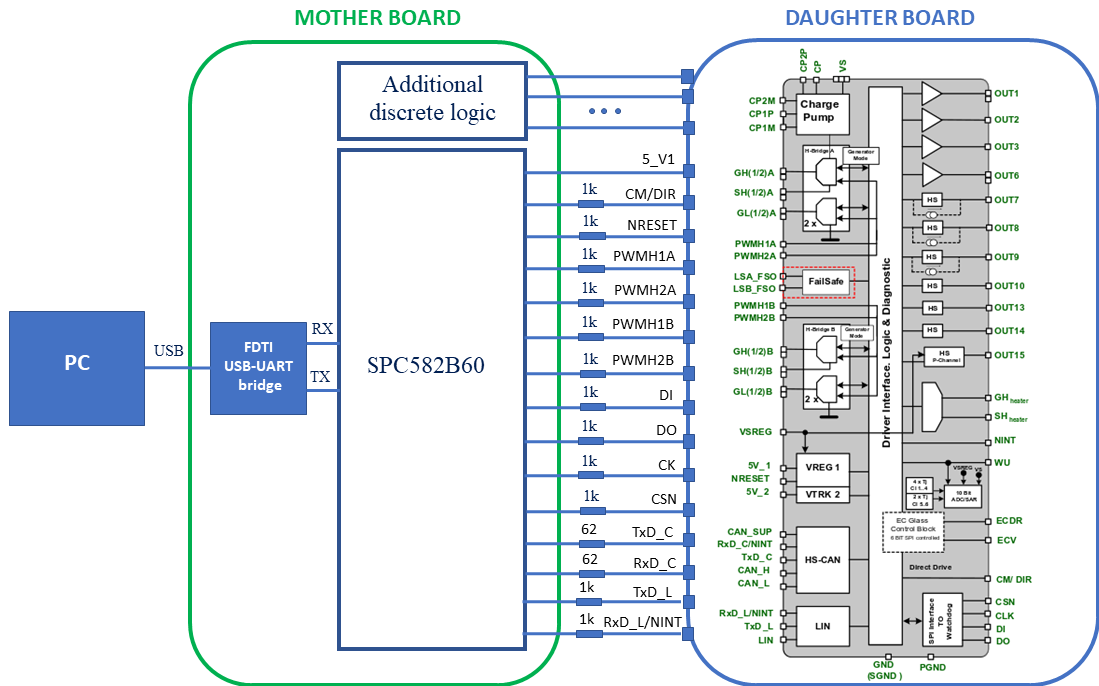

## 1.2 EVAL-L99DZ200 motherboard

Figure 2. EVAL-L99DZ200 motherboard top layer

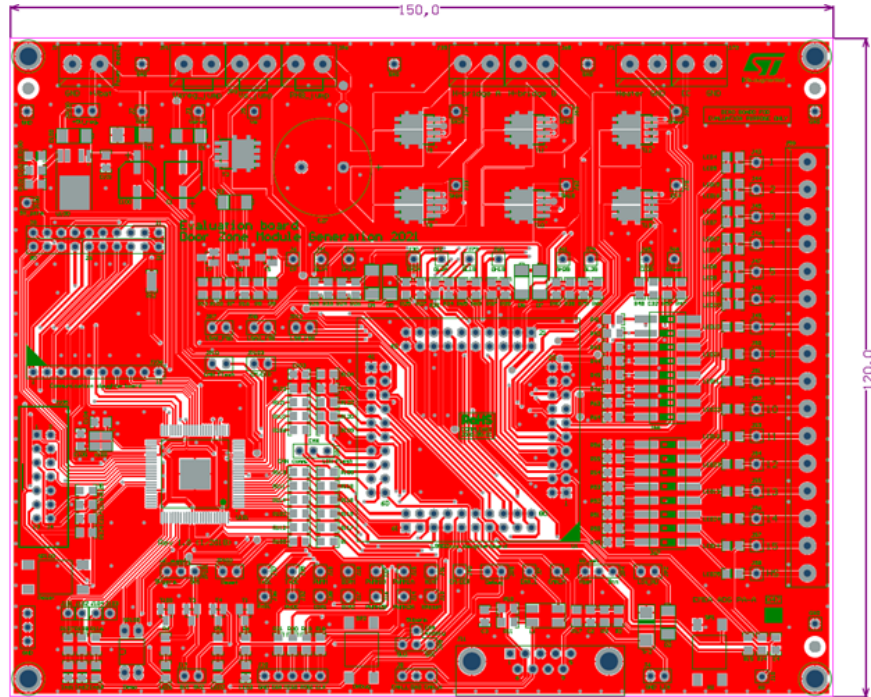
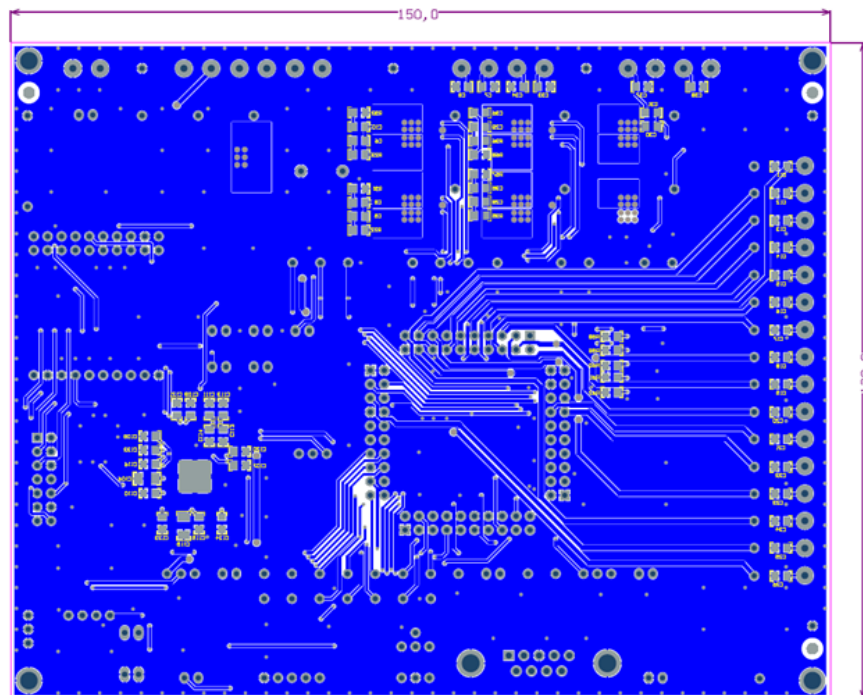
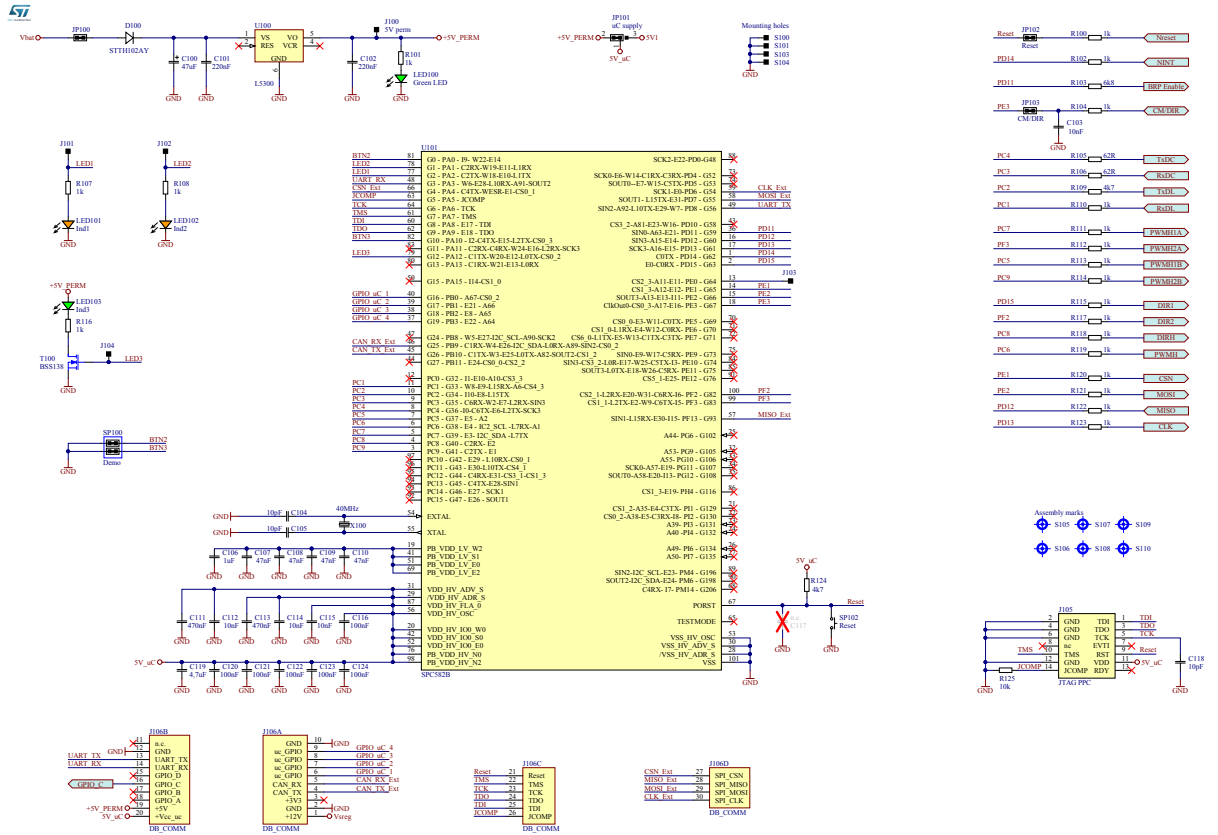

Figure 3. EVAL-L99DZ200 motherboard bottom layer



### Figure 4. EVAL-L99DZ200 motherboard schematics (1 / 2)



**Figure 5. EVAL-L99DZ200 motherboard schematics ( 2 / 2 )**

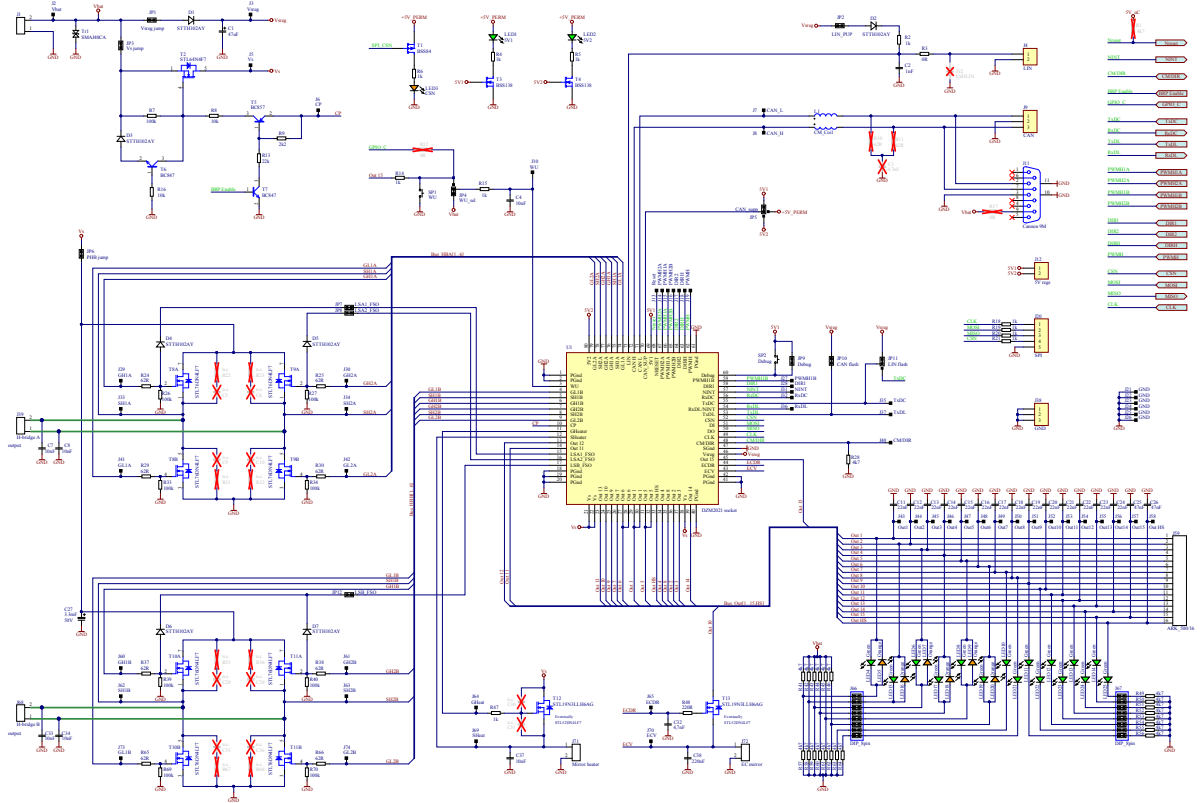

### 1.3 EVAL-L99DZ200 daughter board

Figure 6. EVAL-L99DZ200 daughter board top layer

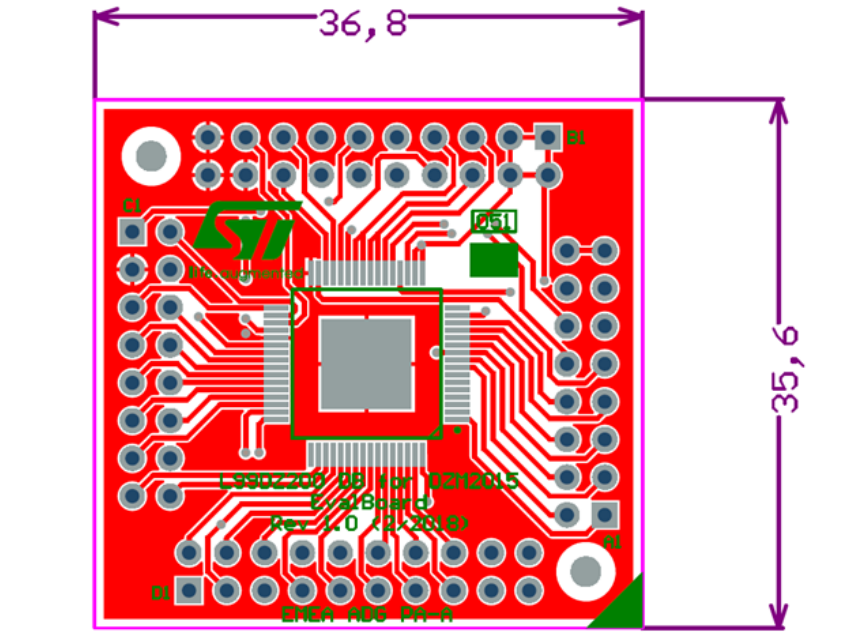

Figure 7. EVAL-L99DZ200 daughter board bottom layer

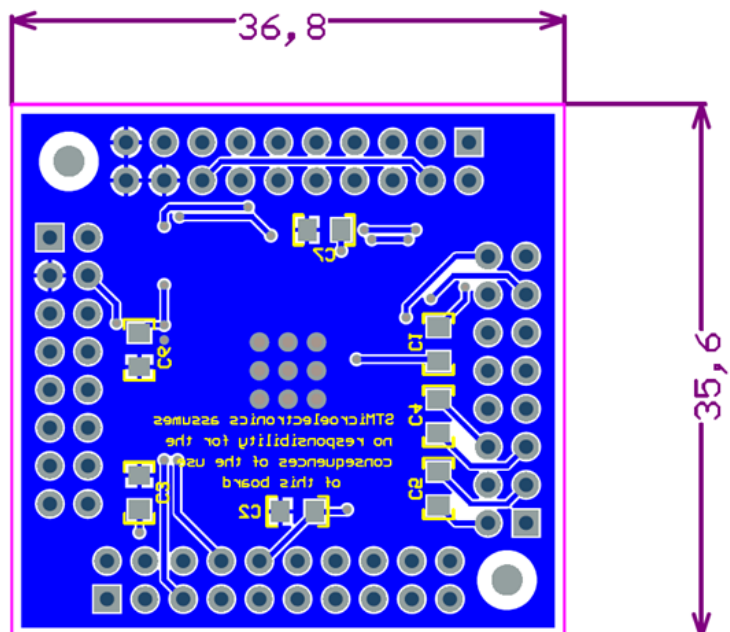
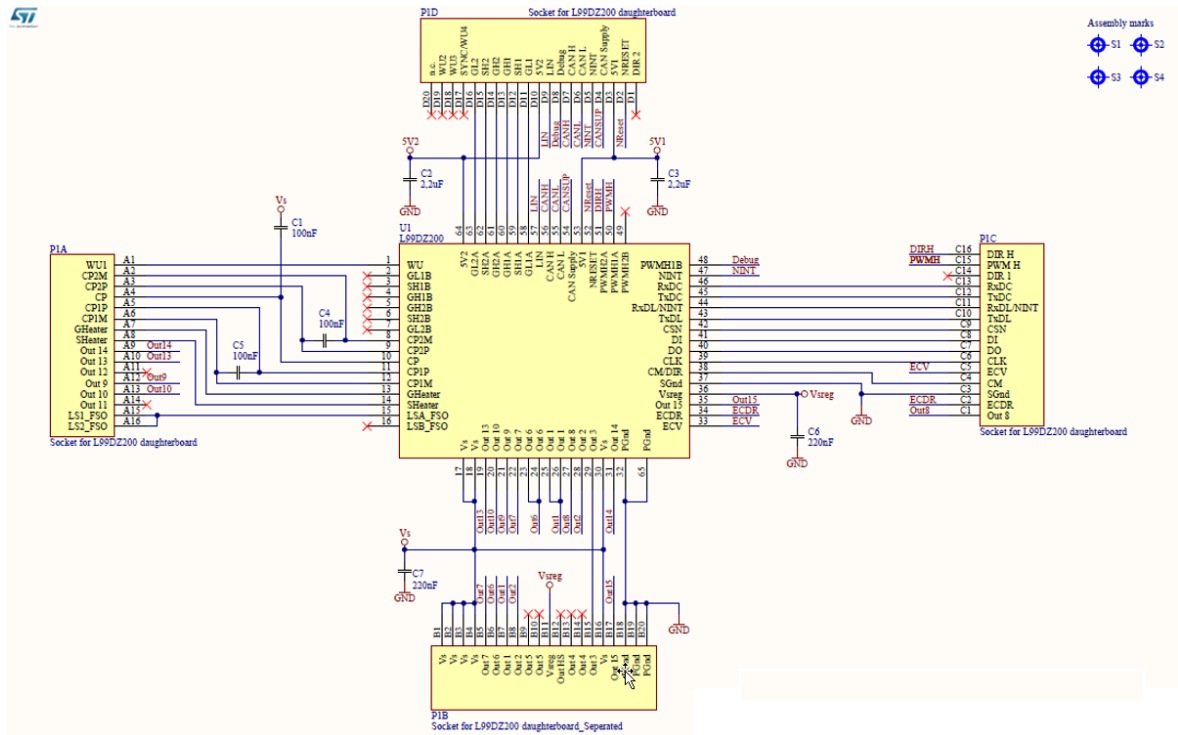
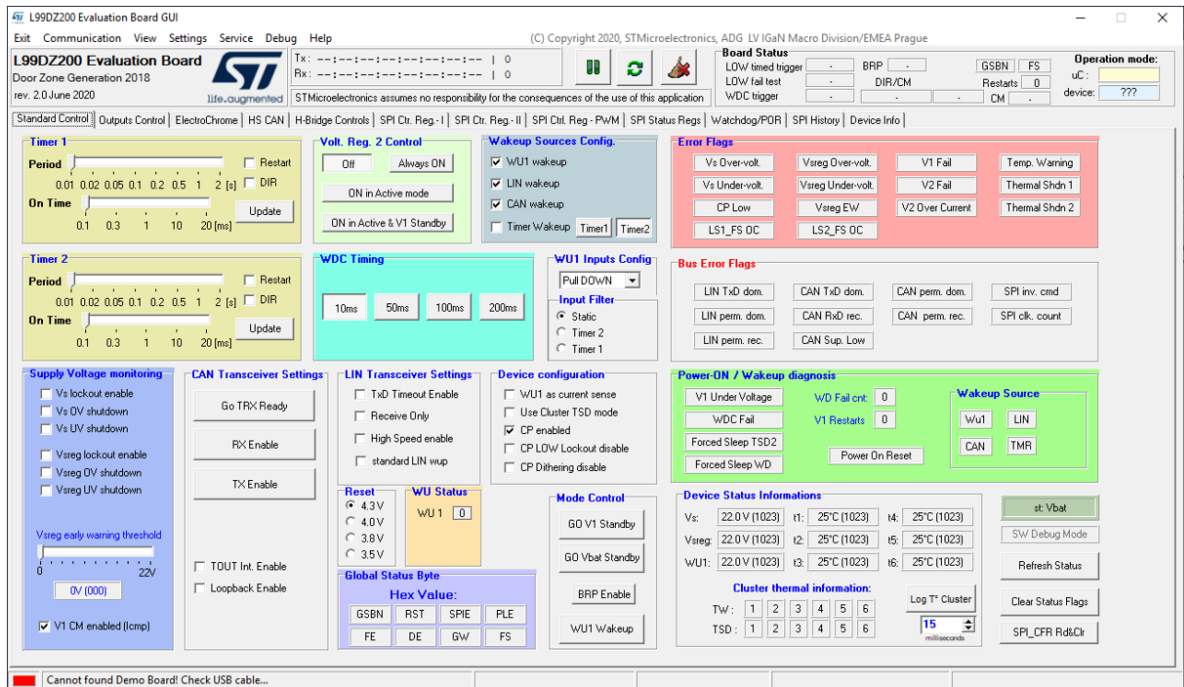

Figure 8. EVAL-L99DZ200 daughter board schematics



## 2 Demonstration software

Figure 9. Main window of EVAL-L99DZ200 graphical user interface





### **3 System requirements**

---

- Windows OS (XP, 7, 8, 10)
- USB type B

## Revision history

**Table 1. Document revision history**

Date	Version	Changes
01-Mar-2021	1	Initial release.

---

## Contents

<b>1</b>	<b>Application schematics and layout</b> .....	<b>2</b>
1.1	Overall application diagram .....	2
1.2	EVAL-L99DZ200 motherboard .....	3
1.3	EVAL-L99DZ200 daughter board .....	6
<b>2</b>	<b>Demonstration software</b> .....	<b>8</b>
<b>3</b>	<b>System requirements</b> .....	<b>9</b>
	<b>Revision history</b> .....	<b>10</b>
	<b>Contents</b> .....	<b>11</b>