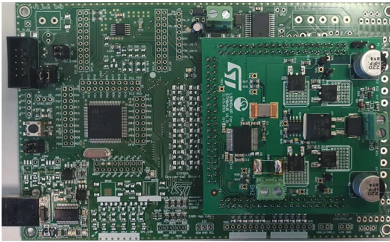


L99H02XP evaluation board



Features

- Operating supply voltage from 6 V to 28 V
- Central 2 stage charge pump 100 % duty cycle
- Full R_{DSon} down to 6 V (normal level MOSFETs)
- Control of reverse battery protection MOSFET
- Charge pump current limited
- PWM operation up to 30 kHz
- SPI interface
- Current sense amplifier/free configurable
- Zero adjust for end of line trimming
- Power management: programmable free-wheeling
- Sensing circuitry of external MOSFETs with embedded thermal sensors

Description

EVAL-L99H02XP is an evaluation board designed for DC motor control in automotive applications. It is composed by a motherboard and a daughterboard on which the L99H02XP is preassembled.

The motherboard, based on STM8A microcontroller, provides the logic section for monitoring and driving the L99H02XP assembled in the daughterboard.

ST provides a dedicated user-friendly software with a Graphic User Interface (GUI), with the aim to make the board usage and settings simpler. This enables the user to set L99H02XP parameters and registers, simultaneously showing real-time device diagnostic information like motor evolution, free-wheeling, board temperature and much more.

Product status link

[EVAL-L99H02XP](#)

Product summary

Order code	EVAL-L99H02XP
Reference	L99H02XP evaluation board

1 Application schematics and layouts

1.1 L99H02XP daughterboard

Figure 1. L99H02XP daughterboard TOP layout

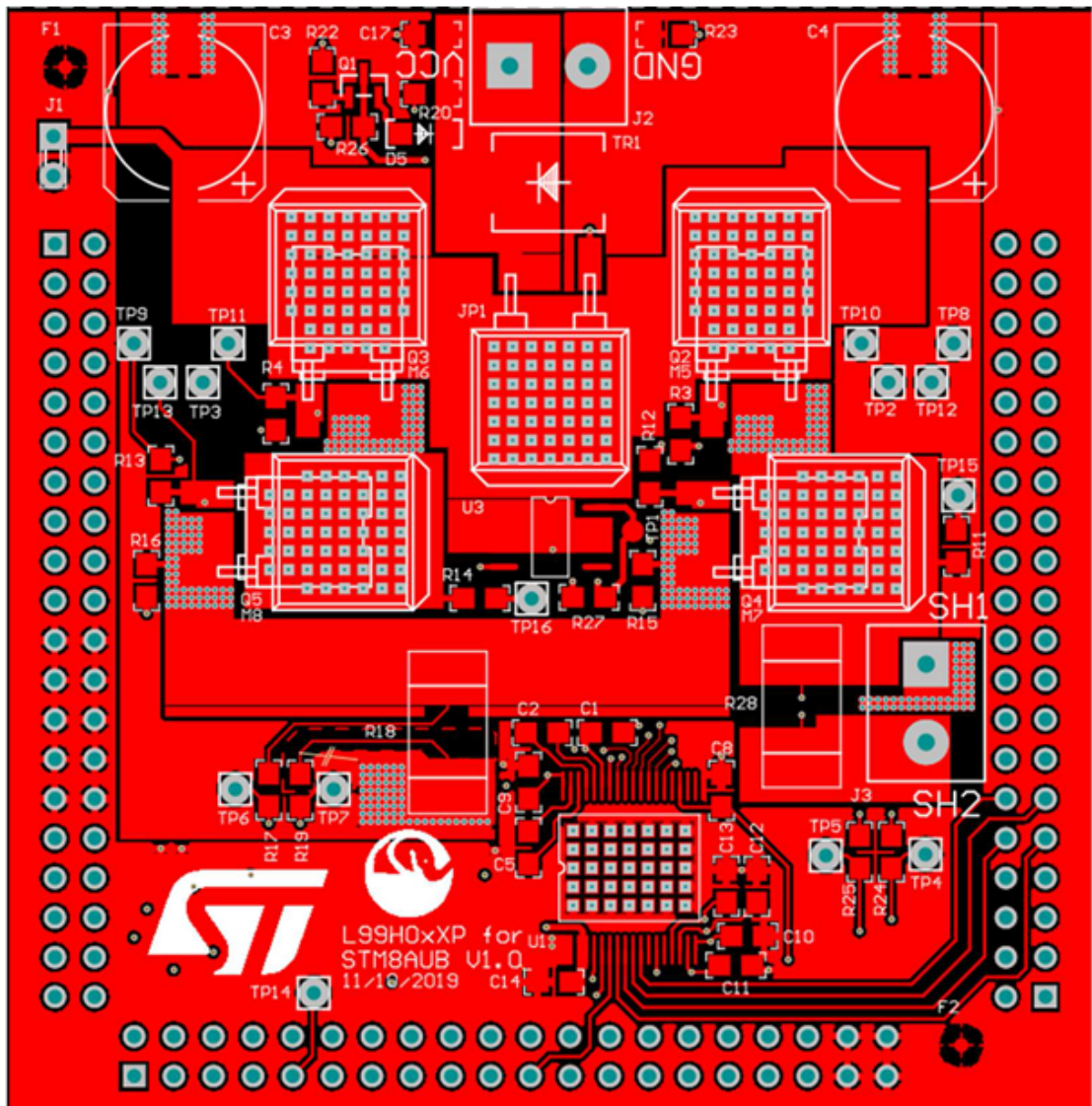


Figure 2. L99H02XP daughterboard MID1 layer

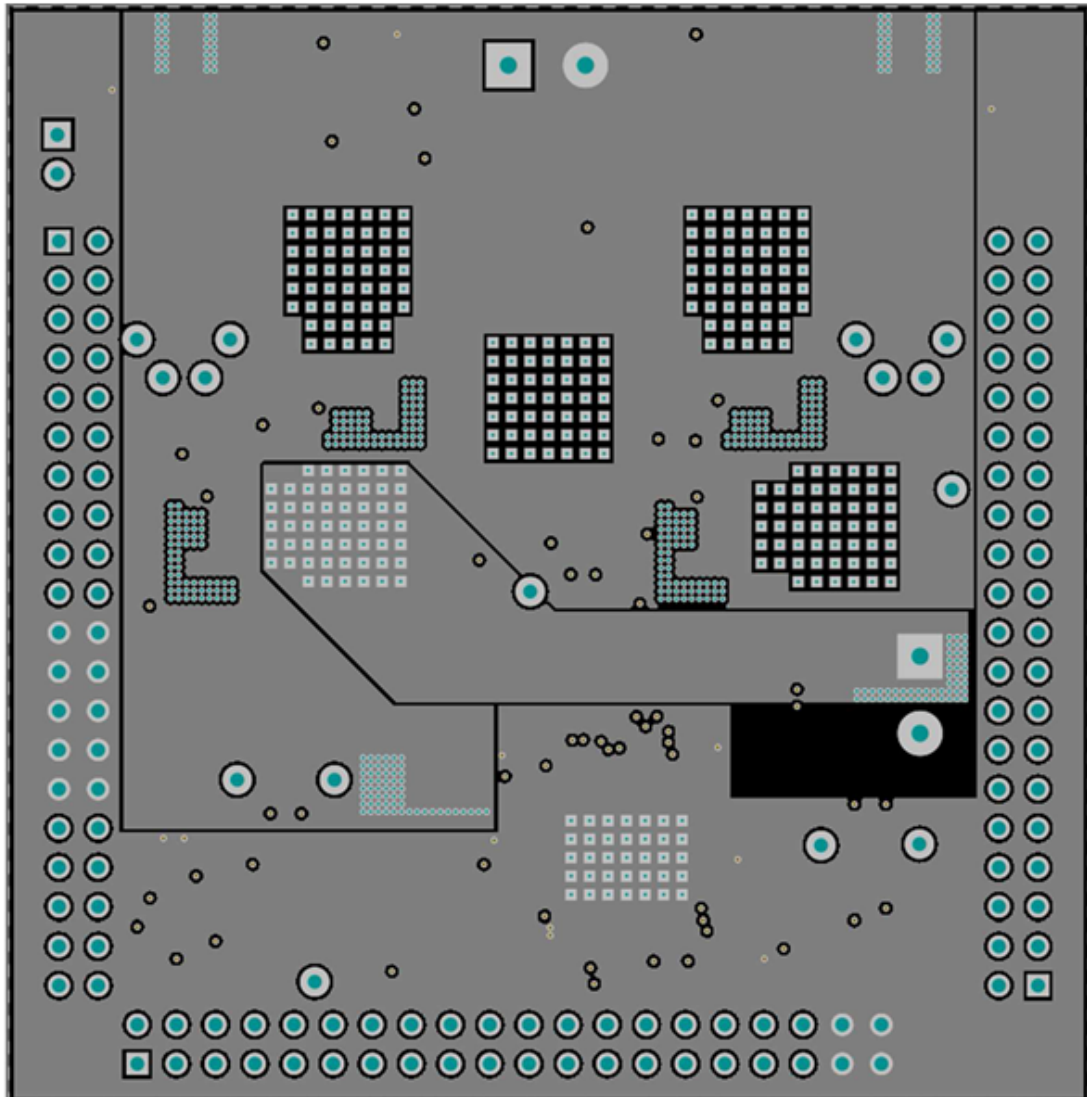


Figure 3. L99H02XP daughterboard MID2 layer

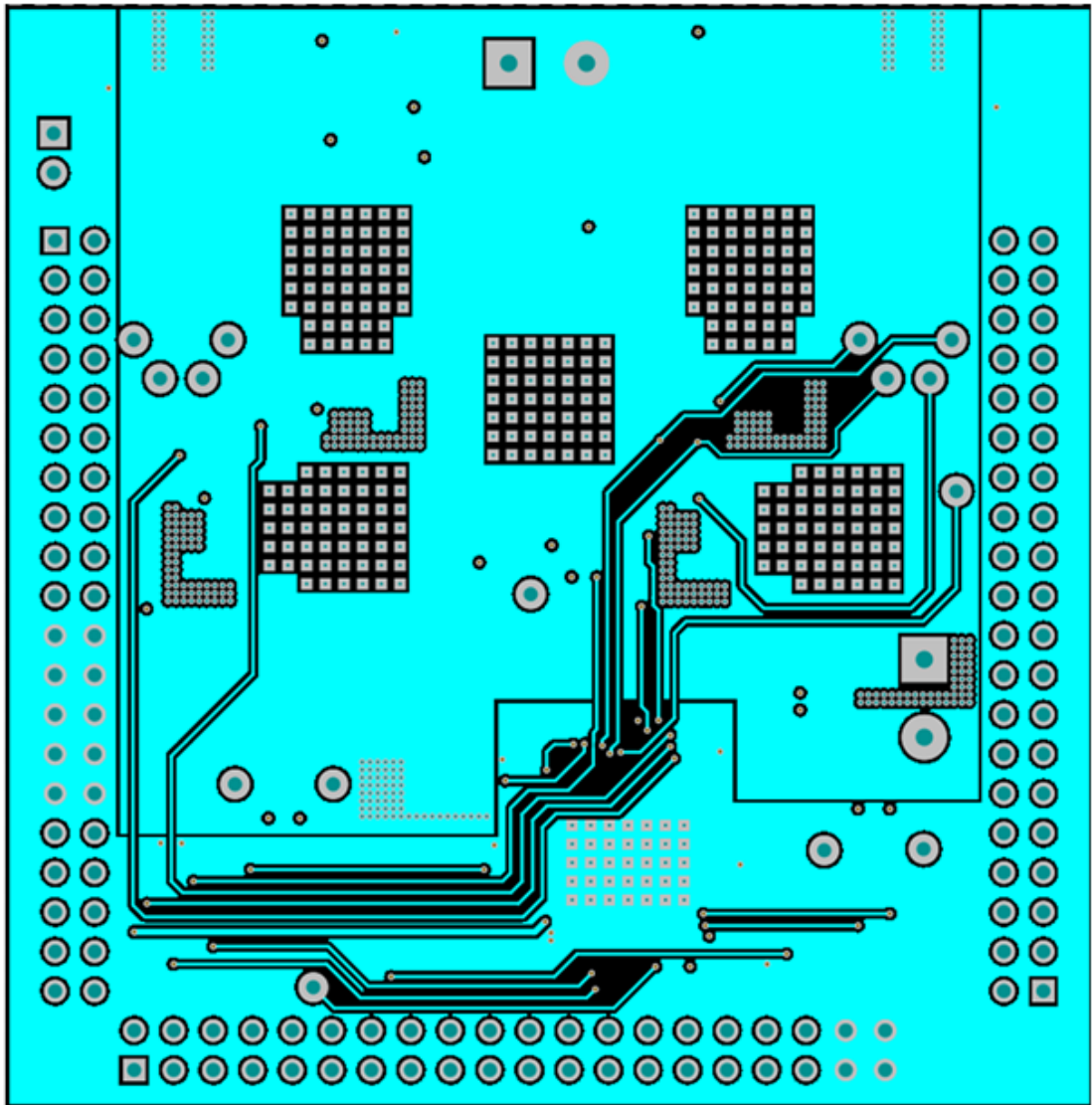


Figure 4. L99H02XP daughterboard bottom layer

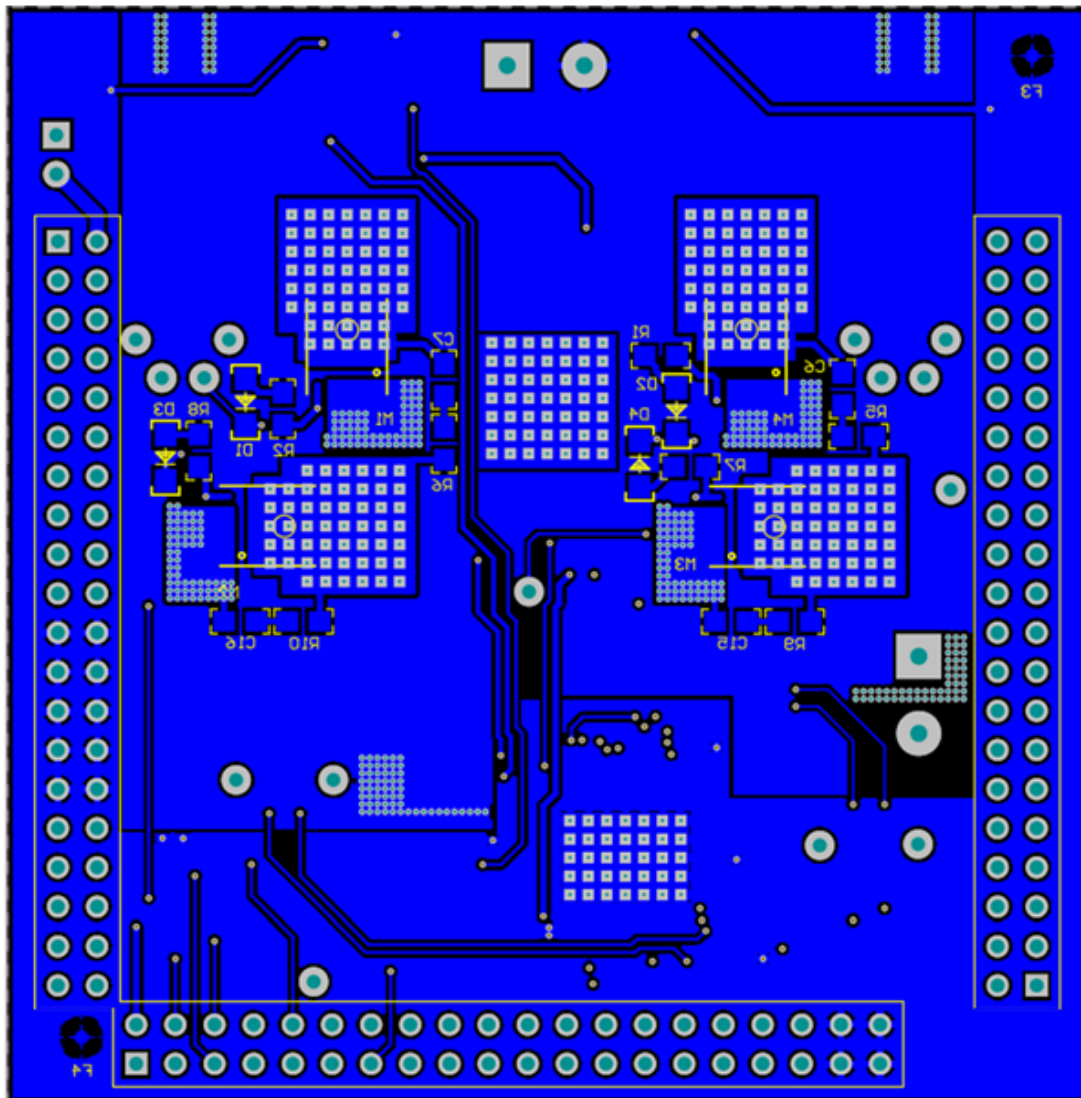
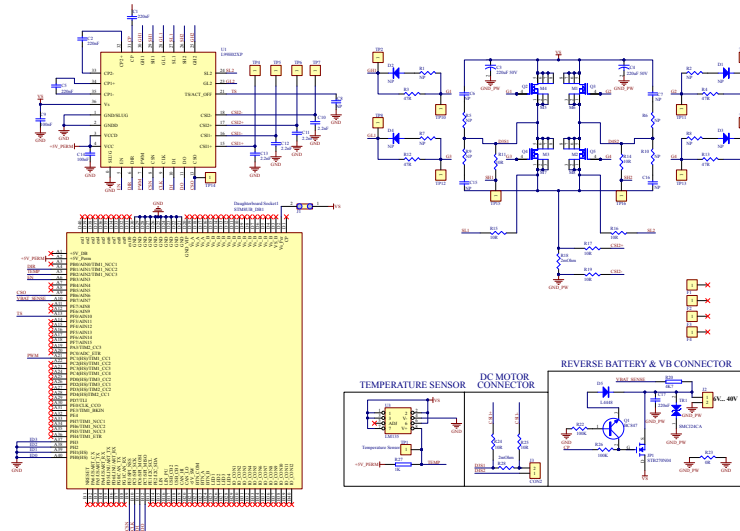


Figure 5. L99H02XP daughterboard application schematic



1.2 STM8 motherboard

Figure 6. STM8 motherboard TOP layer

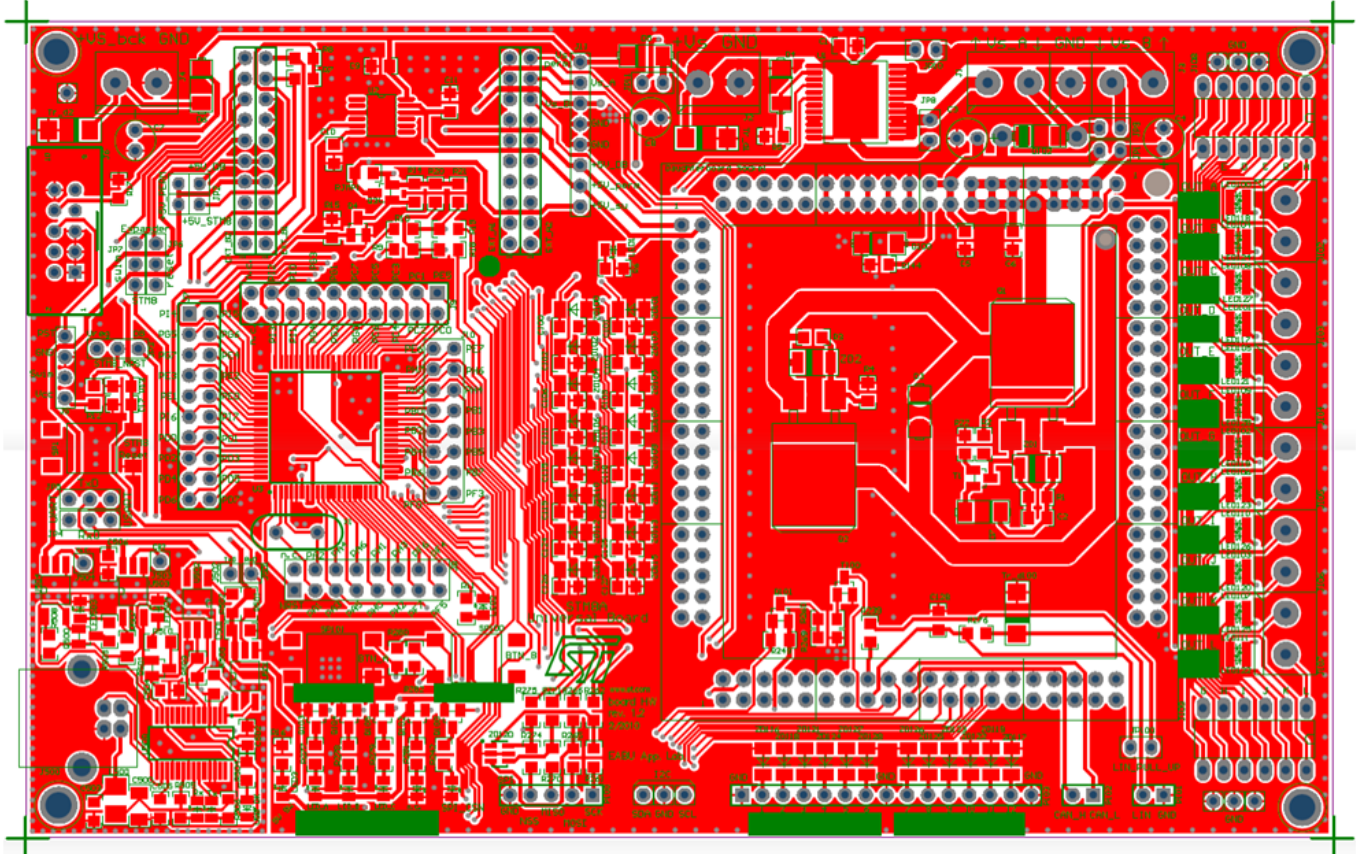


Figure 7. STM8 motherboard bottom layer

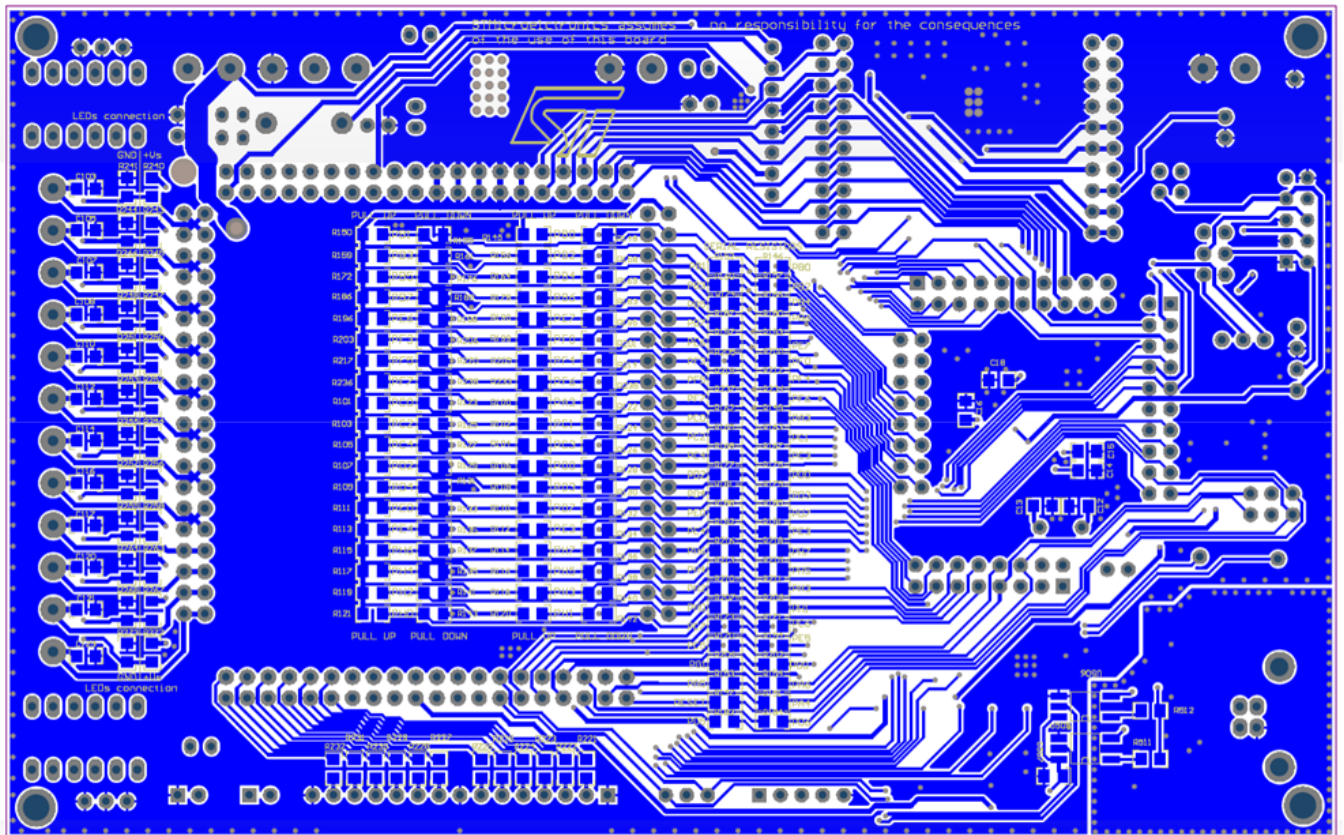


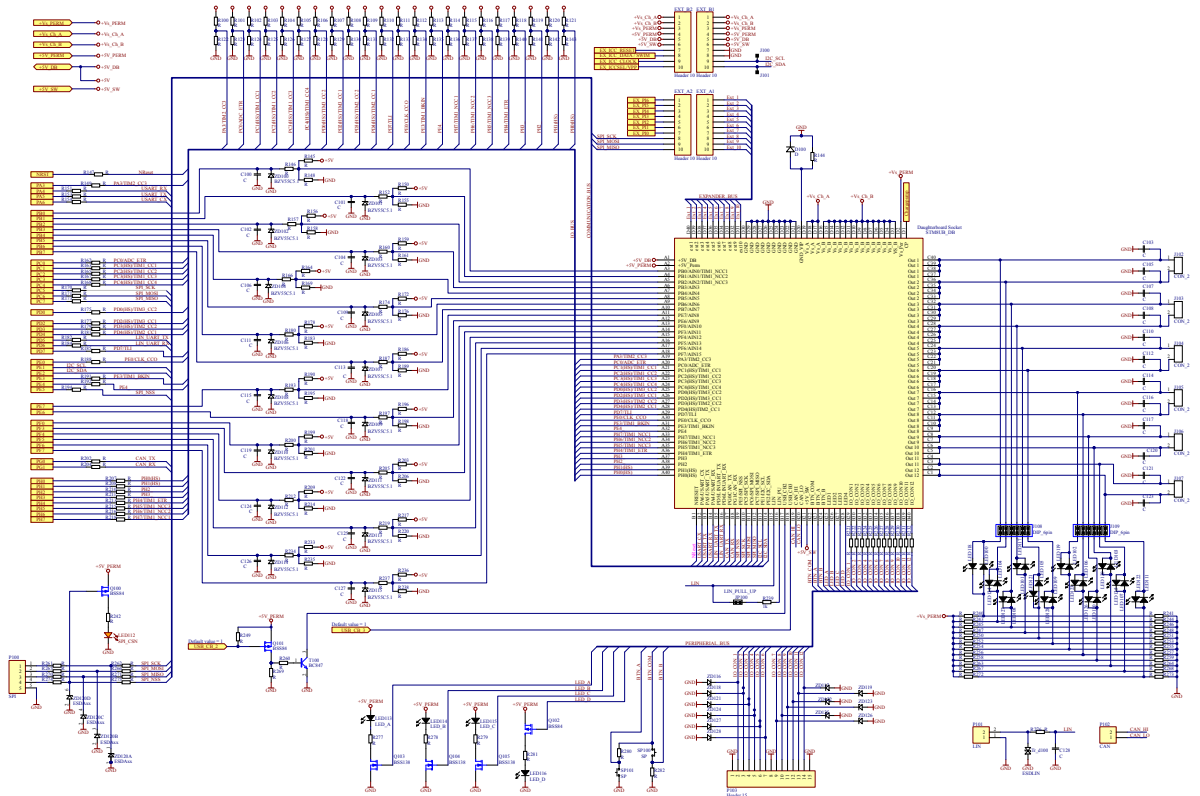
Figure 8. STM8 motherboard – I/O & body application schematic


Figure 9. STM8 motherboard – STM8 & supply application schematic

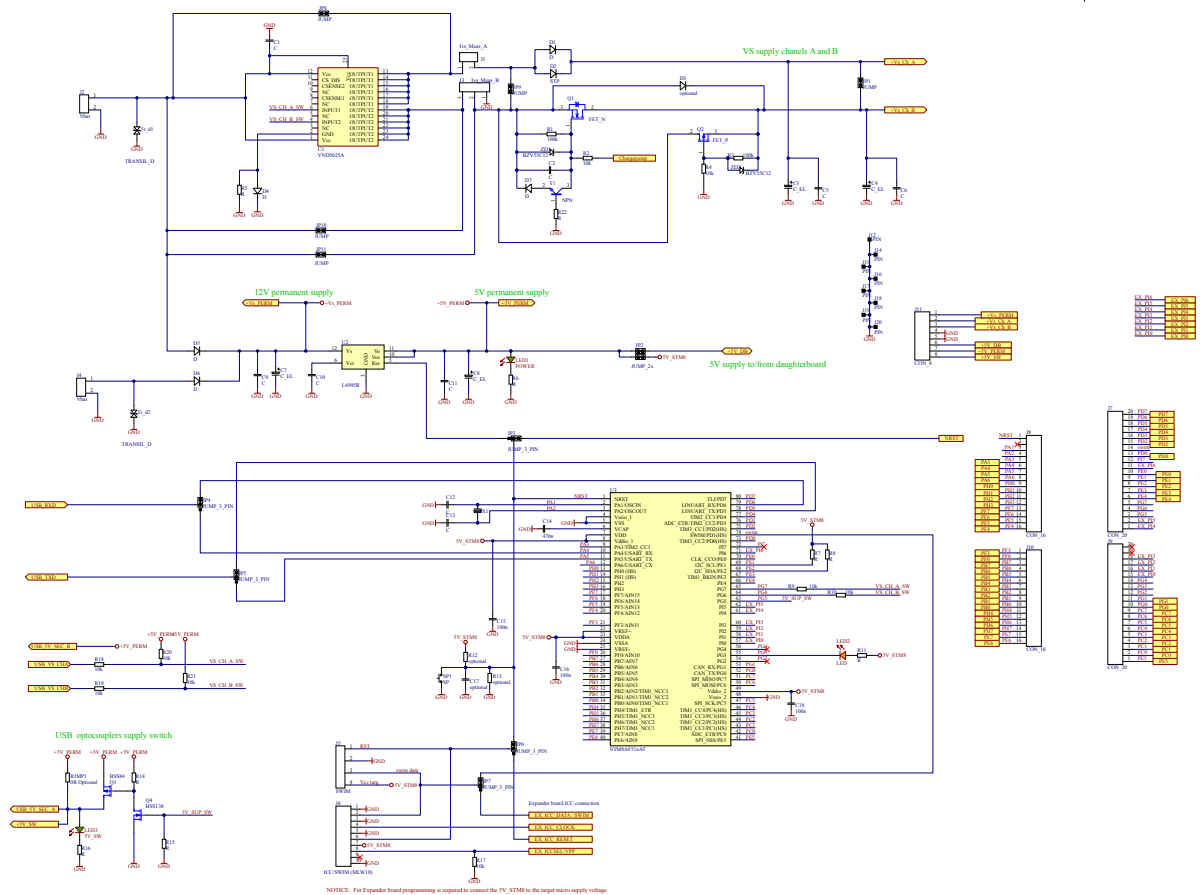
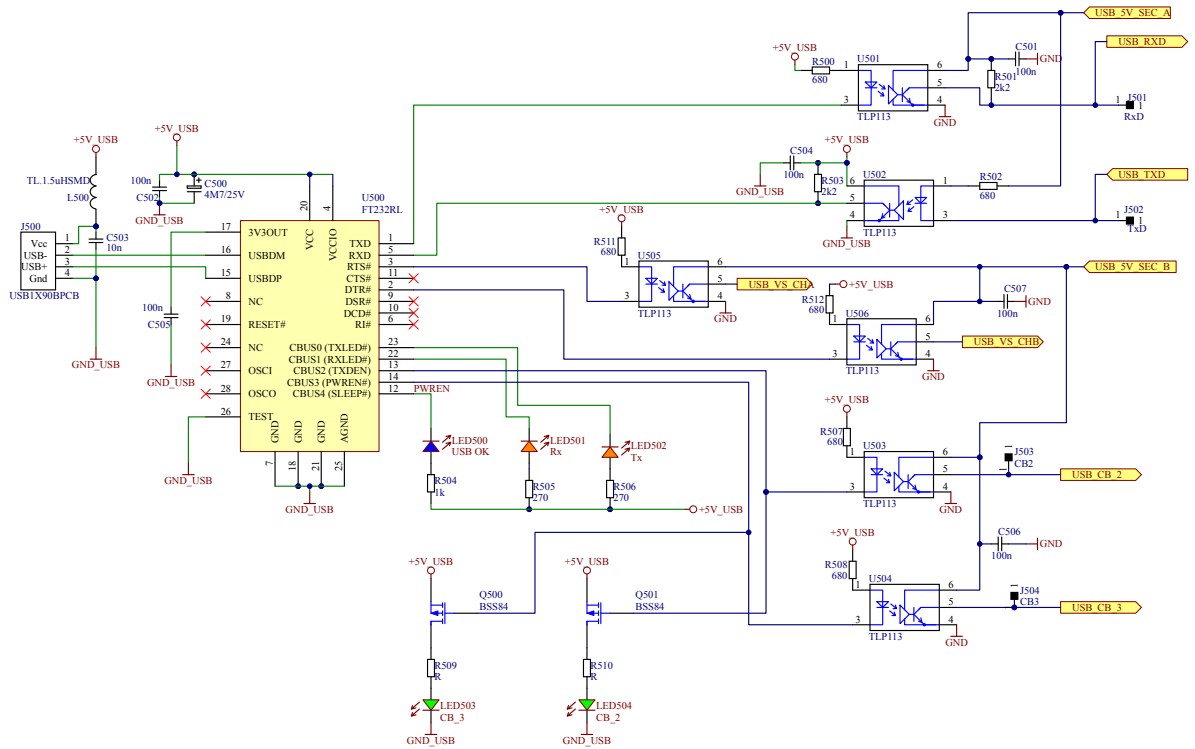


Figure 10. STM8motherboard USB interface application schematic



Revision history

Table 1. Document revision history

Date	Revision	Changes
08-Sep-2021	1	Initial release.
05-Nov-2021	2	Updated rpn in cover page.