

L99MOD5xXP family evaluation kit for automotive applications



Features

- MOSFET and diode reverse battery protection network
- Possibility of powering at 12 V through daughterboard connector
- Half-bridge and high-side outputs available depending on the specific device

Applications

- Multiple **brushed DC motors** and additional loads in high-side configuration, such as bulbs, LEDs or protected supply

Description

The EVAL-L99MOD5xXP evaluation kit consists in a motherboard and a daughterboard on which the L99MOD5xXP device is assembled. Both of these evaluation boards provide electronic control modules with enhanced power management functionalities including a standby mode.

The motherboard, based on the SPC56 microcontroller, provides the logic section for driving and monitoring the L99MOD5xXP device assembled on the daughterboard.

With the aim of facilitating the use and configuration of the board, ST provides a dedicated user-friendly software with a graphic user interface (GUI) which can be downloaded from STMicroelectronics's website.

The GUI enables the user to set the L99MOD5xXP parameters and get real time information from the device, such as registers status, analog current sense, fault flags and much more.

Product status links

EVAL-L99MOD5xXP family

[EVAL-L99MOD50XP](#)

[EVAL-L99MOD51XP](#)

[EVAL-L99MOD53XP](#)

[EVAL-L99MOD54XP](#)

1 Application schematics and layout

Figure 1. EVAL-L99MOD5xXP top layer and Figure 2. EVAL-L99MOD5xXP bottom layer show the top and bottom layer of the L99MOD5xXP daughterboard.

Figure 3. EVAL-L99MOD5xXP schematic shows the EVAL-L99MOD5xXP schematic.

Figure 1. EVAL-L99MOD5xXP top layer

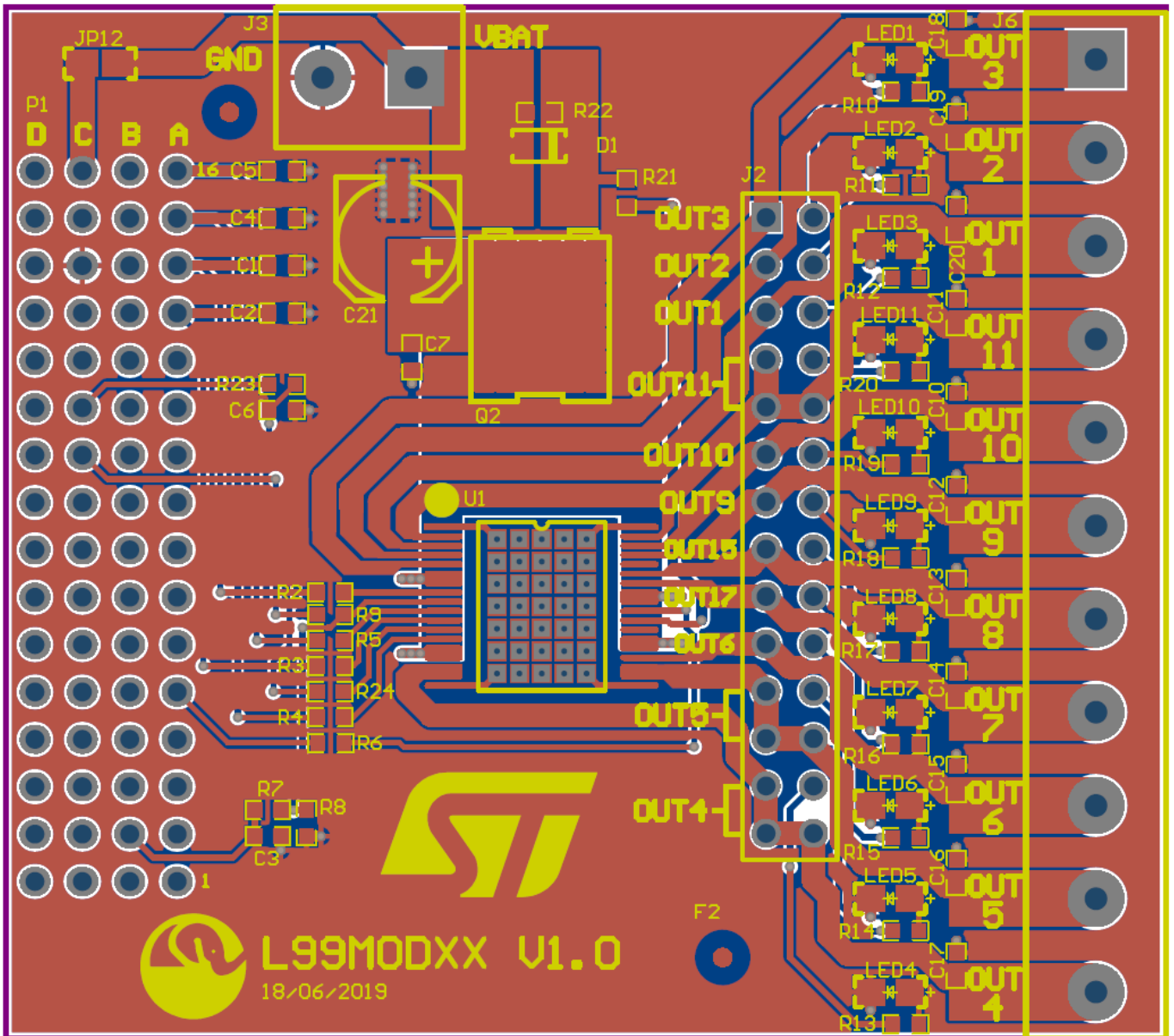

Figure 2. EVAL-L99MOD5xXP bottom layer

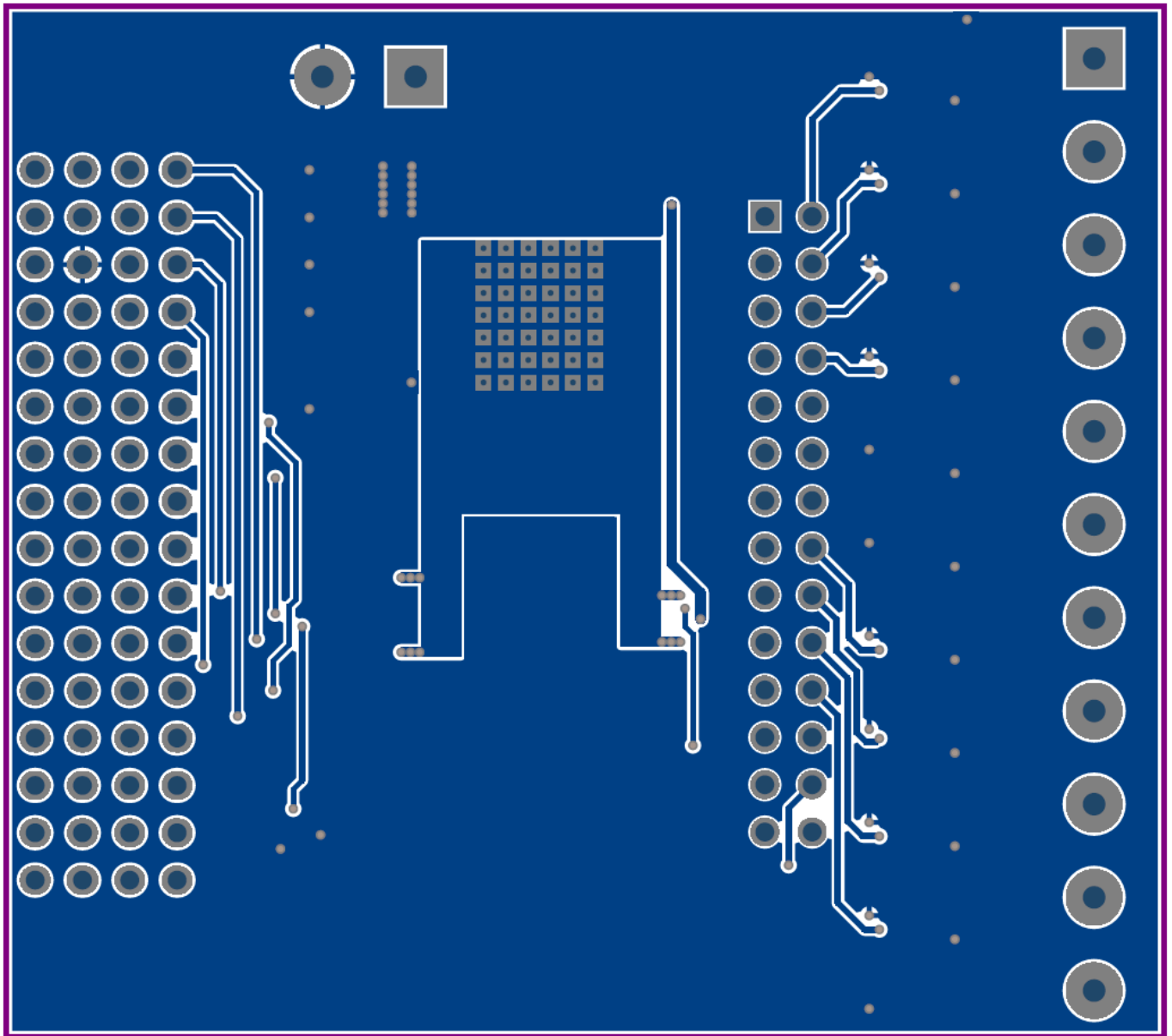
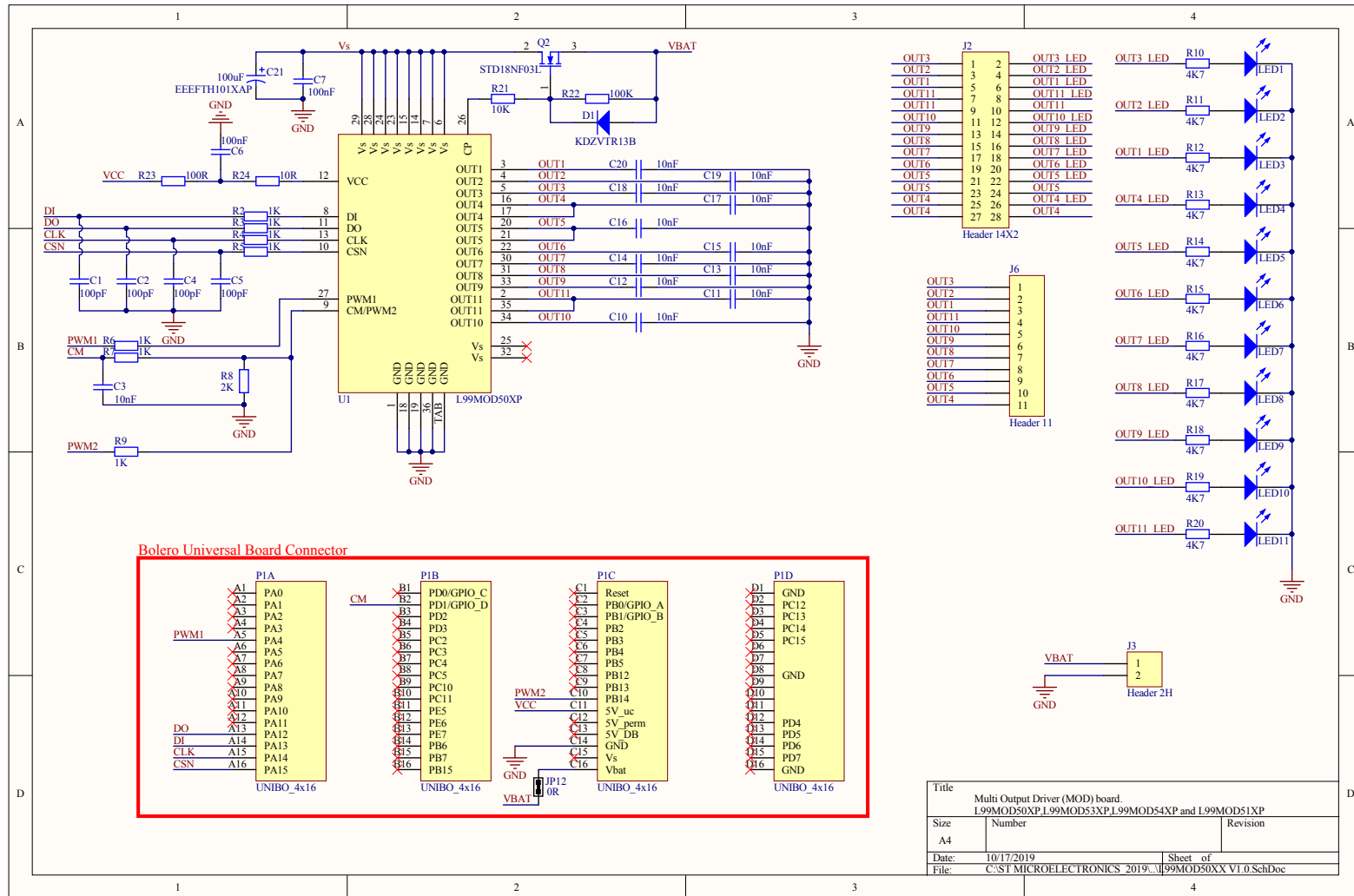

Figure 3. EVAL-L99MOD5xXP schematic



| | | |
|---|--|----------|
| Title | | |
| Multi Output Driver (MOD) board. L99MOD50XP.L99MOD53XP.L99MOD54XP and L99MOD51XP | | |
| Size | Number | Revision |
| A4 | | |
| Date: | 10/17/2019 | Sheet of |
| File: | C:\ST MICROELECTRONICS\2019\199MOD50XX V1.0.SchDoc | |



2 Demonstration software

A software graphical user interface (GUI) for easy demonstration of the L99MOD5xXP features is available for download on www.st.com, under product code **STSW-L99MOD5xXP**.

To use the demonstration software, it is necessary to download and install the VISA and LabVIEW Run-Time Engine software from the supplier's website.

3 System requirements

- Windows OS (XP, 7, 8, 10)
- USB port

4 Ordering information

Table 1. Ordering information

| Part number | Order code | Reference |
|-----------------|-----------------|-------------------------------|
| EVAL-L99MOD50XP | EVAL-L99MOD50XP | L99MOD50XPTR evaluation board |
| EVAL-L99MOD51XP | EVAL-L99MOD51XP | L99MOD51XPTR evaluation board |
| EVAL-L99MOD53XP | EVAL-L99MOD53XP | L99MOD53XPTR evaluation board |
| EVAL-L99MOD54XP | EVAL-L99MOD54XP | L99MOD54XPTR evaluation board |

Revision history

Table 2. Document revision history

| Date | Version | Changes |
|-------------|---------|----------------|
| 20-Nov-2019 | 1 | First release. |