

## L99SM81V evaluation board



### Features

- Bipolar stepper motor driving through L99SM81V device
- MOSFET reverse battery protection, with the possibility to replace it with two diodes through dedicated jumper configuration
- ISO pulse protection (not soldered)
- Normally powered at 12 V through a specific daughterboard connector
- Possibility to solder output capacitors at the motor terminals
- L99SM81V internal 5 V linear voltage regulator output connector available on the daughterboard
- The motherboard allows selecting the digital power supply of the L99SM81V between 5 V and 3.3 V through a dedicated jumper

### Description

The [EVAL-L99SM81VY](#) is an evaluation board designed to drive one bipolar stepper motor in micro-stepping mode together with coil voltage measurement for stall detection. The evaluation board consists in a motherboard and a daughterboard on which the L99SM81V is mounted. Both of the evaluation boards provide electronic control modules with enhanced power management power supply functionalities including one standby mode.

The motherboard, based on SPC56 microcontroller, provides the logic section for monitoring and driving the L99SM81V assembled on the daughterboard.

With the aim of making the board usage and settings simpler, ST provides dedicated user-friendly software with a Graphic User Interface (GUI). This enables the user to set L99SM81V parameters and at the same time to get real time information from the device, such as voltage measurements, main power supply voltage, fault flags, device junction temperature and much more.

Product summary	
Order code	<a href="#">EVAL-L99SM81VY</a>
Reference	L99SM81V evaluation board

# 1 Application schematics and layouts

## 1.1 EVAL-L99SM81VY daughterboard

Figure 1. EVAL-L99SM81VY top layer

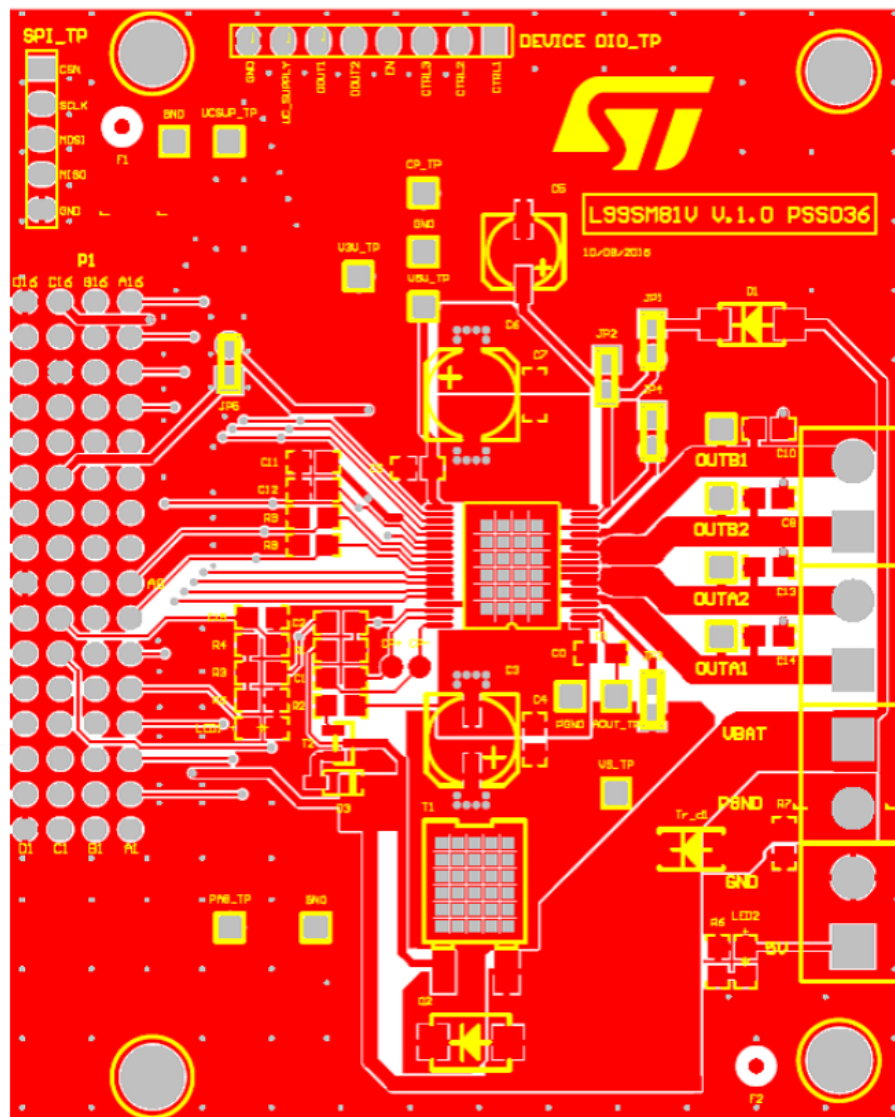
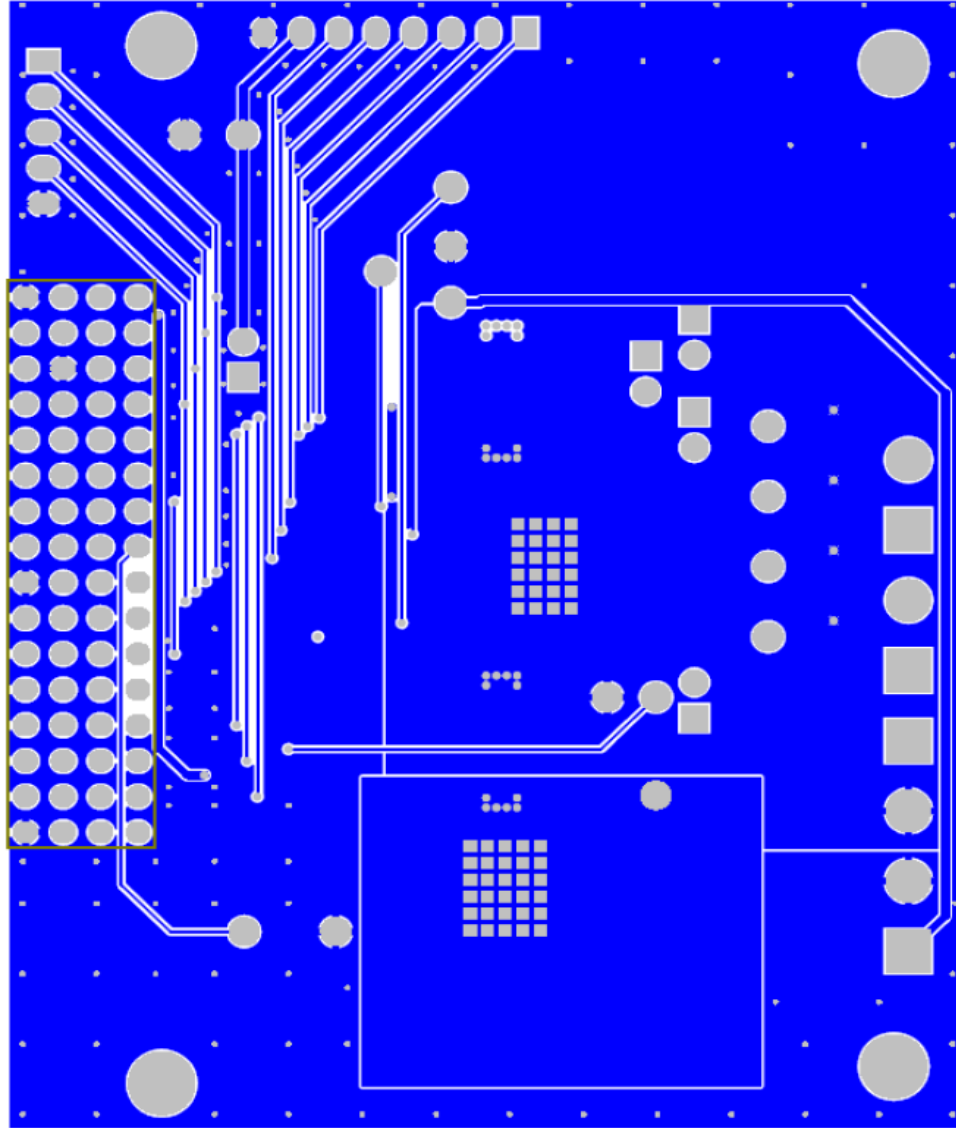
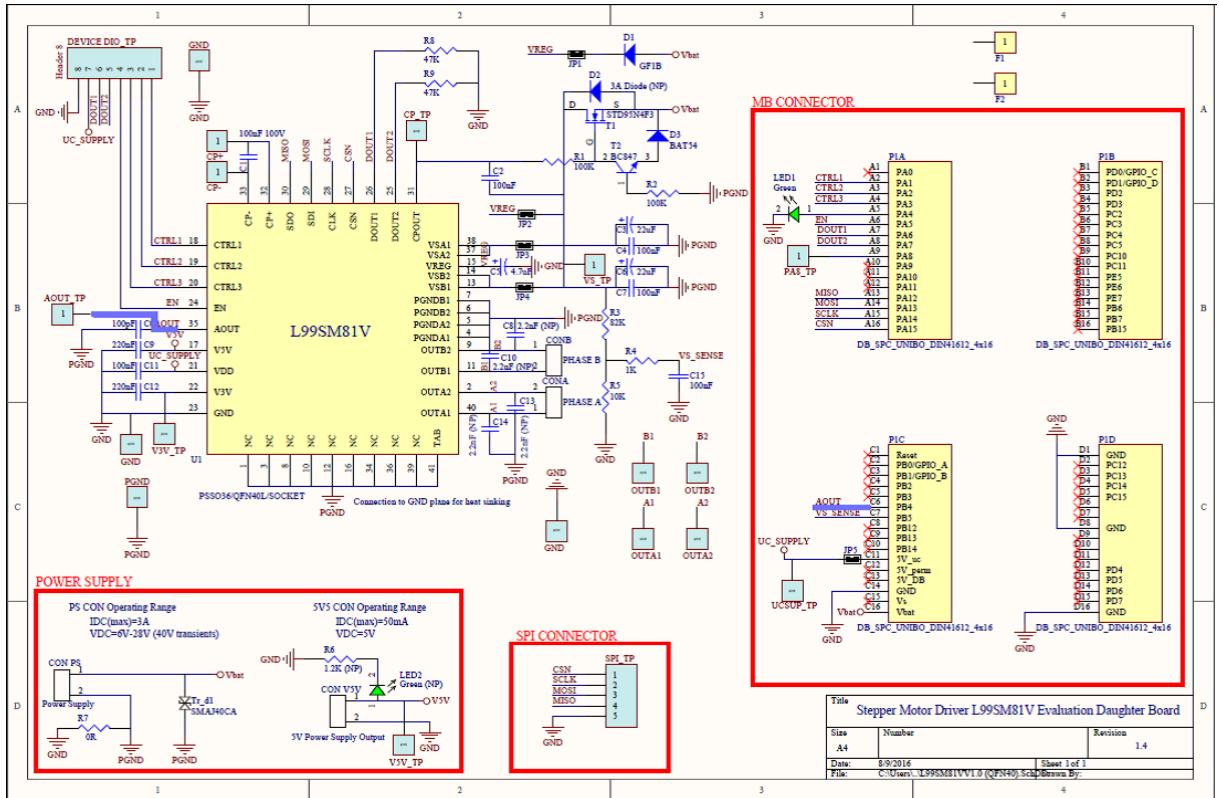

Figure 2. EVAL-L99SM81VY bottom layer



## 1.2 EVAL-L99SM81VY schematic

Figure 3. EVAL-L99SM81VY schematic



## 2 Demonstration software

---

A software GUI (Graphical User Interface) for easy demonstration of the L99SM81VY can be downloaded from [ST.com](http://ST.com).

### 2.1 System requirements

- Windows OS (XP, 7, 8)
- USB type B

## Revision history

**Table 1. Document revision history**

Date	Version	Changes
13-Dec-2018	1	Initial release.