

General Description

Evaluation board EVAL-LT8374-1-AZ is a synchronous step-down LED driver featuring the LT[®]8374-1. It drives up to 15V of LEDs at 1A when the EMIVIN terminal is between 18V and 47V. EVAL-LT8374-1-AZ runs at 2MHz switching frequency and features options for spread-spectrum frequency modulation (SSFM) or external synchronization.

The LT8374-1 has an input voltage range of 6.5V to 60V. It features 60V synchronous internal power switches for high efficiency and small solution size. The switching frequency of LT8374-1 is fixed at 2MHz, and the device can be synchronized with an external clock source or configured with internal SSFM for low EMI. With SSFM enabled, the LT8374-1 modulates its switching frequency between 2MHz and 2.5MHz to reduce switching emissions. EVAL-LT8374-1-AZ includes a SYNC/SSFM jumper to configure the LT8374-1 for either external synchronization, SSFM, or set to normal operation.

The LT8374-1 can be analog dimmed by applying a DC voltage between 1.25V and 250mV to the CTRL pin. An internal 20 μ A current source allows for a single resistor connected between the CTRL pin and GND to provide this voltage. Alternatively, the LT8374-1 can be analog dimmed by applying a 15kHz to 200kHz PWM signal with a duty cycle between 12.5% to 62.5% to the CTRL pin. For higher-resolution LED brightness control, a 100Hz to 200Hz PWM signal can be applied to the CTRL pin.

Small ceramic input and output capacitors are used to save space and cost. This evaluation board is designed with high frequency capacitors placed close to the IC's VIN pins to form a compact switching hotloop for best EMI performance. Ferrite bead filters placed at the input and output help further reduce switching emissions. For best

efficiency, the EMI filters at the input and output can be removed. Follow the recommended layout and the four-layer PCB thickness of EVAL-LT8374-1-AZ for optimal performance.

The LT8374-1 features overvoltage protection (OVP) which uses the IC's constant voltage regulation loop to regulate the output to approximately 20V in the case of an OPENLED event. A single resistor connecting VOUT to FB provides this regulation setpoint. Both LED current and output overvoltage protection (OVP) can all be adjusted with simple modifications to EVAL-LT8374-1-AZ.

The LT8374-1 also features optional internal compensation options for reduced component-count designs. To utilize the internal compensation options, the external compensation components must be removed, and the VC pin must be left floating. With external compensation components removed, the CAP pin can either be left floating or connected to GND to select between the two internal compensation options. EVAL-LT8374-1-AZ is configured with an optimized external compensation network by default and includes a jumper for selecting between the two internal and external compensation configurations.

The LT8374-1 data sheet gives a complete description of the device, its operation, and applications information. The data sheet must be read in conjunction with this demo manual for the evaluation board EVAL-LT8374-1-AZ. The LT8374-1 is assembled in a 16-lead plastic QFN package with a thermally enhanced exposed ground pad. The proper board layout is essential for maximum performance. Refer to the "Designing the Printed Circuit Board" section in the data sheet.

Design files for this circuit board are available.

Performance Summary

Specifications are at $T_A = 25^\circ\text{C}$

PARAMETER	CONDITIONS	MIN	TYP	MAX	UNITS
EMIVIN Input Voltage Range	Operating	18		47	V
Switching Frequency (f_{SW})	JP1 = NO SSFM/SYNC		2000		kHz
	JP1 = SSFM ON	2000		2500	kHz
LED Current (I_{LED})	R1 = 0.1 Ω , 18V < EMIVIN < 47V, $V_{LED} \leq 15V$		1		A
OPENLED Voltage (V_{OVP})	R9 = 316k		20		V
Typical Efficiency	EMIVIN = 24V, $V_{LED} = 15V$, $I_{LED} = 1A$		91		%

Quick Start Procedure

Demonstration circuit EVAL-LT8374-1-AZ is easy to set up to evaluate the performance of the LT8374-1. See [Figure 1](#) for proper measurement equipment setup and use the following procedure:

1. With power off, connect an input power supply between the EMIVIN and GND turrets. Connect a string of LEDs that will run with forward voltage less than or equal to 15V at 1A between the LED+ and LED- turrets on the PCB as shown in [Figure 1](#).
2. Set the JP2 jumper to EXT COMP to enable the external compensation components populated on EVAL-LT8374-1-AZ. To use internal compensation settings, external components must be removed.
3. Set the JP1 to NO SSFM/SYNC to run at 2MHz fixed switching frequency or to SSFM ON for 2MHz to 2.5MHz modulated switching frequency for improved in EMI performance.
4. Turn the input power supply and slowly increase the voltage to 24V
 - Note: Ensure that the input voltage applied to EVAL-LT8374-1-AZ is always within the range specified in the performance summary table.
5. Observe the LED string running at the programmed LED current of 1A.
6. LED brightness can be adjusted by applying a voltage at the CTRL turret.

ANALOG DIMMING (Method 1): Applying a DC voltage between 0.25V and 1.25V to the CTRL pin will adjust the DC level of the LED current. Refer to the ‘LED Current (Analog CTRL)’ in the Typical Performance Characteristics section of the LT8374-1 data sheet for the relationship of $V_{(ISP-ISN)}$ to V_{CTRL} . An internal 20µA current source allows for a single resistor from the CTRL pin to GND to set V_{CTRL} . Up to 20:1 Analog Dimming advised.

ANALOG DIMMING (Method 2): Applying an external PWM signal between 15kHz to 200kHz with a variable duty cycle from 12.5% to 62.5% to the CTRL pin will adjust the DC level of the LED current. Refer to ‘LED Current (Digital CTRL)’ in the Typical Performance Characteristics of the LT8374-1 data sheet for the relationship of $V_{(ISP-ISN)}$ to the CTRL duty cycle. Up to 20:1 Analog Dimming advised.

PWM DIMMING: Applying an external PWM signal under 10kHz with a variable duty cycle to the CTRL pin to allow the LED brightness to be controlled by delivering pulses of current to the LEDs. Lower PWM dimming frequencies allow for higher achievable dimming ratios while maintaining output regulation. EVAL-LT8374-1-AZ can achieve up to 1000:1 dimming ratios with a 100Hz PWM dimming signal.

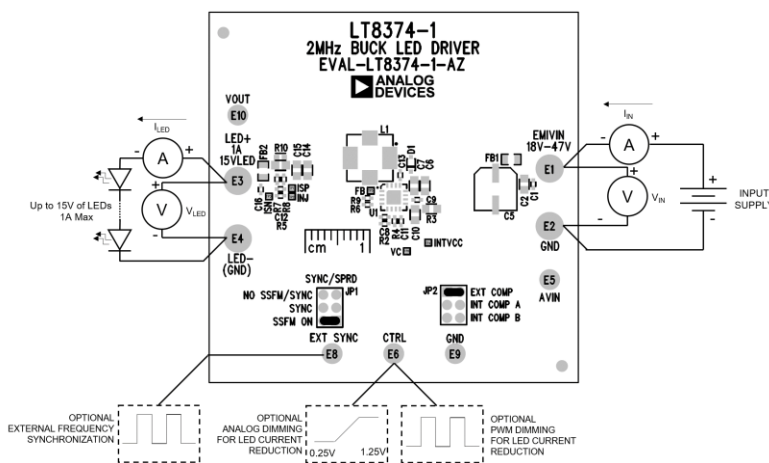

Figure 1. EVAL-LT8374-1-AZ Board Connections

Table 1. SYNC/SPRD Jumper (JP1) Setting

SHUNT POSITION	SYNC/SPRD PIN CONNECTION	SWITCHING FREQUENCY
1-2*	INTV _{CC}	SSFM ON
3-4	External Connection	EXTERNAL SYNC
5-6	GND	No SYNC / SSFM OFF

*Default position

Table 2. Compensation Jumper (JP2) Setting

SHUNT POSITION	CAP PIN CONNECTION	COMPENSATION SELECTION
1-2*	INTV _{CC}	External Compensation Network
3-4	Floating	Internal Compensation (28k + 1nF)
5-6	GND	Internal Compensation (19k + 220pF)

*Default position

Typical Performance

(V_{IN} = 24V, V_{LED} = 15V, I_{LED} = 1A, SSFM = ON, T_A = 25°C, unless otherwise noted.)

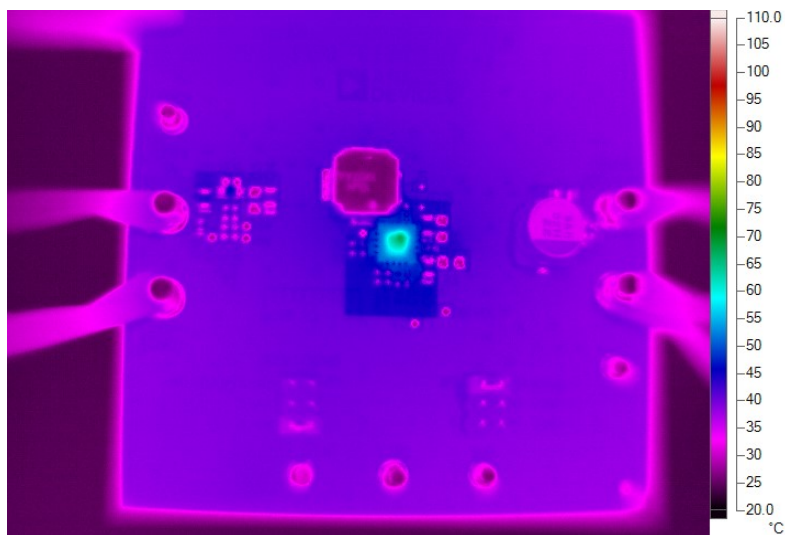

Figure 2. Evaluation Board Thermal Image

Typical Performance

($V_{IN} = 24V$, $V_{LED} = 15V$, $I_{LED} = 1A$, SSFM = ON, $T_A = 25^\circ C$, unless otherwise noted.)

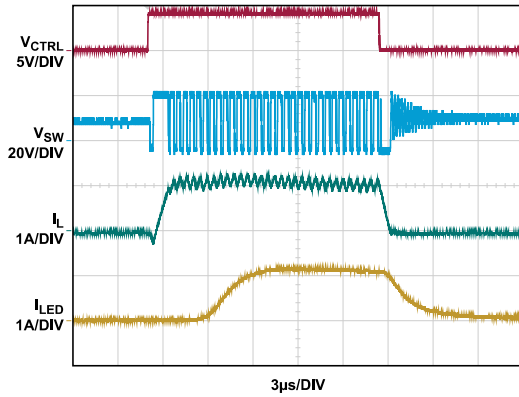

Figure 3. External PWM Dimming

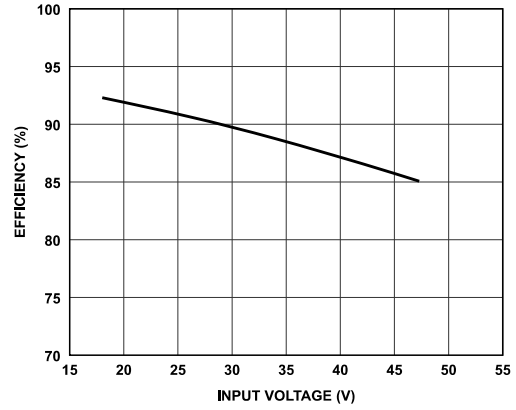

Figure 4. Efficiency vs. Input Voltage

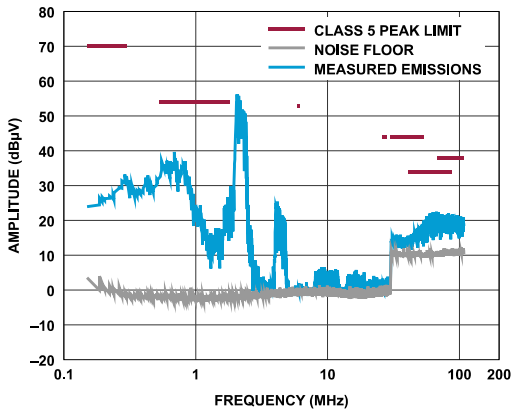

Figure 5. Peak Conducted Emissions (Voltage Method)

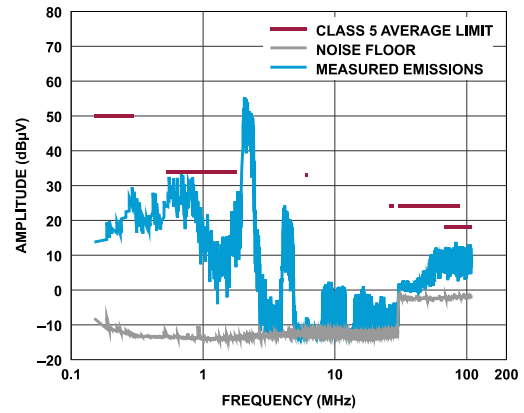

Figure 6. Average Conducted Emissions (Voltage Method)

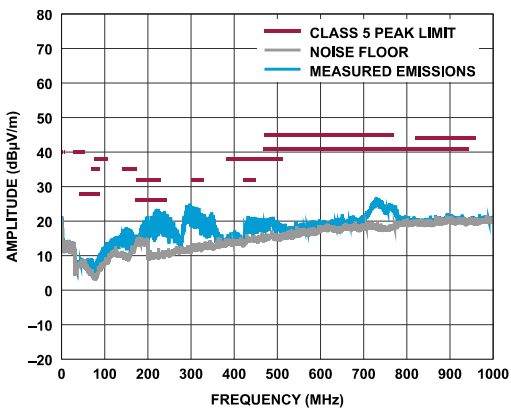

Figure 7. Peak Radiated Emissions (ALSE Method)

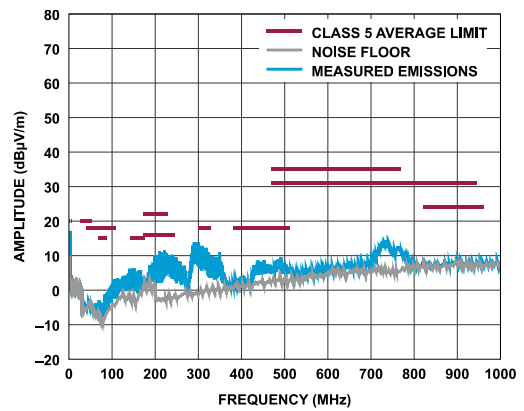

Figure 8. Average Radiated Emissions (ALSE Method)

Bill of Materials

ITEM	QTY	REFERENCE	DESCRIPTION	MANUFACTURER PART #
REQUIRED CIRCUIT COMPONENTS				
1	1	C7	CAP., 4.7 μ F, X5R, 50V, 10%, 0805, AEC-Q200	TDK, CGA4J3X5R1H475K125AB
2	1	C9	CAP., 2.2 μ F, X5R, 6.3V, 20%, 0402, AEC-Q200	TAIYO YUDEN, JMK105BJ225MVHF
3	1	C10	CAP., 1 μ F, X7R, 50V, 10%, 0805, AEC-Q200	MURATA, GCM21BR71H105KA03L
4	1	C11	CAP., 47pF, C0G/NP0, 50V, 5%, 0402, AEC-Q200	MURATA, GCM1555C1H470JA16D
5	1	C13	CAP., 0.022 μ F, X7R, 25V, 10%, 0402, AEC-Q200	MURATA, GCM155R71E223KA55D
6	1	C14	CAP., 2.2 μ F, X7R, 25V, 10%, 0805, AEC-Q200	TDK, CGA4J3X7R1E225K125AB
7	1	L1	IND., 10 μ H, PWR, SHIELDED, 20%, 4A, 76.9m Ω , 2525CD, IHLE-5A Series, AEC-Q200	VISHAY, IHLE2525CDER100M5A
8	1	R4	RES., 10k Ω , 1%, 1/16W, 0402, AEC-Q200	VISHAY, CRCW040210K0FKED
9	1	R9	RES., 316k Ω , 1%, 1/16W, 0402, AEC-Q200	VISHAY, CRCW0402316KFKED
10	1	R10	RES., 0.10 Ω , 1%, 1/2W, 0805, AEC-Q200	PANASONIC, ERJ6DSFR10V
11	1	U1	IC, LED DRIVER CTRLR, QFN-16	ANALOG DEVICES, INC., LT8374RUFM-1#WPBF
OPTIONAL EMI FILTER COMPONENTS				
12	1	C1	CAP., 0.1 μ F, X7R, 50V, 10%, 0402, AEC-Q200	MURATA, GCM155R71H104KE02D
13	1	C2	CAP., 1 μ F, X7R, 50V, 10%, 0805, AEC-Q200	MURATA, GCM21BR71H105KA03L
14	1	C5	CAP., 22 μ F, ALUM POLY HYB, 50V, 20%, 6.3x5.8mm, SMD, RADIAL, AEC-Q200	PANASONIC, EEHZC1H220P
15	1	C16	CAP., 0.1 μ F, X7R, 25V, 10%, 0402, AEC-Q200	MURATA, GCM155R71E104KE02D
16	2	FB1, FB2	IND., 1k Ω @100MHZ, FERRITE BEAD, 25%, 1.5A, 150mOHMS, 0805, AEC-Q200	TDK, MPZ2012S102ATD25
OPTIONAL ELECTRICAL COMPONENTS				
17	2	C6, C15	CAP., OPTION, 0805	
18	2	C8, C12	CAP., OPTION, 0402	
19	1	D1	DIODE, OPTION, SOD-323F	
20	5	R2, R5, R6, R7, R8	RES., OPTION, 0402	
21	1	R3	RES., OPTION, 0805	
HARDWARE-FOR EVALUATION BOARD ONLY				
22	4	E1, E2, E3, E4	TEST POINT, TURRET, 0.094" MTG. HOLE, PCB 0.062" THK	MILL-MAX, 2501-2-00-80-00-00-07-0
23	5	E5, E6, E8, E9, E10	TEST POINT, TURRET, 0.064" MTG. HOLE, PCB 0.062" THK	MILL-MAX, 2308-2-00-80-00-00-07-0
24	2	JP1, JP2	CONN., HDR, MALE, 2x3, 2mm, VERT, ST, THT	WURTH ELEKTRONIK, 62000621121
25	2	XJP1, XJP2	CONN., SHUNT, FEMALE, 2-POS, 2mm	WURTH ELEKTRONIK, 60800213421

Schematic Diagram

