



EVAL5986 EVAL5986A

2.5 A step-down switching regulator demonstration board based on the L5986, L5986A

Features

- 2.5 A DC output current
- 2.9 V to 18 V input voltage
- Output voltage adjustable from 0.6 V to 16 V
- 250 kHz switching frequency, programmable up to 1 MHz
- Internal soft-start and inhibit
- Low dropout operation: 100% duty cycle
- Zero-load current operation
- Overcurrent and thermal protection
- VFQFPN8 3 mm x 3 mm package or HSOP8 for the L5986A

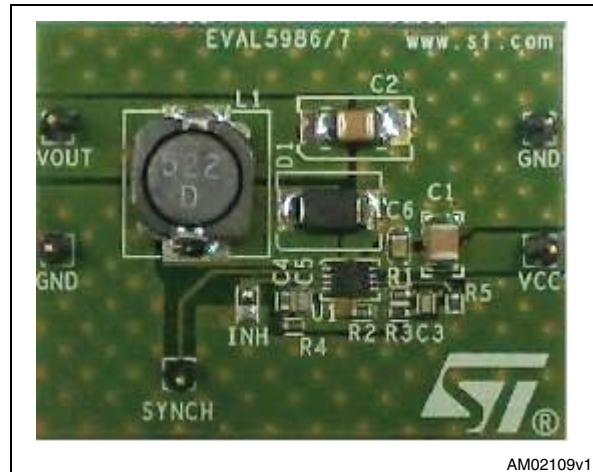

Description

The EVAL5986/A demonstration board provides the design engineer with a fully functional step-down switching regulator with an output current of up to 2.5 A. The board integrates STMicroelectronics' L5986/A step-down switching regulator, together with all the external components required for a typical application.

The rated voltage of the input capacitor and the Schottky diode rectifier repetitive peak reverse voltage are both 25 V, making the board capable of covering the entire 2.9 V - 18 V input voltage range of the L5986/A device.

The board features an external resistor divider (R1 and R2) designed for an output voltage of 1.8 V.

The output voltage can be set to a level from 0.6 V up to the input voltage.

The compensation network on the demonstration board allows the use of MLCC as output filter to keep the loop stable. The inductor saturation current and forward current of the Schottky diode are within the current limit values.

The switching frequency on the demonstration board is set to 500 kHz by means of the R5 resistor connected to pin Fsw.

1 EVAL5986/A application circuit and component list

Figure 1. Application circuit

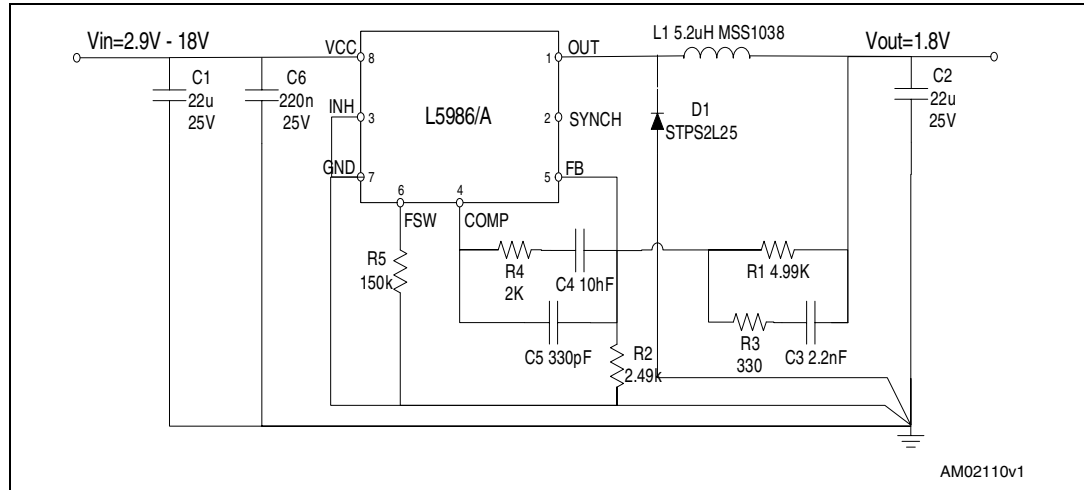

Figure 2. Package

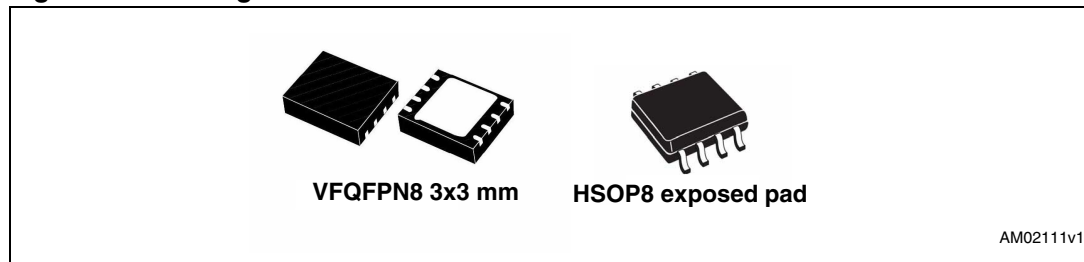

Table 1. Component list

Reference	Part number	Description	Manufacturer
C1	GRM32ER61E226KE15	22 µF, 25 V	Murata
C2	GRM32ER61E226KE15	22 µF, 25 V	Murata
C3		2.2 nF, 50 V	
C4		10 nF, 50 V	
C5		330 pF, 50 V	
C6		220 nF, 25 V	
R1		4.99 kΩ, 1%, 0.1 W 0603	
R2		2.49 kΩ, 1%, 0.1 W 0603	
R3		330 Ω, 1%, 0.1 W 0603	
R4		2 kΩ, 1%, 0.1 W 0603	
R5		100 kΩ, 1%, 0.1 W 0603	
L1	MSS1038-522NL	5.2 µH, 30%, 5.28 A	Coilcraft
D1	STPS2L25V	2 A, 25 V	STMicroelectronics

2 PCB layout

Figure 3. PCB layout (component side)

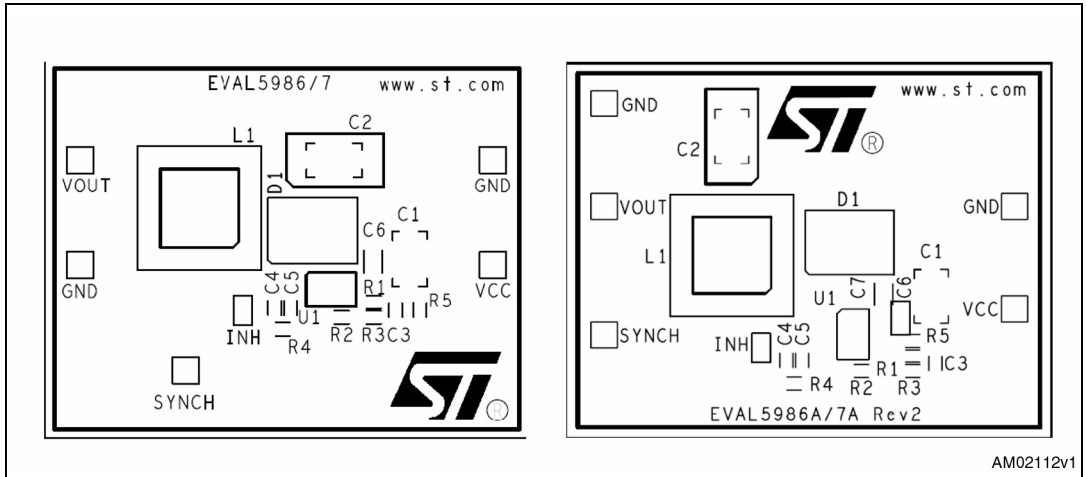

Figure 4. PCB layout (bottom side)

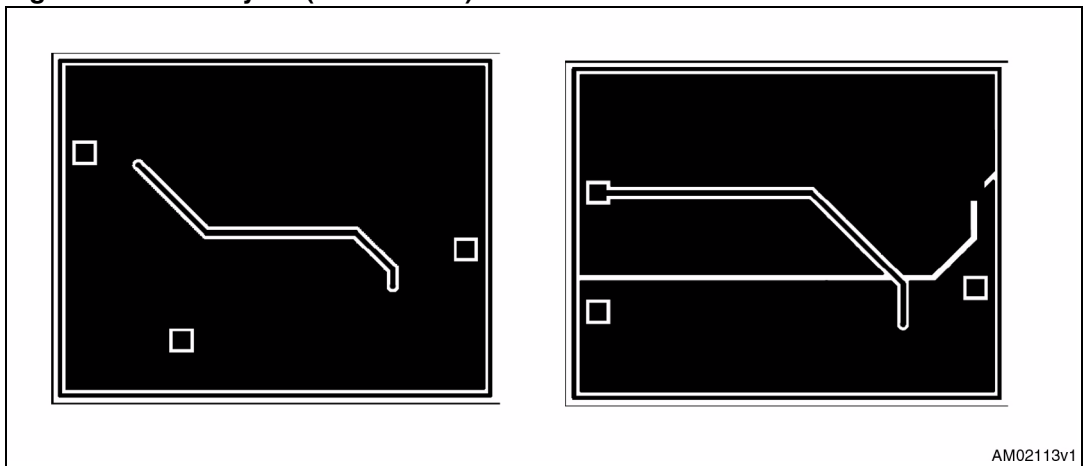
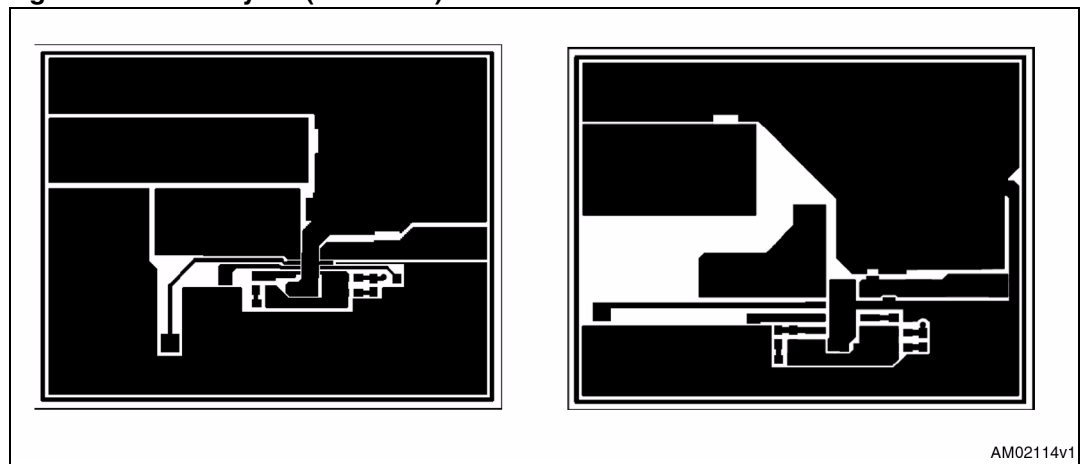

Figure 5. PCB layout (front side)



3 Package mechanical data

In order to meet environmental requirements, ST offers these devices in different grades of ECOPACK[®] packages, depending on their level of environmental compliance. ECOPACK[®] specifications, grade definitions and product status are available at: www.st.com. ECOPACK[®] is an ST trademark.

4 Revision history

Table 2. Document revision history

Date	Revision	Changes
29-Oct-2009	1	Initial release