

Stepper motor driver mounting the L6208Q

Data brief



Features

- Voltage range from 8 to 52 V
- Phase current up to 2.5 A_{r.m.s.}
- Adjustable PWM current control OFF-time
- Logic inputs 5 V / 3.3 V compliant
- Small application footprint with high thermal performance
- Suitable for use in combination with PractiSPIN™ 2 software

Description

The EVAL6208Q device is a stepper motor driver board allowing the user to test the L6208Q functions.

The board can be driven using the STEVAL-PCC009V2 demonstration board and the PractiSPIN 2 evaluation software.

Contents

1	Board description	3
2	Schematic	5
3	Bill of material	6
4	Layout	7
5	Revision history	10

1 Board description

Table 1. Electrical specifications

Parameter	Value
Supply voltage (VS)	8 to 52 V
Maximum output current (each phase)	2.5 A _{r.m.s.}
Low level logic input voltage	0 V
High level logic input voltage	5 V / 3.3 V ⁽¹⁾
Maximum VREF _A /VREF _B input voltage (J2 connector)	3.3 V ⁽²⁾
Switching frequency	Up to 100 kHz
Operating temperature	- 25 to +125 °C
L6208Q thermal resistance junction-to-ambient	17 °C/W

1. Logic inputs are 3.3 V and 5 V compliant.
2. Equivalent to about 3.1 A peak current.

Figure 1. Trimmer and connector locations

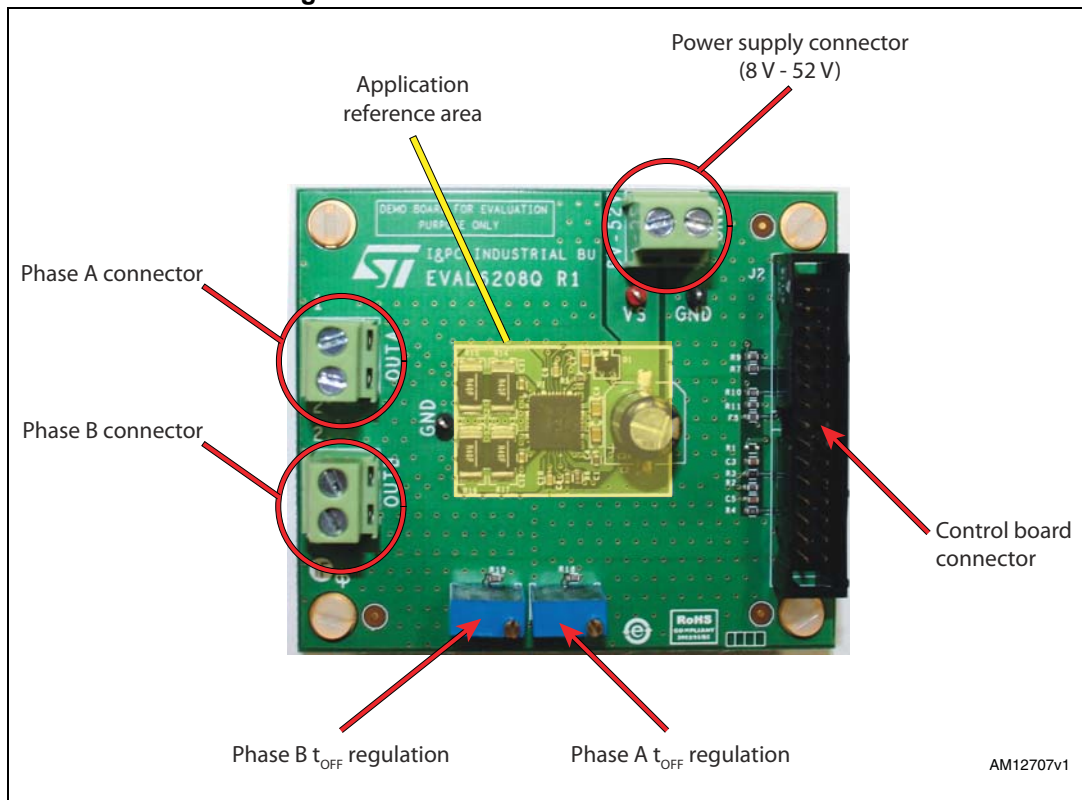
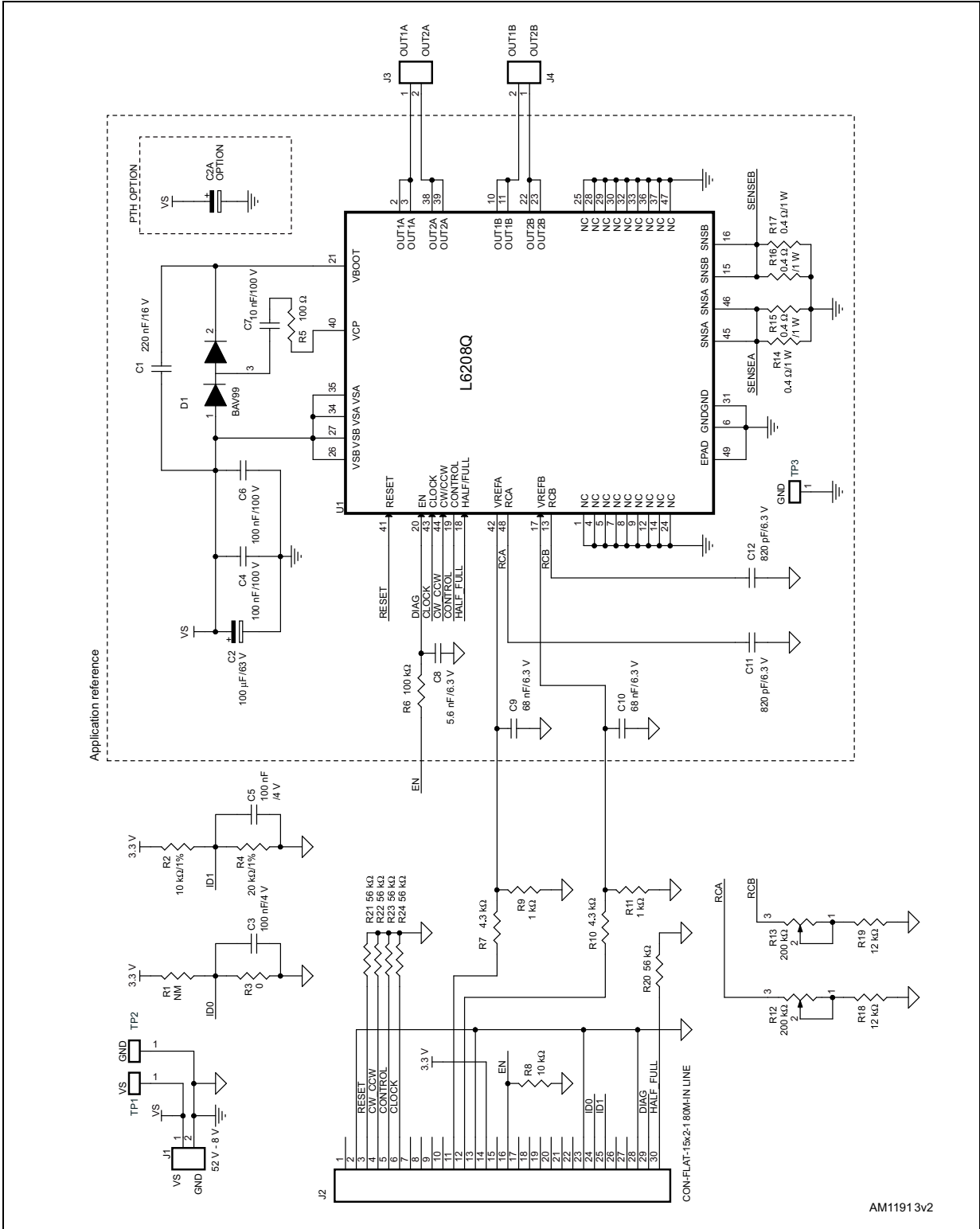

Table 2. Control board connector pinout (J2)

Pin	Type	Function
2	Ground	Ground
3	Logic input	Active low reset of L6208Q
4	Logic input	Direction input (CW/CCW input of L6208Q)
5	Logic input	Decay mode selection input (CONTROL input of L6208Q)
6	Logic input	Step clock input (CLOCK input of L6208Q)
11	Analog input	Reference voltage for phase A current control
12	Analog input	Reference voltage for phase B current control
13	Ground	Ground
14	Supply voltage	3.3 V supply voltage
16	Logic input	Device enable input (EN input of L6208Q)
23	Ground	Ground
24	Analog output	Board identification system ID0
25	Analog output	Board identification system ID1
28	Ground	Ground
29	Logic output	Fault output (EN output of L6208Q)
30	Logic input	Step mode selection input (HALF/FULL input of L6208Q)
Others	Unconnected	

2 Schematic

Figure 2. Schematic



3 Bill of material

Table 3. Bill of material

Index	Quantity	Reference	Value	Package
1	1	C1	220 nF /16 V	CAPC-0603
2	1	C2	100 μ F / 63 V	CAPE-R10H10
3	1	C2A	100 μ F / 63 V (OPTION)	CAPE-R8H12-P35
4	2	C3, C5	100 nF / 4 V	CAPC-0603
5	2	C4, C6	100 nF / 100 V	CAPC-0805
6	1	C7	10 nF / 100 V	CAPC-0805
7	1	C8	5.6 nF / 6.3 V	CAPC-0603
8	2	C9, C10	68 nF / 6.3 V	CAPC-0603
9	2	C11, C12	820 pF / 6.3 V	CAPC-0603
10	1	D1	BAV99	SOT23
11	3	J1, J3, J4	Screw connector 2 poles	MORSV-508-2P
12	1	J2	Pol. IDC male header vertical 30 poles	CON-FLAT-15X2-180M
13	1	R1	NM	RESC-0603
14	1	R2	10 k Ω / 1%	RESC-0603
15	1	R3	0	RESC-0603
16	1	R4	20 k Ω /1%	RESC-0603
17	1	R5	100 Ω	RESC-0603
18	1	R6	100 k Ω	RESC-0603
19	2	R7, R10	4.3 Ω	RESC-0603
20	1	R8	10 k Ω	RESC-0603
21	2	R9, R11	1 k Ω	RESC-0603
22	2	R12, R13	200 k Ω	TRIMM-100x50x110-64W
23	4	R14, R15, R16, R17	0.4 Ω / 1 W	RESC-2512
24	2	R18, R19	12 k Ω	RESC-0603
25	5	R20, R21, R22, R23, R24	56 k Ω	RESC-0603
26	1	TP1	TPTH-RING-1MM RED	TH
27	2	TP2, TP3	TPTH-RING-1MM BLACK	TH
28	1	U1	L6208Q	QFN7x7_48

4 Layout

Figure 3. Layout (silk screen)

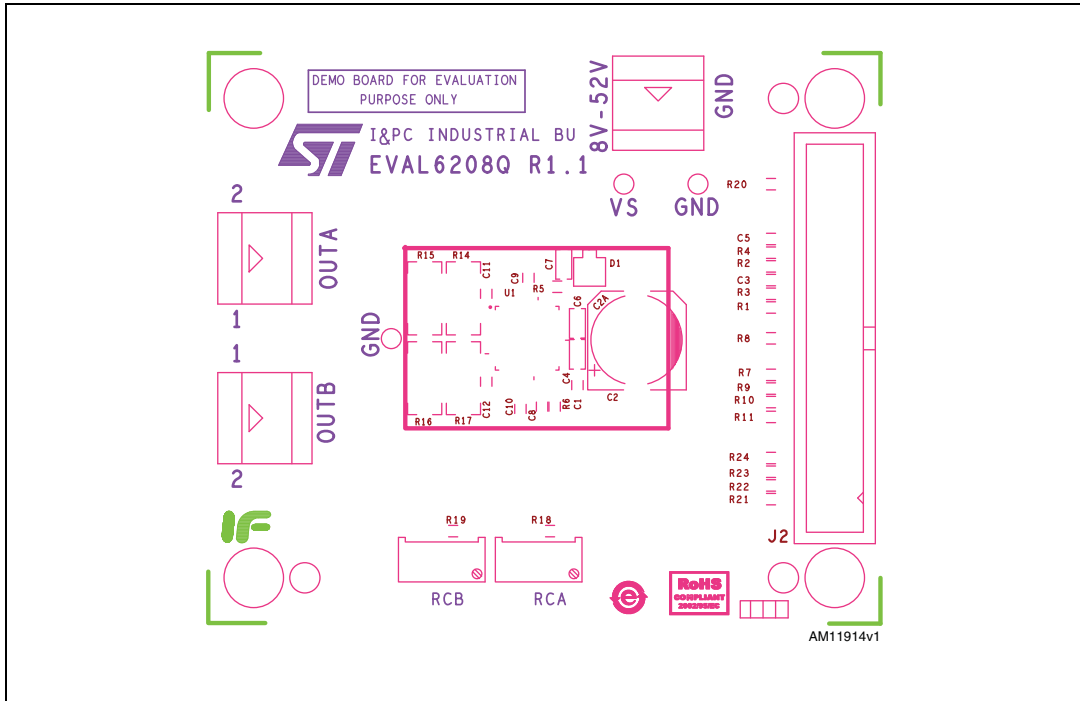

Figure 4. Layout (top layer)

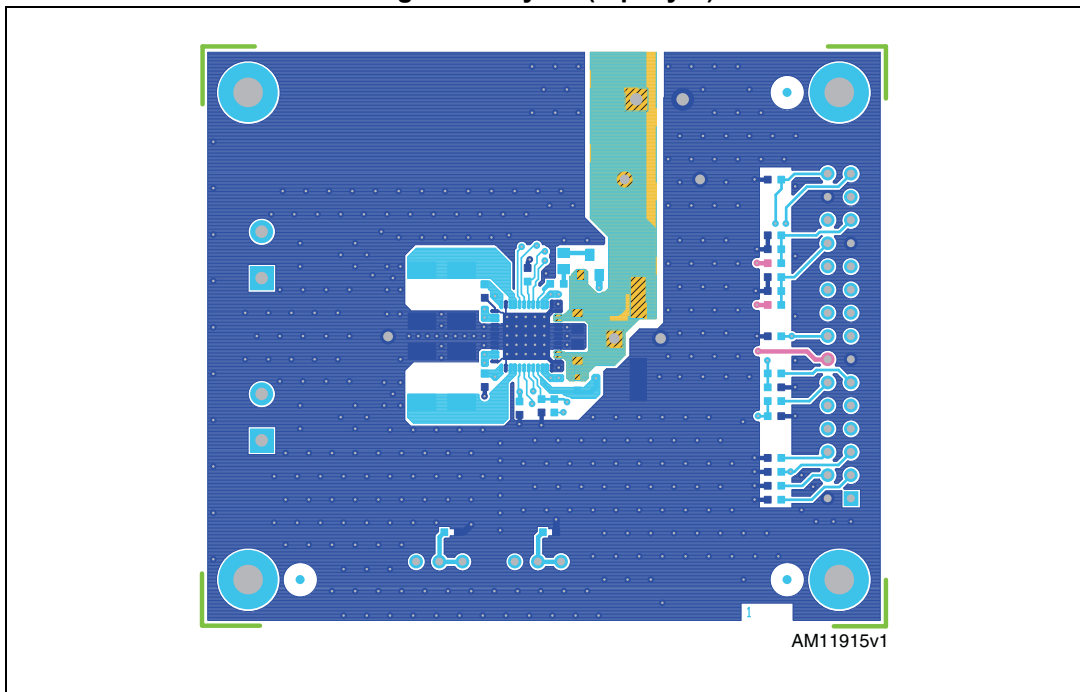

Figure 5. Layout (inner layer 2)

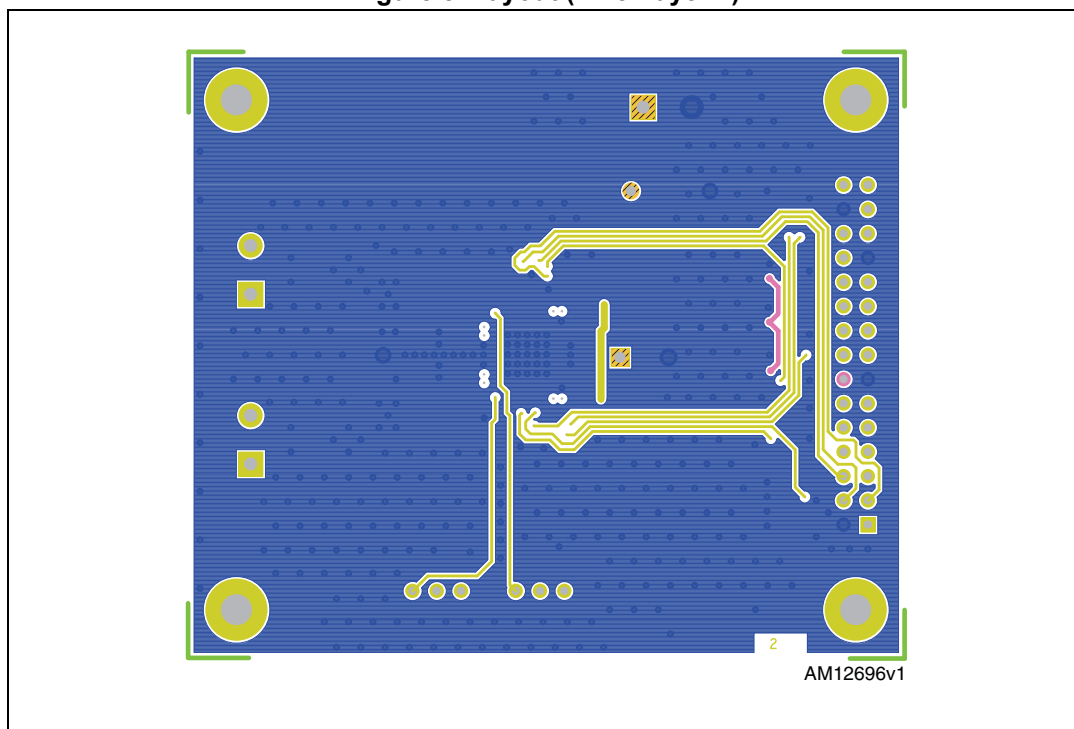

Figure 6. Layout (inner layer 3)

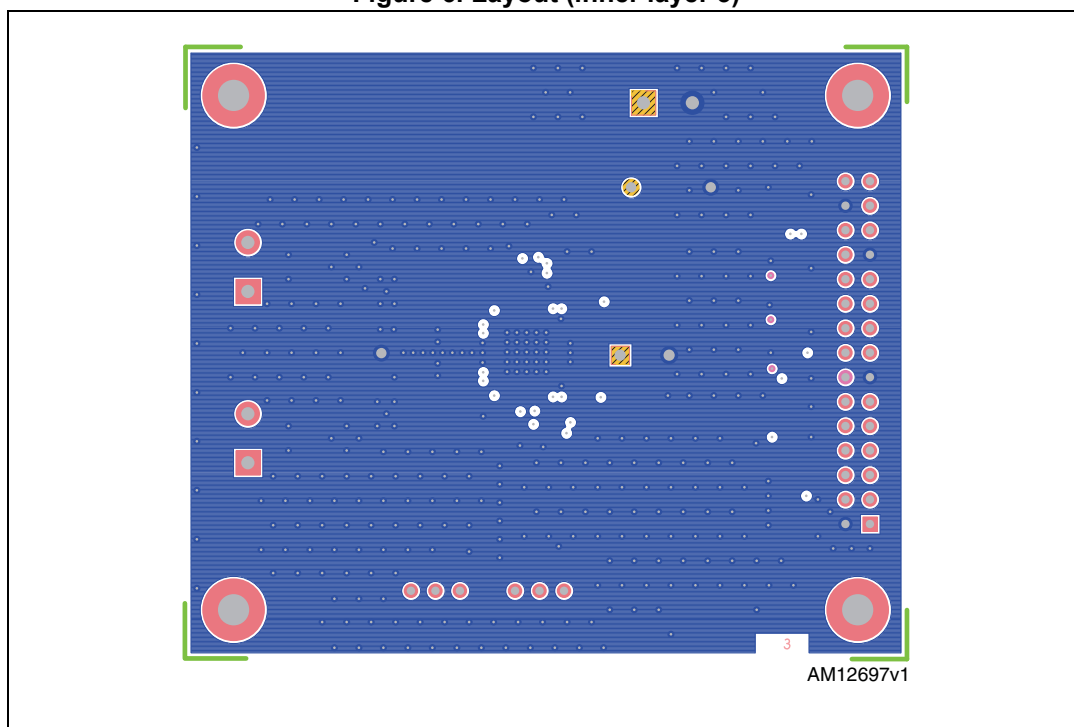
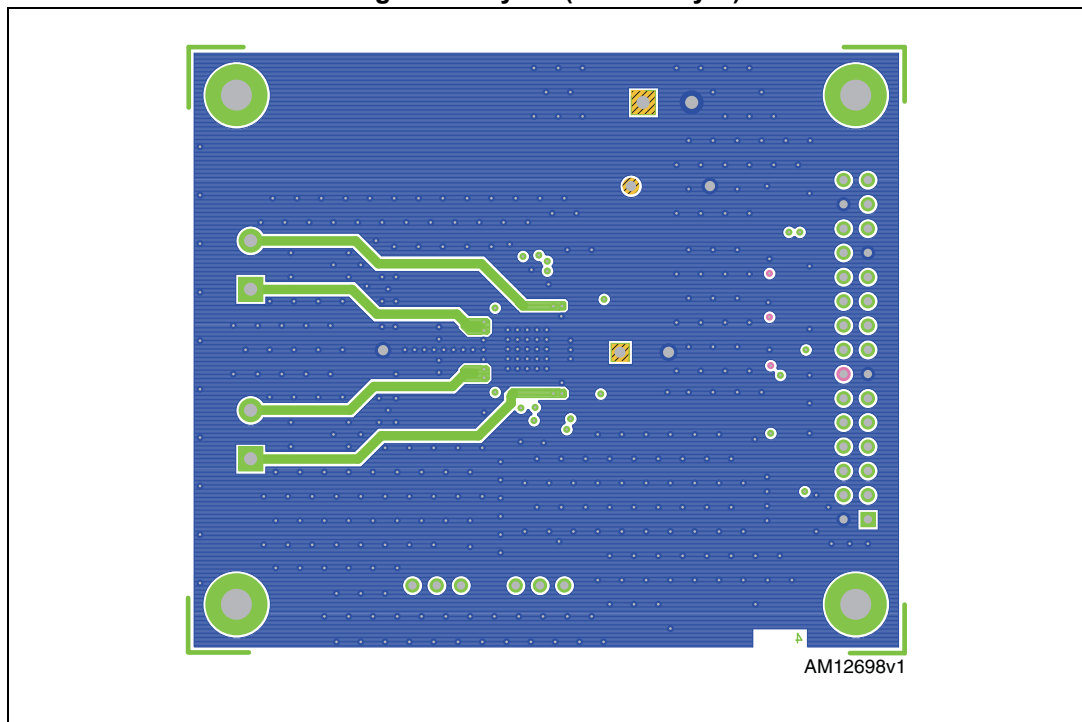

Figure 7. Layout (bottom layer)



5 Revision history

Table 4. Document revision history

Date	Revision	Changes
03-Apr-2012	1	Initial release.
07-Jun-2013	2	<p>Updated Description on page 1 (replaced “communication board” by “demonstration board”).</p> <p>Added Contents on page 2.</p> <p>Added headings to Section 2: Schematic to Section 4: Layout.</p> <p>Updated Table 1 (removed superfluous “EVAL6208Q” from title, added value and unit for “thermal resistance junction-to-ambient”).</p> <p>Updated Figure 2 (removed “EVAL6208Q” from title, completed units, minor modifications).</p> <p>Updated Table 3 (removed “EVAL6208Q” from title, corrected unit in row 23).</p> <p>Updated Figure 3 to Figure 7 (removed “EVAL6208Q” from titles).</p> <p>Minor corrections throughout document.</p>