

## Fully integrated stepper motor driver mounting the L6470

Data brief



### Description

The EVAL6470H demonstration board is a fully integrated microstepping motor driver. In combination with the STEVAL-PCC009V2 communication board and the SPIN evaluation software, the board allows the user to investigate all the features of the L6470 device. In particular, the board can be used to check the voltage mode driving and to regulate the L6470 parameters in order to fit the application requirements.

The EVAL6470H supports the daisy chain configuration making it suitable for the evaluation of the L6470 in multi motor applications.

### Features

- Voltage range from 8 V to 45 V
- Phase current up to 3 A<sub>rms</sub>
- SPI with daisy chain feature
- Socket for external resonator or crystal
- SW input
- FLAG and BUSY LED indicators
- Adjustable supply voltage compensation
- Suitable to be used in combination with STEVAL-PCC009V2

# Board description

**Table 1. EVAL6470H specifications**

Parameter	Value
Supply voltage (VS)	8 to 45 V
Maximum output current (each phase)	3 A <sub>r.m.s.</sub>
Logic supply voltage (VREG)	Externally supplied: 3.3 V, internally supplied: 3 V (typ.)
Logic interface voltage (VDD)	Externally supplied: 3.3 V or 5 V, internally supplied: VREG
Low level logic inputs voltage	0 V
High level logic input voltage	VDD <sup>(1)</sup>
Operating temperature	-25 to +125 °C
L6470H thermal resistance junction to ambient	21 °C/W (typ.)

1. All logic inputs are 5 V tolerant.

**Figure 1. Jumpers and connectors location**

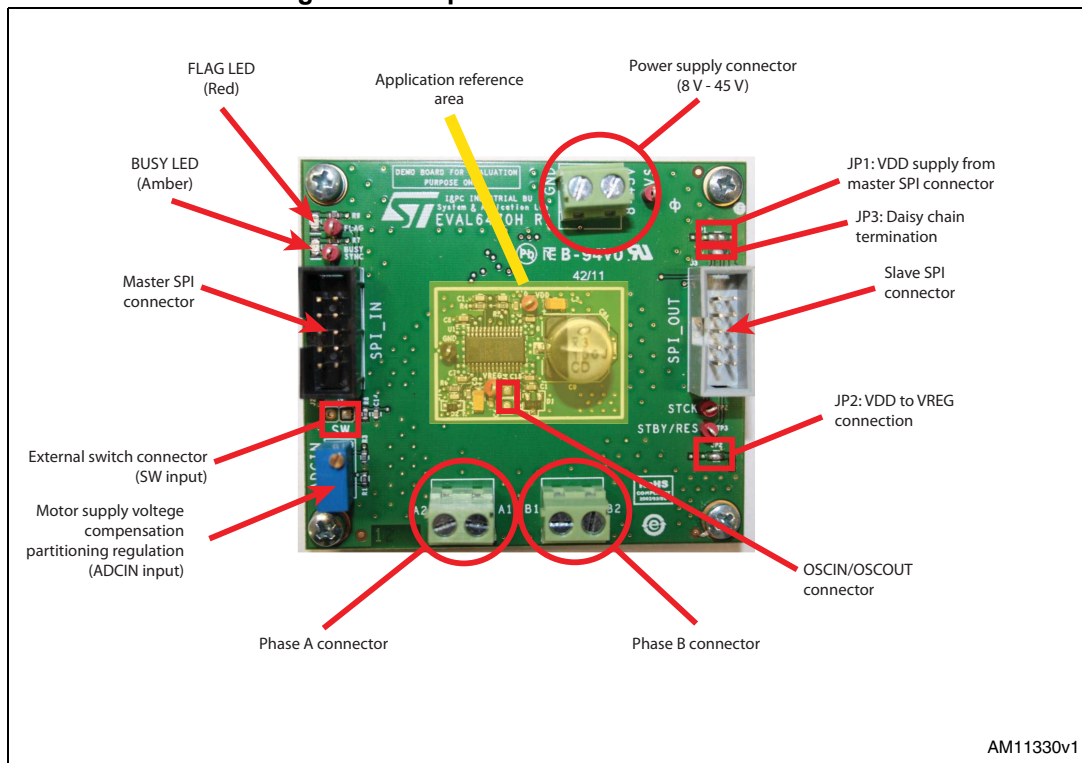

AM11330v1

**Table 2. Jumpers and connectors description**

Name	Type	Function
J1	Power supply	Motor supply voltage
J5	Power output	Bridge A outputs
J6	Power output	Bridge B outputs
J2	SPI connector	Master SPI
J3	SPI connector	Slave SPI
J4	NM connector	OSCIN and OSCOUT pins
J7	NM connector	External switch input
TP1 (VS)	Test point	Motor supply voltage test point
TP4 (VDD)	Test point	Logic interface supply voltage test point
TP5 (VREG)	Test point	Logic supply voltage/L6470 internal regulator test point
TP6 (GND)	Test point	Ground test point
TP2 (STCK)	Test point	Step clock input test point
TP3 (STBY/RES)	Test point	Standby/reset input test point
TP7 (FLAG)	Test point	FLAG output test point
TP8 (BUSY/SYNC)	Test point	BUSY/SYNC output test point

**Table 3. Master SPI connector pinout (J10)**

Pin number	Type	Description
1	Open drain output	L6470 BUSY/SYNC output
2	Open drain output	L6470 FLAG output
3	Ground	Ground
4	Supply	EXT_VDD (can be used as external logic power supply)
5	Digital output	SPI "Master In Slave Out" signal (connected to L6470 SDO output through daisy chain termination jumper JP2)
6	Digital input	SPI serial clock signal (connected to L6470 CK input)
7	Digital input	SPI "Master Out Slave In" signal (connected to L6470 SDI input)
8	Digital input	SPI slave select signal (connected to L6470 CS input)
9	Digital input	L6470 step-clock input
10	Digital input	L6470 STBY/RST input

Table 4. SPI connector pinout (J11)

Pin number	Type	Description
1	Open drain output	L6470 BUSY/SYNC output
2	Open drain output	L6470 FLAG output
3	Ground	Ground
4	Supply	EXT_VDD (can be used as external logic power supply)
5	Digital output	SPI "Master In Slave Out" signal (connected to pin 5 of J10)
6	Digital input	SPI serial clock signal (connected to L6470 CK input)
7	Digital input	SPI "Master Out Slave In" signal (connected to L6470 SDO output)
8	Digital input	SPI slave select signal (connected to L6470 CS input)
9	Digital input	L6470 step-clock input
10	Digital input	L6470 STBY/RST input

Figure 2. EVAL6470H - schematic

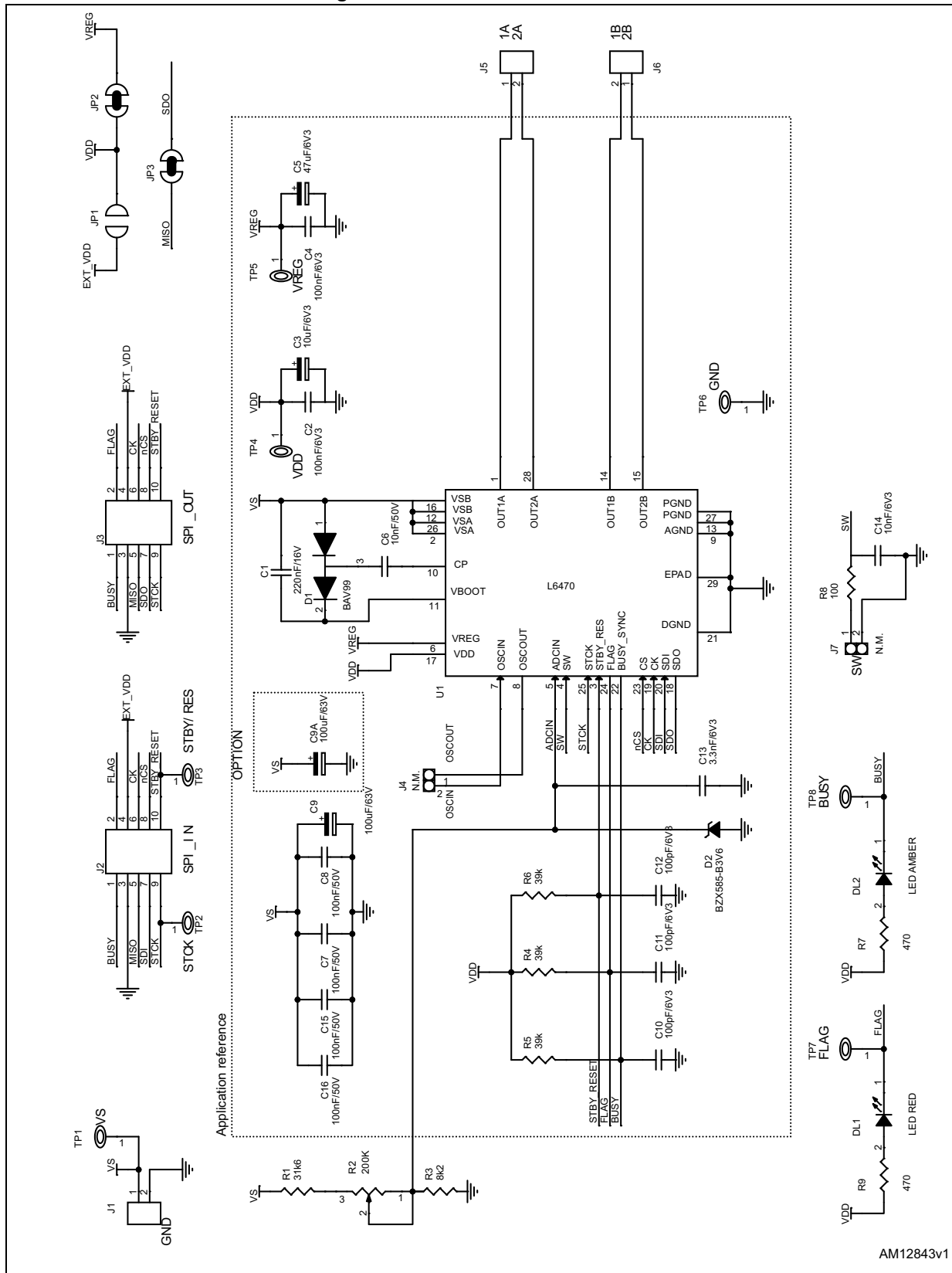

Table 5. EVAL6470H - bill of material

Item	Quantity	Reference	Value	Package
1	1	C1	220 nF/16 V	CAPC-0603
2	2	C2, C4	100 nF/6.3 V	CAPC-0603
3	1	C3	10 $\mu$ F/6.3 V	CAPC-3216
4	1	C5	47 $\mu$ F/6.3 V	CAPC-3216
5	1	C6	10 nF/50 V	CAPC-0603
6	4	C7, C8, C15, C16	100 nF/50 V	CAPC-0603
7	1	C9A	100 $\mu$ F/63 V	CAPE-R8H12-P35
8	1	C9	100 $\mu$ F/63 V	CAPE-R10HXX
9	3	C10, C11, C12	100 pF/6.3 V	CAPC-0603
10	1	C13	3.3 nF/6.3 V	CAPC-0603
11	1	C14	10 nF/6.3 V	CAPC-0603
12	1	DL1	LED diode (red)	LEDC-0805
13	1	DL2	LED diode (amber)	LEDC-0805
14	1	D1	BAV99	SOT23
15	1	D2	BZX585-B3V6(1)	SOD523
16	1	JP1	Jumper - OPEN	JP2SO
17	2	JP2, JP3	Jumper - CLOSED	JP2SO
18	3	J1, J5, J6	Screw connector 2 poles	MORSV-508-2P
19	2	J2, J3	Pol. IDC male header vertical 10 poles	CON-FLAT-5 x 2-180 M
20	2	J4, J7	N.M.	STRIP254P-M-2
21	1	R1	31.6 k $\Omega$	RESC-0603
22	1	R2	200 k $\Omega$	TRIMM-100 x5 0 x110 - 64 W
23	1	R3	8.2 k $\Omega$	RESC-0603
24	3	R4, R5, R6	39 k $\Omega$	RESC-0603
25	2	R7, R9	470 $\Omega$	RESC-0603
26	1	R8	100 $\Omega$	RESC-0603
27	8	TP1, TP2, TP3, TP4, TP5, TP6, TP7, TP8	Test point	TH
28	1	U1	L6470H	HTSSOP28

Figure 3. EVAL6470H - layout (top layer)

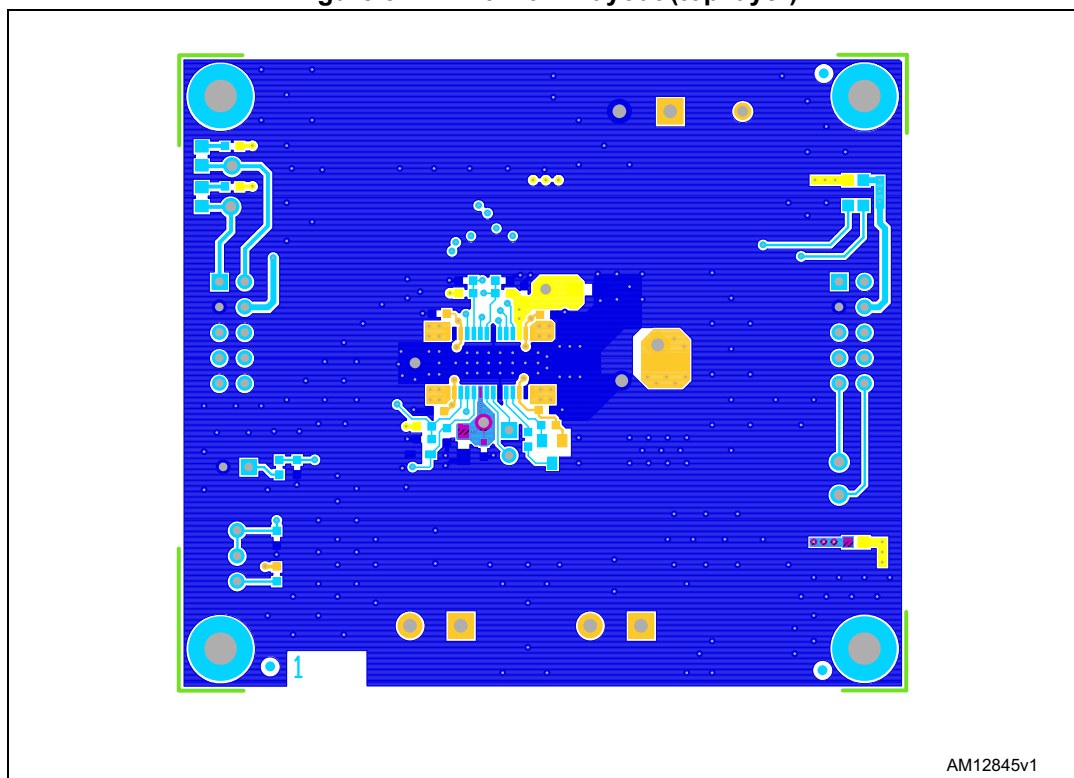

Figure 4. EVAL6470H - layout (inner layer 2)

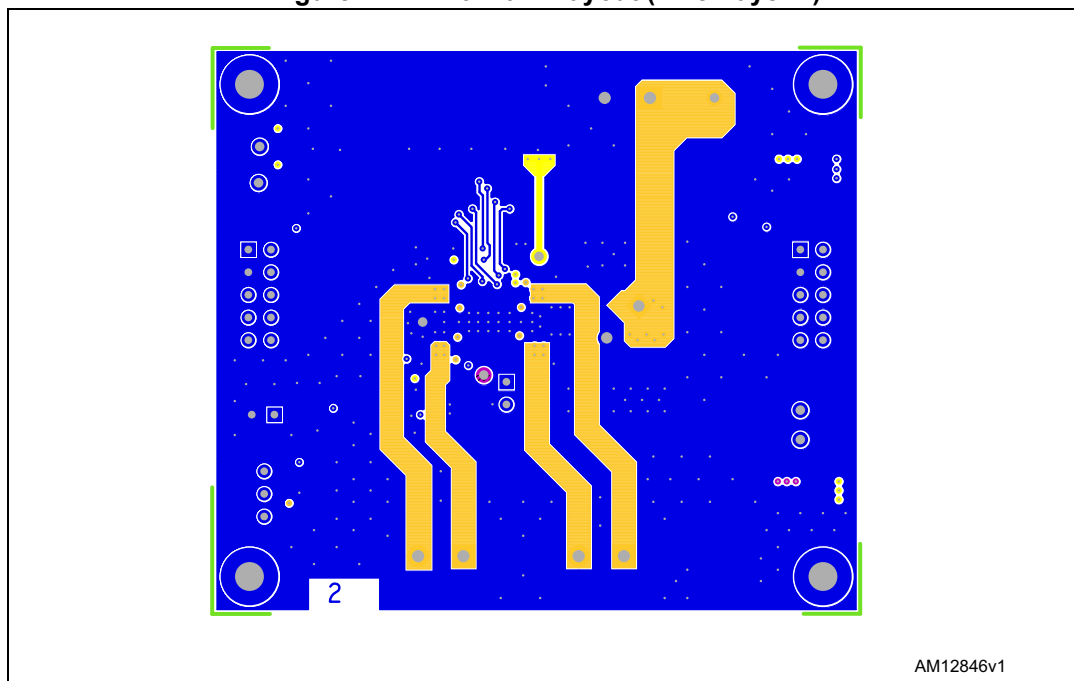

Figure 5. EVAL6470H - layout (inner layer 3)

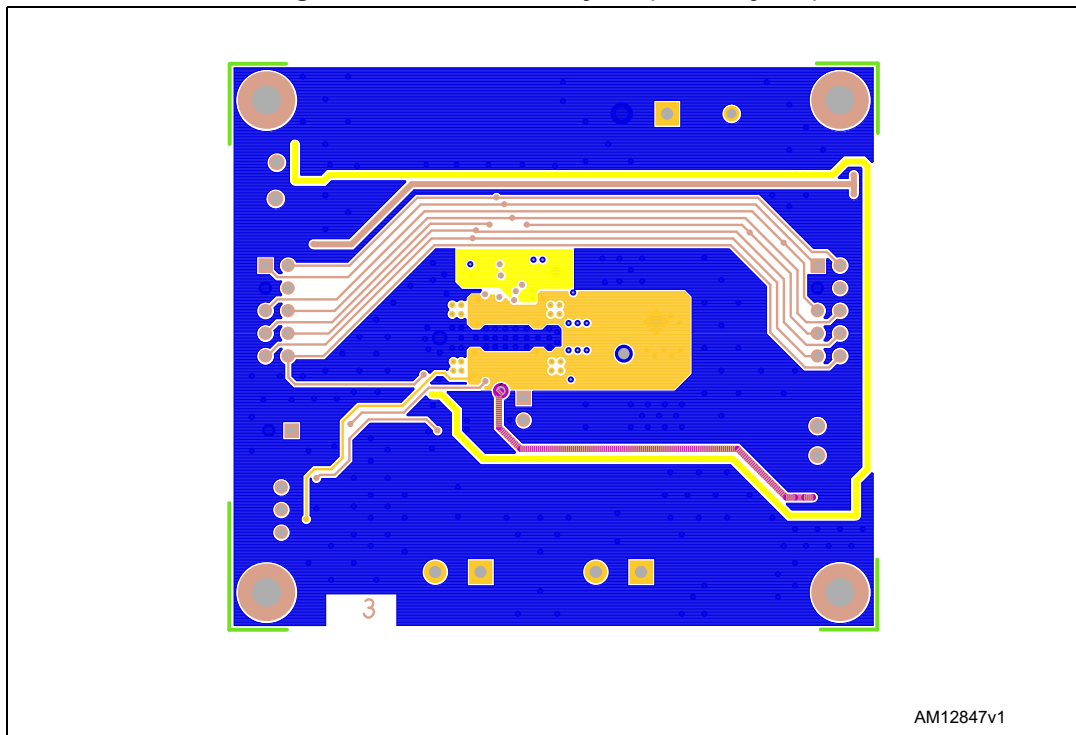
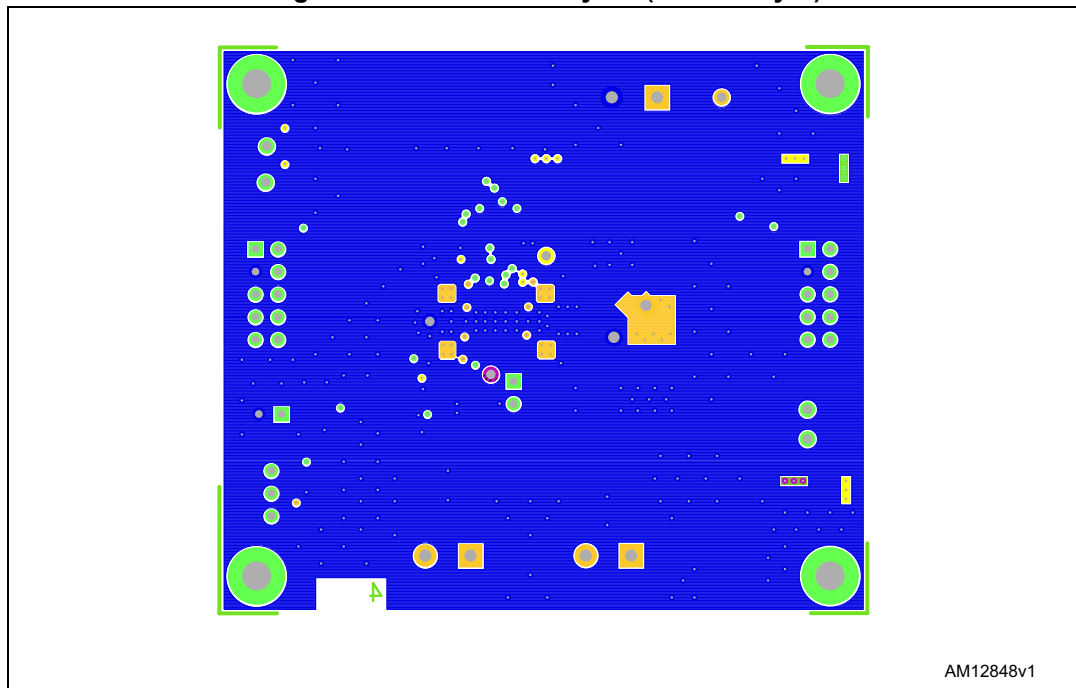

Figure 6. EVAL6470H - layout (bottom layer)





### Thermal data

Figure 7. Thermal impedance graph

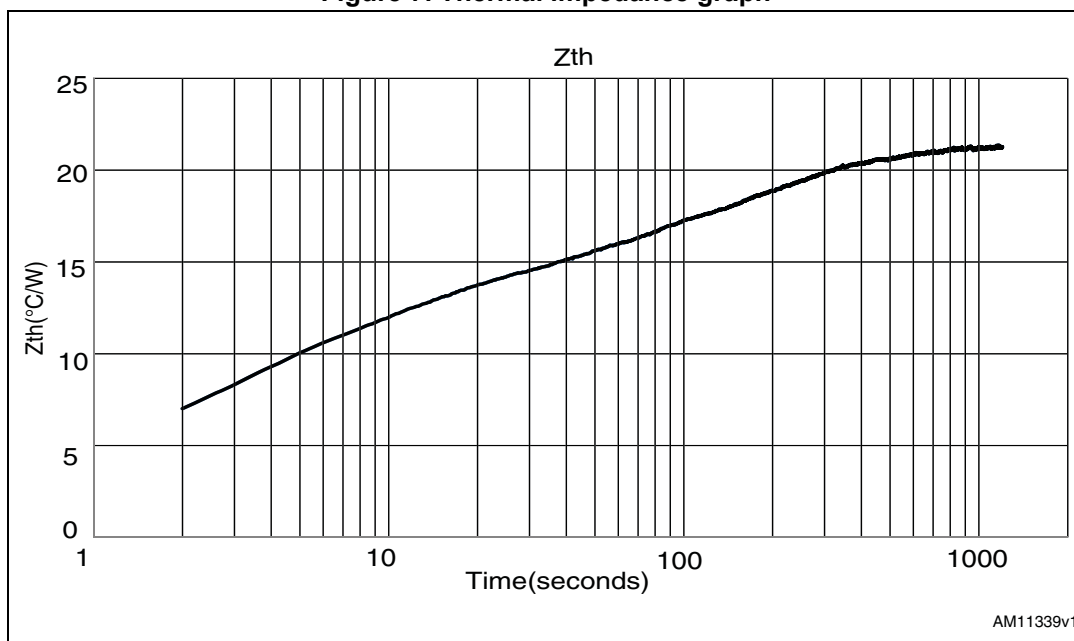

## Revision history

**Table 6. Document revision history**

Date	Revision	Changes
25-Jan-2012	1	Initial release.
23-Apr-2012	2	Updated information: <a href="#">Table 2</a> for connector TP3 (STBY/RES). <a href="#">Table 3</a> , and <a href="#">Table 4</a> description changed for pin 1 and pin 10 <a href="#">Table 5</a> for item 15. Updated: <a href="#">Figure 2</a> , <a href="#">Figure 3</a> , <a href="#">Figure 4</a> , <a href="#">Figure 5</a> , <a href="#">Figure 6</a> , and <a href="#">Figure 7</a> .
18-Mar-2015	3	Replaced “dSPIN” by “SPIN” in <a href="#">Section : Description on page 1</a> . Removed Figure 3. “EVAL6470H - layout (silk screen)” from page 7. Minor modifications throughout document.