

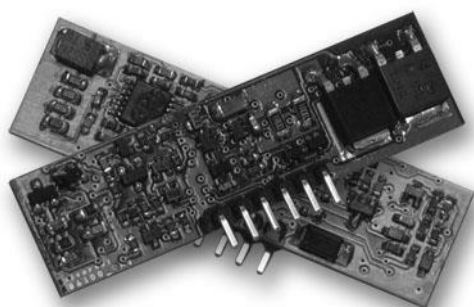

Ag6100

POE+ Power-Sourcing-Equipment Module



1. Features

- Compliant with IEEE802.3at Type 1 (af) & Type 2
- Small SIL package size - 53mm (L) x 14mm (H)
- Low cost
- Output power up to 39W
- Minimal (low cost) external components required
- Over-current and short circuit protection
- Industrial Temperature Range
- Silvertel "design-in" assistance

2. Description

The Ag6100 is a single output Power Sourcing Equipment (PSE) module designed for use in IEEE802.3at Type 1 (af) and Type 2 Power over Ethernet (PoE) applications.

The Ag6100 is capable of delivering up to 39W and is aimed at applications requiring PSE functionality such as CCTV DVR, home networking and industrial Ethernet.

Ag6100 is a self-contained module, requiring just a few external components to provide a great deal of control and feedback over each Powered Device (PD) that is connected to the PSE.

Table of Contents

1. Features	1
2. Description.....	1
Table of Contents	2
Table of Figures	2
3. Ag6100 Product Selector.....	3
4. Pin Description	4
5. Functional Description	4
5.1 Power Supplies.....	4
5.2 Port Output	5
6. Signature and Classification	6
6.1 Signature Detection	7
6.2 Classification	7
6.3 Maintain Power Signature	8
6.4 Output Current Limits	8
6.5 Output Power.....	8
7. STATUS Output.....	8
8. Protection	11
8.1 Input Protection	11
8.2 Output Short-Circuit Protection.....	11
9. Electrical Characteristics	12
9.1 Absolute Maximum Ratings ¹	12
9.2 Recommended Operating Conditions.....	12
9.3 Electrical Characteristics	12
10. Package	13

Table of Figures

Figure 1: Block Diagram	3
Figure 2: Ag6100 Package Format	3
Figure 3: Power Supply Connections.....	4
Figure 4: Typical Connection Diagram.....	5
Figure 5: Signature, Class and Turn-On Timing - Type 1 PD	6
Figure 6: Signature, Class and Turn-On Timing - Type 2 PD	6
Figure 7: Signature Cycle Time	7
Figure 8: STATUS Output at Port Connect and Disconnect	9
Figure 9: STATUS Output when a Short Circuit is applied to the Output Port	9
Figure 10: STATUS Output when an Over-Current is applied to the Output Port	10
Figure 11: STATUS Output when an Over-Current fault is not removed	10
Figure 12: STATUS Output Configuration.....	11

3. Ag6100 Product Selector

Part Number†	Output Power (W)	Marking
Ag6100-S	39	S

† The Ag6100 fully meets the requirements of the RoHS directive 2002/95/EC on the restriction of hazardous substances in electronic equipment.

Table 1: Ordering Information

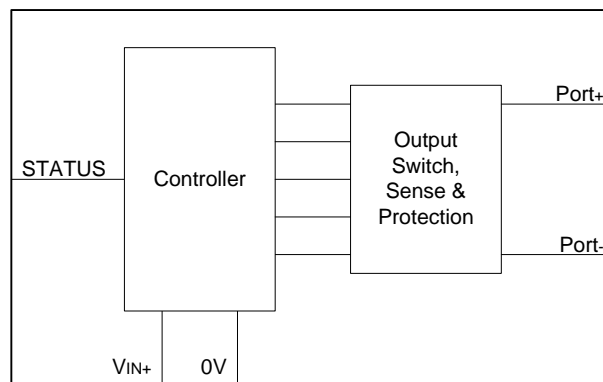

Figure 1: Block Diagram

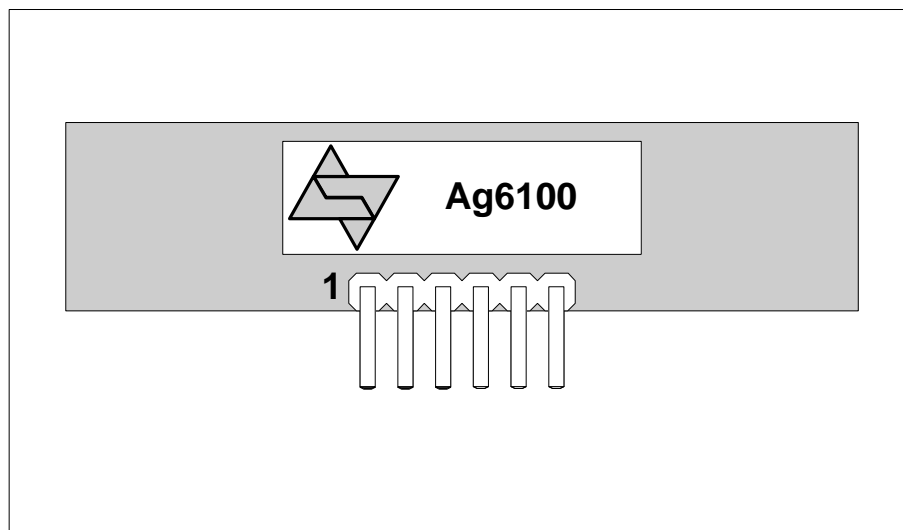

Figure 2: Ag6100 Package Format

4. Pin Description

Pin #	Name	Description
1	V _{IN+}	Main Power Supply. This pin connects to an isolated 45V to 57V supply; relative to the 0V.
2	0V	0V. This pin is the return path for the isolated V _{IN+} power supply.
3	STATUS	Status Output. This output shows the status of the Ag6100.
4	Port+	Port Output. This output pin monitors the line and supplies power to valid powered device.
5	Port-	Port Output Return. This pin is the return path for Port+.
6	NC	No Connection.

5. Functional Description

5.1 Power Supplies

The Ag6100 only requires one power supply; to conform to the IEEE802.3at specification, this supply must be isolated from mains ground, as shown in Figure 3.

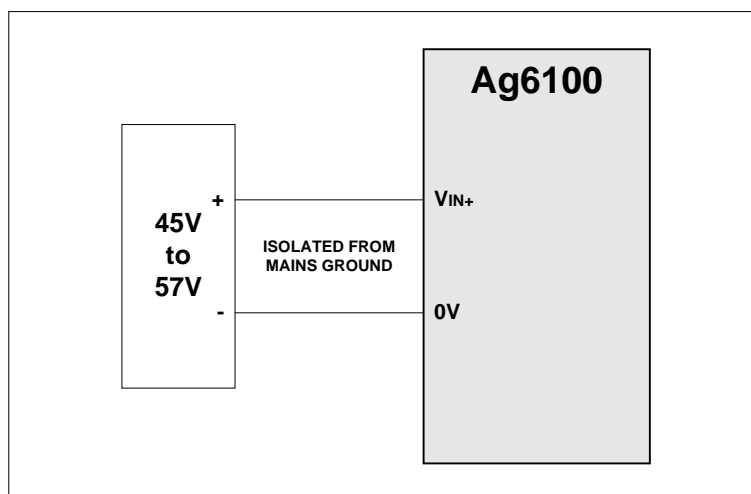

Figure 3: Power Supply Connections

5.2 Port Output

The Port output can be connected directly to the centre-tap of an IEEE802.3at compliant data transformer or to the spare pair connection for 10/100BASE-T applications, as shown in Figure 4. For 1000BASE-T (Gigabit) Ethernet applications all four cable pairs require magnetics, this is explained in more detail in application note “ANX-1000BASE-T-CONNECTIONS”.

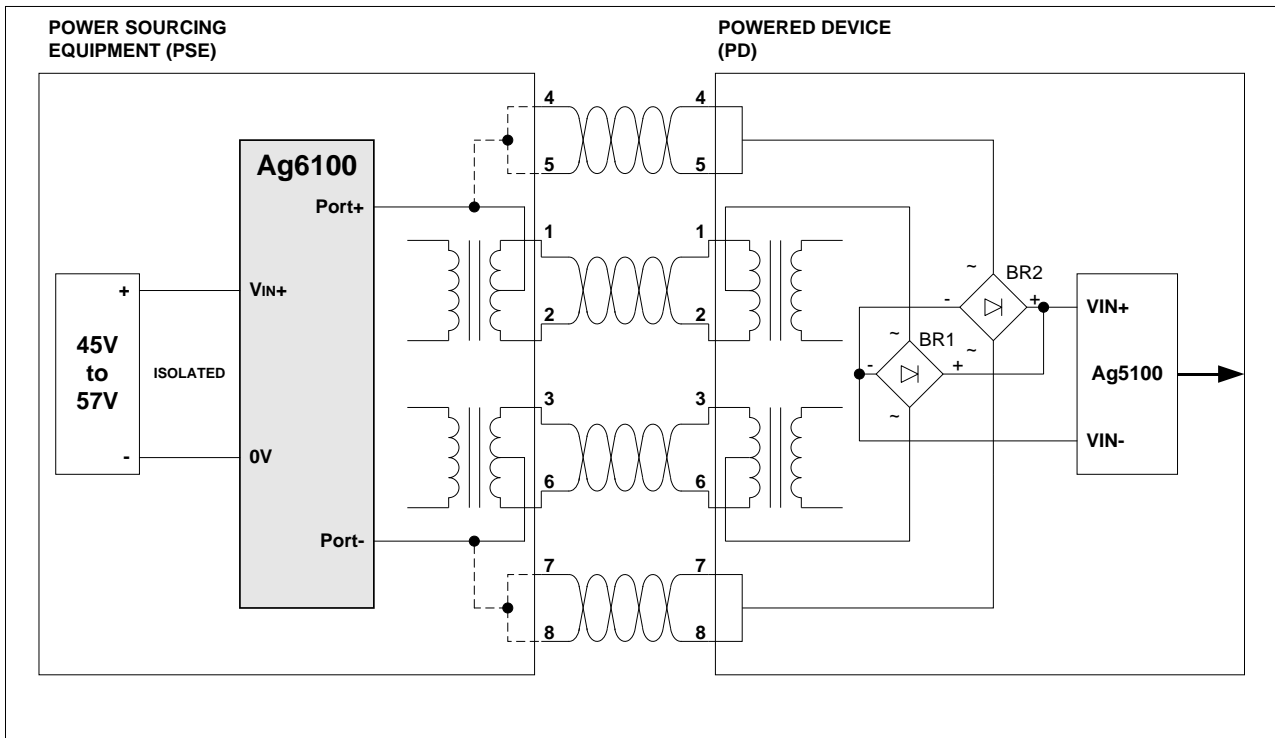

Figure 4: Typical Connection Diagram

6. Signature and Classification

The Ag6100 will automatically perform the Signature and Classification, Figure 5 shows the timing sequence for a Type 1 Powered Device (PD) and Figure 6 shows the timing sequence for a Type 2 PD.

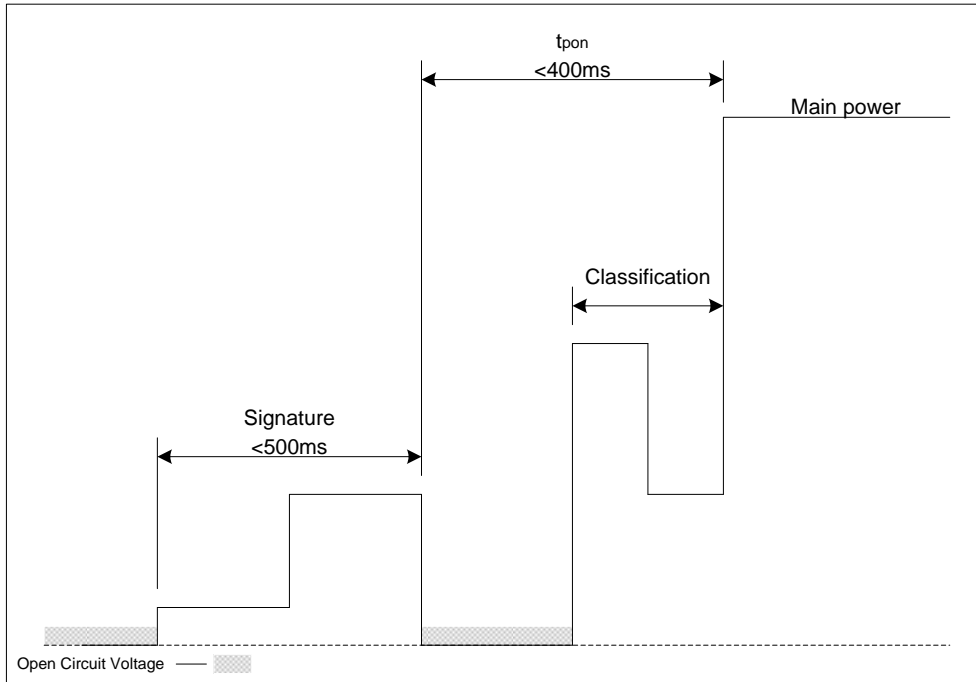

Figure 5: Signature, Class and Turn-On Timing - Type 1 PD

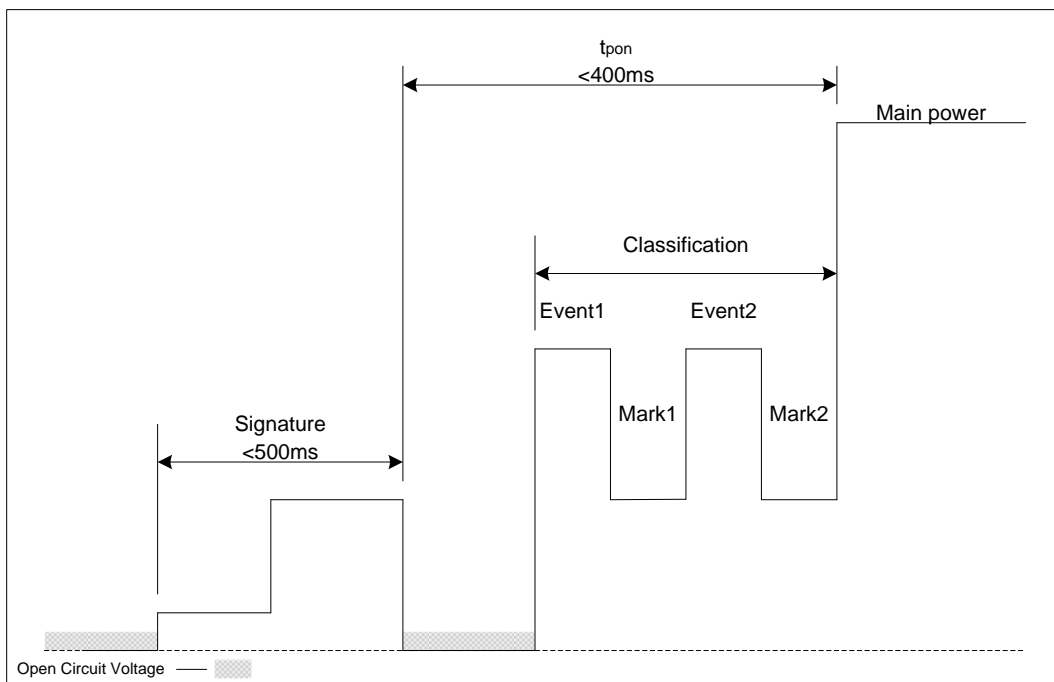

Figure 6: Signature, Class and Turn-On Timing - Type 2 PD

The IEEE802.3at separates the power handling into two basic categories “Type 1” and “Type 2”. In simple terms Type 1 handles power requirements up to 15.4W and is comparable with the IEEE802.3af specification. Type 2 handles the power levels above this, which is commonly referred to as POE+.

6.1 Signature Detection

To ensure that the Ag6100 does not apply power to a non PoE enabled device the Port output first checks for a valid PoE signature. The PD should present a nominal 25kΩ (23.75kΩ to 26.25kΩ) Signature resistance; if the Ag6100 does not see a valid signature then it will disconnect, wait approximately 2 seconds then try again, see Figure 7 below.

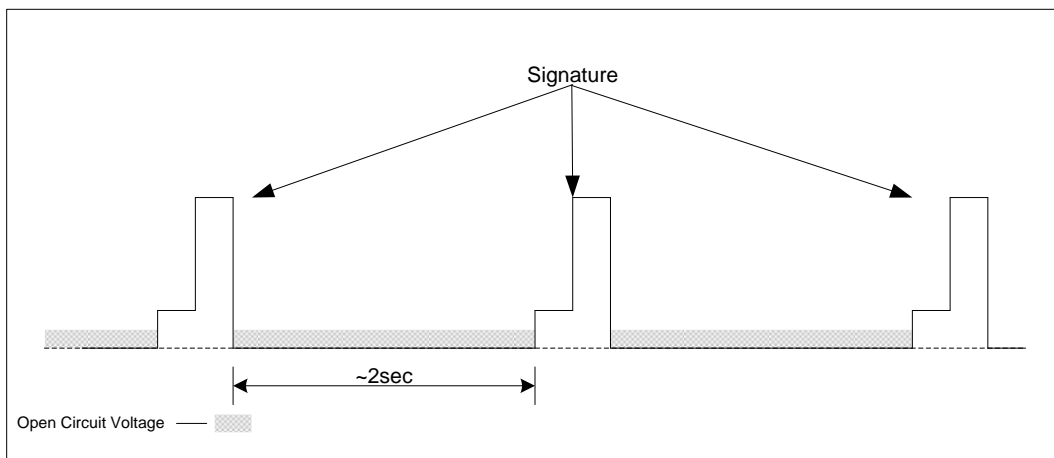

Figure 7: Signature Cycle Time

6.2 Classification

On completion of a valid signature, the Ag6100 will then interrogate the PD to see if a classification signature is present. The classification signature is used to determine the amount of power the PD will draw and limits the output power accordingly (see Table 2). It is optional for the PD to present a classification signature and the Ag6100 will default to Class 0 if the PD does not present one. If the Ag6100S sees a current over 48mA it will detect this as ‘Over Current’ and will retry the signature after a 2 second delay.

Table 2 shows the measured current limits that the Ag6100 uses to assign a classification value.

Measured Current	Classification
0mA to 6.5mA	Class 0
>6.5mA to 14.5mA	Class 1
>14.5mA to 23mA	Class 2
>23mA to 33mA	Class 3
>33mA to 48mA	Class 4

Table 2: Classification Table

6.3 Maintain Power Signature

On successful completion of a valid signature (and classification) the Ag6100 will apply main power to the Port output and the STATUS output will go to Logic 1.

Once main power has been applied, the Ag6100 will constantly monitor the PD to ensure that it is still connected; this is referred to as the Maintain Power Signature (MPS).

The Ag6100 uses the dc detection method of MPS and will remove power if the current drawn falls below the detect threshold. If the Ag6100 Port output current is $\geq 10\text{mA}$ the output will remain on. If the Port output current is $\leq 5\text{mA}$ the output will be turned off and the Ag6100 will return to the signature cycle (looking for a valid signature).

6.4 Output Current Limits

The Ag6100 has two over current limits - Current Limit 1* and Current Limit 2*.

The Ag6100 will allow the Port output to exceed Current Limit 1 (but not Current Limit 2) for a short duration – T_{LIM1} *. If the Port output continues to exceed Current Limit 1; the output power will be removed and the STATUS output will indicate an over-current fault (See Section 7 – STATUS Output).

If the output exceeds Current Limit 2, the Ag6100 will remove power (without waiting for T_{LIM}) and the STATUS output will indicate an over-current fault.

*Note: See Section 9.3 Electrical Characteristics

6.5 Output Power

The Ag6100-S is capable of delivering up to 39W, when supplied with its maximum input voltage of 57V.

Please note this is not the power available at the input of the Powered Device (PD). There are cable, connector and polarity protection losses to be taken into account.

7. STATUS Output

The STATUS output pin is at Logic 0 when the Port output is disconnected. After completion of a valid signature (and classification) the STATUS output will go to Logic 1 at the same time as the Port output applies main power.

When the Port output is disconnected the STATUS output will go to Logic 0, see Figure 8.

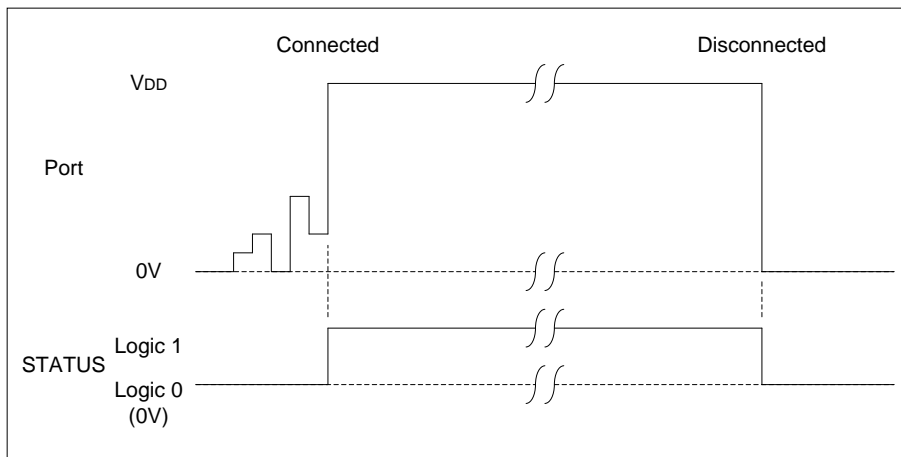

Figure 8: STATUS Output at Port Connect and Disconnect

In addition to the STATUS output reporting when the Port output is connected or disconnected, the STATUS output also reports when a fault has been detected.

When a short circuit fault is applied to the Port output, the STATUS output goes to Logic 0 for 100ms, then generating one 100ms pulse, before returning to Logic 0, see Figure 9.

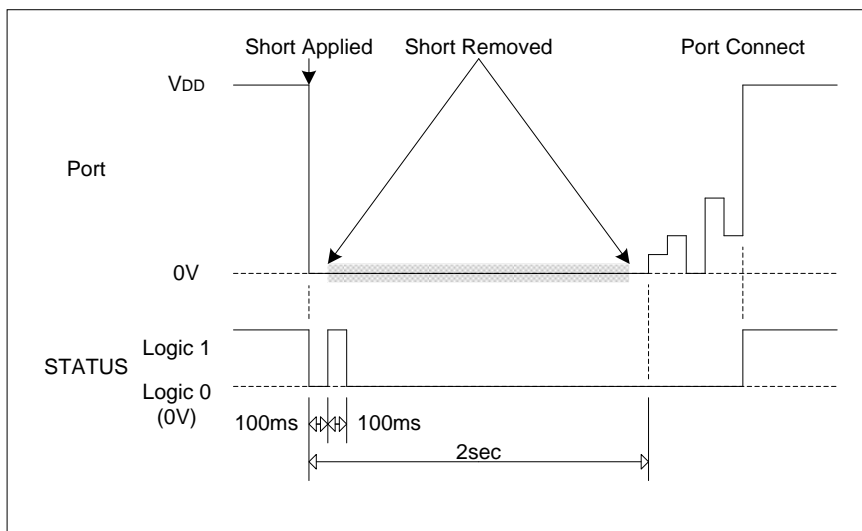

Figure 9: STATUS Output when a Short Circuit is applied to the Output Port

In the example shown in Figure 10, the short circuit is removed at some point before the next Signature and Classification and the Ag6100 resumes normal operation. If the short circuit is not removed the Ag6100 will not pass the next Signature and the Port output will remain off.

When an over-current fault is applied to the Port output, the STATUS output goes to Logic 0 for 100ms, then generating two 100ms pulses, before returning to Logic 0, see Figure 10.

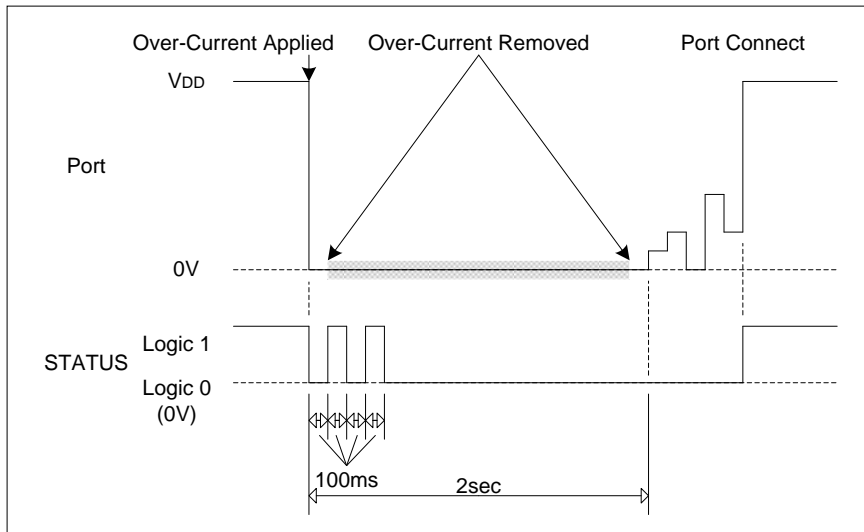

Figure 10: STATUS Output when an Over-Current is applied to the Output Port

In the example shown in Figure 10, the over-current is removed at some point before the next Signature and Classification and the Ag6100 resumes normal operation. If the short circuit is not removed the Ag6100 will start up again and repeat the fault shutdown cycle until the over-current fault is removed, see Figure 11.

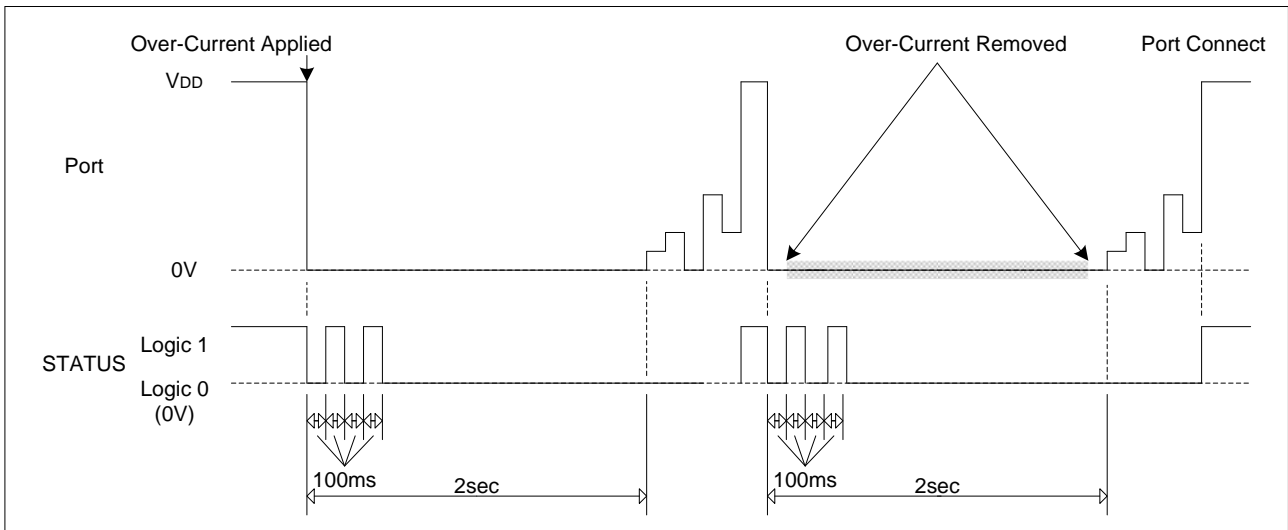

Figure 11: STATUS Output when an Over-Current fault is not removed

The slow duration of the pulses is to allow for an LED to be connected for visual indication of the output status as shown in Figure 12:

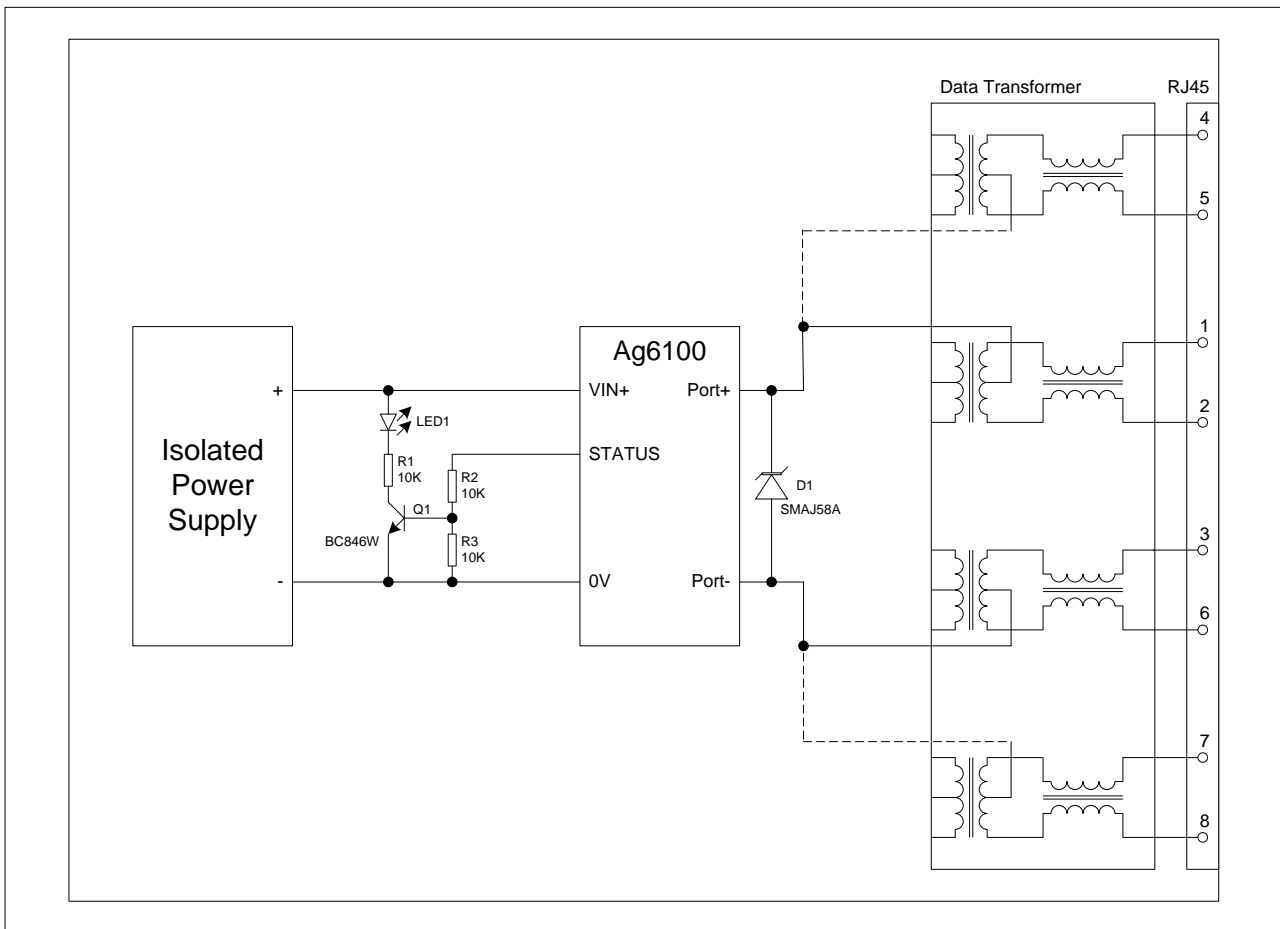

Figure 12: STATUS Output Configuration

8. Protection

8.1 Input Protection

The Ag6100 has built-in Tranzorb diode across its input, to protect the module from transients from the power supply.

8.2 Output Short-Circuit Protection

In addition to the over-current protection the Ag6100 has built-in output short-circuit protection.

If the Port output is shorted, the Ag6100 will limit the current and remove the power, the STATUS output will indicate a short-circuit fault.

To protect the module from voltage transients coming from the RJ45 cable we would recommend fitting a SMAJ58 or higher on the Ag6100 output as shown in Figure 12.

9. Electrical Characteristics

9.1 Absolute Maximum Ratings¹

	Parameter	Symbol	Min	Max	Units
1	DC Supply Voltage	V_{DD}	-0.3	60	V
2	Storage Temperature	T_S	-40	+100	°C

Note 1: Exceeding the above ratings may cause permanent damage to the product. Functional operation under these conditions is not implied. Maximum ratings assume free airflow.

9.2 Recommended Operating Conditions

	Parameter	Symbol	Min	Typ	Max	Units
1	Input Supply Voltage	$V_{DD (Type1)}$	45		57	V
		$V_{DD (Type2)}$	50		57	V
2	Ag6100-S Operating Temperature -	T_{OP}	-40	25	85	$T_a / ^\circ C$

9.3 Electrical Characteristics

	Parameter	Sym	Min	Typ	Max	Units	Condition
1	V_{DD} Idle Supply Current	I_{DD}		8	15	mA	
2	Signature Detection Voltage	V_{SIGL}	2.7	4.5		V	
		V_{SIGH}		9	10.1	V	
3	Minimum Valid Signature	R_{SIGL}	15			kΩ	
4	Maximum Valid Signature	R_{SIGH}			32	kΩ	
5	Classification Voltage	V_{CLASS}	14.5		20.5	V	
6	Classification Mark Voltage	V_{MARK}	6.9		10	V	
7	Classification Threshold Current	I_{CLASS}	5.5	6.5	7.5	mA	Class 0 - 1
			13.5	14.5	15.5	mA	Class 1 - 2
			21.5	23	24.5	mA	Class 2 - 3
			31.5	33	34.9	mA	Class 3 - 4
			45.2	48	50.8	mA	Class 4 - Over-current
8	Maintain Power Signature	V_{MPS}	5		10	mA	
9	Maximum Output Power @ 57V	P_{MAX}		21 39		W W	Type 1 - ALL Type 2 - S
10	Current Limit 1	I_{LIM1}		375		mA	Type 1 - ALL
				684		m	Type 2 - S
11	Current Limit 2	I_{LIM2}		475		mA	Type 1 - ALL
				784		mA	Type 2 - S
12	Current Limit 1 Cut-Off Time	T_{LIM1}	50			ms	Type 1
			10			ms	Type 2
13	STATUS Output	V_{OH}		3.3		V	@ -3mA
		V_{OL}		0.3		V	@ 3mA