

Infineon Audiohub Nano Digital

User Manual

About this document

Scope and purpose

The user manual provides information about using and evaluating Infineon digital XENSIV™ MEMS microphones with the help of the **Audiohub Nano Digital** evaluation board. It familiarizes you with the evaluation board and guides you through the initial set-up and measurement.

Intended audience

Design, verification, test and software engineers can use this document to get an understanding of the functionality and connections of the **Audiohub Nano** evaluation board.

Table of contents

About this document	1
Table of contents	1
1 Introduction	2
1.1 Prerequisites.....	2
1.1.1 Hardware	2
1.1.2 Software	2
2 Features	3
2.1 Summary of features.....	3
2.2 Block diagram.....	3
3 Initial set-up	4
3.1 USB communication	4
3.2 Host computer set-up	4
3.3 Audacity software set-up	5
4 Evaluation board information	6
4.1 Connectors	6
4.2 Test points	7
4.3 Volume Unit (VU) meter display with onboard LEDs	7
4.4 Operating mode and gain configuration with mode switch.....	7
4.5 Secondary PDM interface.....	8
Revision history	9

1 Introduction

This document serves as a manual for the evaluation of up to two Infineon digital XENSIV™ MEMS microphones using the Audiohub Nano board in mono or stereo output. The evaluation board provides a USB audio interface to stream audio data from microphones with any audio recording and editing software.

1.1 Prerequisites

1.1.1 Hardware

- Infineon Audiohub Nano evaluation board
- Infineon digital XENSIV™ MEMS microphone flex kit
- Micro-USB cable

1.1.2 Software

- Audio editing software that supports 48 kHz and 24-bit recording
- FT9xx programming utility for firmware update (optional)

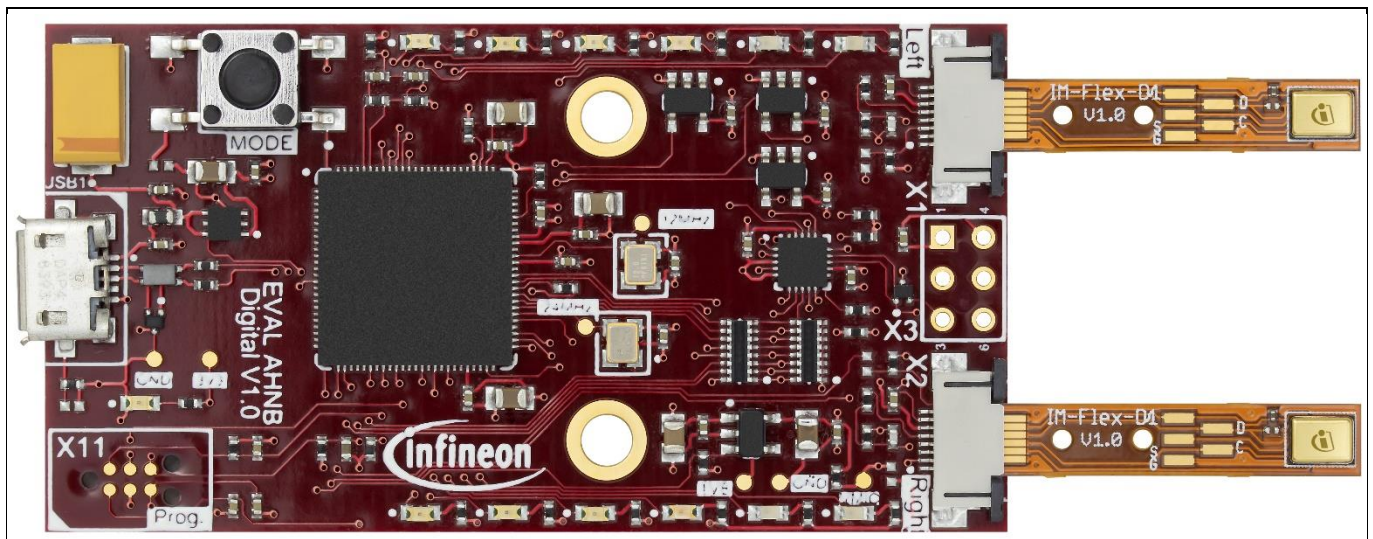

Figure 1 Audiohub Nano Digital with left and right flex connectors for digital XENSIV™ MEMS Microphones

Features

2 Features

2.1 Summary of features

- Audio streaming over USB interface
- 48 kHz sampling rate
- 24-bit audio data (stereo)
- Two different power modes (high power and low poer mode, see section 4.4)
- Four different gain configurations indicated by onboard LEDs (see section 4.4)
- Volume unit meter indication by onboard LEDs (see section Volume Unit (VU) meter display with onboard LEDs (see section 4.3)
- Powered through Micro-USB

2.2 Block diagram

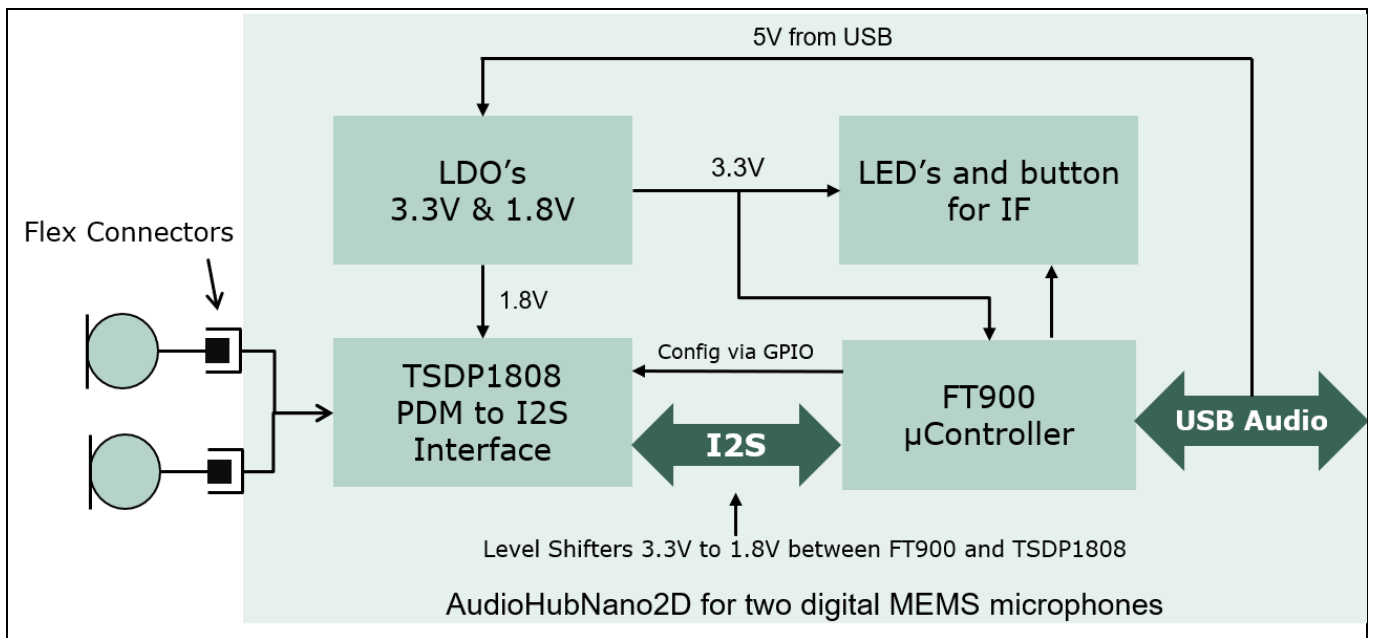

Figure 1 Audiohub Nano block diagram

3 Initial set-up

To get started insert the XENSIV™ MEMS Microphones from your flex kit to the flex connectors (left and right), as shown in **Error! Reference source not found..**

3.1 USB communication

The evaluation board is powered through the Micro-USB port. Connect the board to the host computer via USB. For streaming the audio data from the board select AudioHubNano2D as your audio input device. Any audio recording or editing software (e.g. Audacity) can be used to record and evaluate the microphones, see Figure 3.

3.2 Host computer set-up

To enable the best performance of USB audio recording, the processor resources allocation should be adjusted to the best performance of background services. Please follow these steps to enable this in the Windows 10 operating system.

- Go to *Control Panel > System and Security > System > Advanced system settings*.
- Go to the *Advanced* tab and click on the *Settings* button under *Performance*.
- In the pop-up window of *Performance options*, go to the *Advanced* tab, select *Background services* and apply changes as shown in Figure 2.

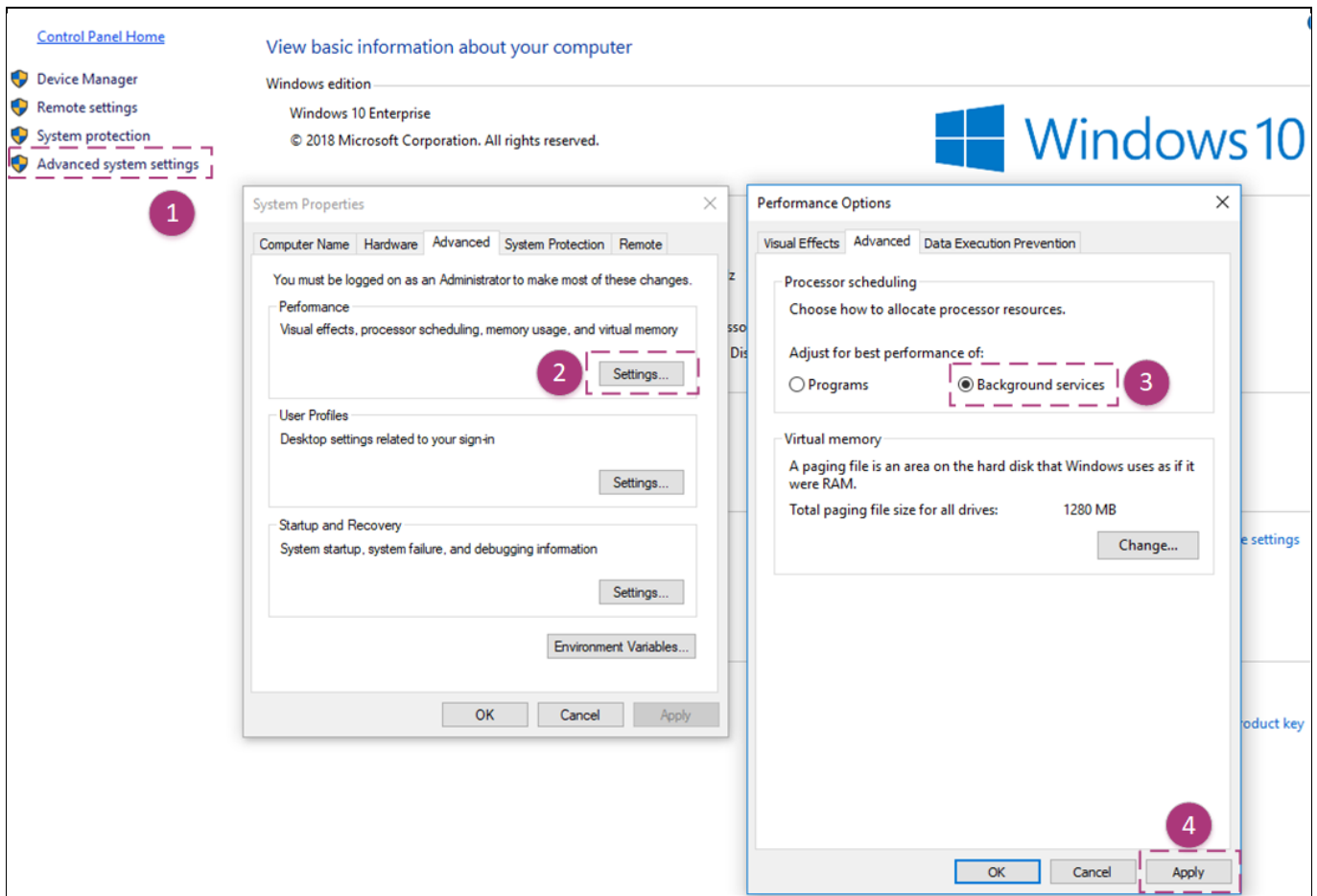

Figure 2 Host computer system settings

3.3 Audacity software set-up

Audacity is a free and open-source audio editor and recording application. Select the audio source as Audiohub Nano in the recording software, as shown in Figure 3. The recording channel can be selected as either mono or stereo.

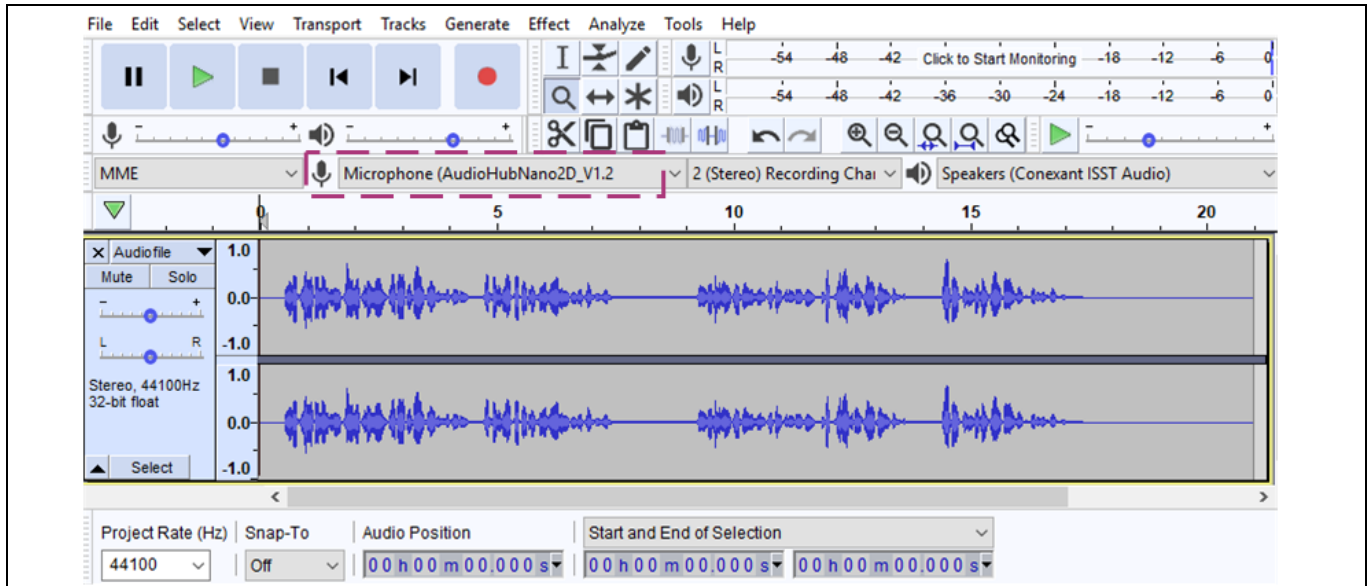

Figure 3 Recording from Audiohub Nano Digital in Audacity

4 Evaluation board information

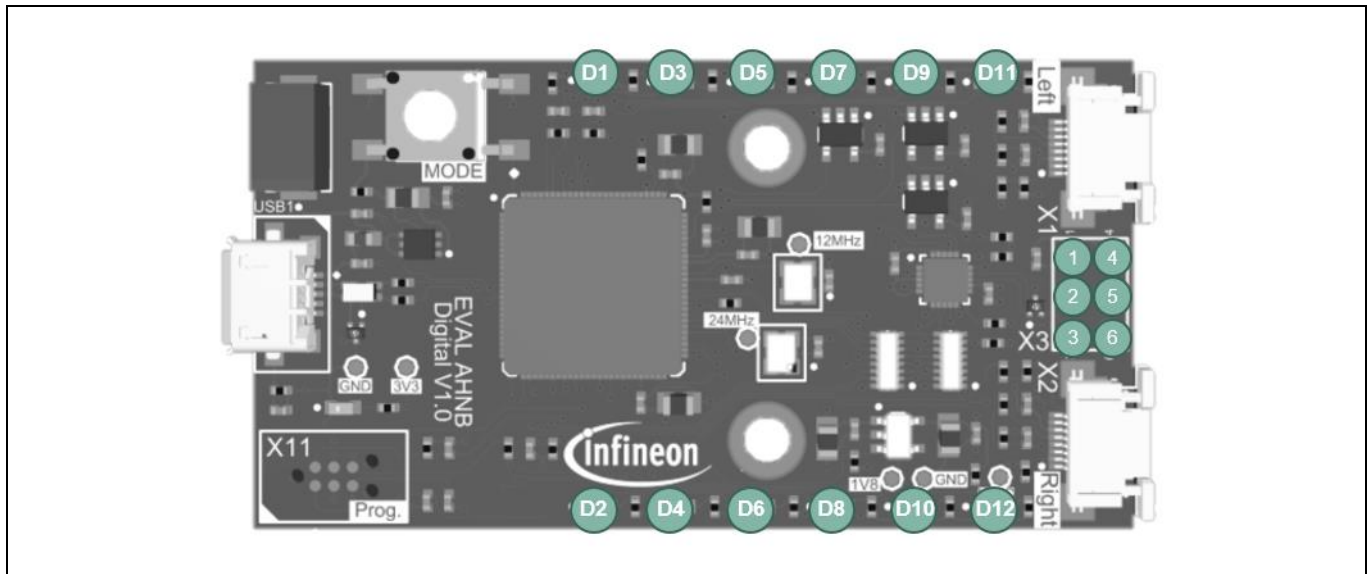

Figure 4 AudioHub Nano Digital Layout

4.1 Connectors

A list of the connectors provided by on the Audiohub Nano evaluation board can be found in **Table 1**. Furthermore, **Table 2** gives an overview of the respective pins.

Table 1 Connector list

Reference designator	Description
X1	Flex connector for left channel microphone connection
X2	Flex connector for right channel microphone connection
X3	Secondary PDM interface
X11	Programming connector
USB1	Micro-USB connector for power and audio streaming

Table 2 Connector X3 detailed pin-out

Pin number	Name	Description
1	VMIC	Microphone VDD
2	MIC DATA1	PDM data signal from microphone
3	MIC CLOCK	PDM clock signal to microphone
4, 5, 6	MGND	Microphone ground

4.2 Test points

Table 3 lists all the available test points for debugging on the Audiohub Nano evaluation board.

Table 3 Test point description

Test point	Name	Description
TP1	NetQ1_3	12 MHz from oscillator Q1
TP2	I2S_CLK24	24.566 MHz clock from oscillator Q1 from I ² S interface
TP4	VDD3V3	3.3 V power rail
TP5	VDD1V8	1.8 V power rail
TP6	VMIC	Microphone power supply
TP7	GND	Digital ground
TP8	GND	Digital ground

4.3 Volume Unit (VU) meter display with onboard LEDs

The onboard LEDs turn on based on the measured sound pressure levels (dB SPL). The LEDs work as a Volume Unit (VU) meter when streaming the audio data. The threshold for the LED turn-on is based on the sound pressure level during the audio streaming, as shown in **Table 4**. In case only one microphone is connected both LED bars will indicate the volume of the mono audio stream.

Table 4 VU meter setting based on sound pressure level

LED reference	dB SPL *	dBFS	LED color
D1, D2	50	-80	green
D3, D4	65	-65	green
D5, D6	80	-50	green
D7, D8	94	-36	yellow
D9, D10	110	-20	orange
D11, D12	125	-5	red

4.4 Operating mode and gain configuration with mode switch

The mode switch push button S1 can be used to switch through various configurations in a sequence. The settings are defined for configuring the power modes:

- *normal mode* and
- *low power mode*.

The mode switch button also enables different pre-defined gain configurations on the audio data stream. The gain settings can be configured when the evaluation board is in idle mode and not recording the audio stream.

On power-on, the evaluation board is set to normal mode with 0 dB gain by default. This configuration is indicated by LED D3.

Table 5 describes the different gain configurations and power modes that can be changed with the mode switch push button.

Table 5 **Operating mode and gain configuration LED reference**

LED reference	Operating mode	Gain configuration (dB)
D3	Normal power mode	0
D5		12
D7		18
D9		24
D4	Low power mode	0
D6		12
D8		18
D10		24

4.5 **Secondary PDM interface**

The connector X3 can be used to connect an external PDM microphone to the evaluation board. Both flex connectors X1 and X2 are disabled when the microphone is connected to X3. **Table 2** describes the detailed pin-out of the connector X3.

Revision history

Document version	Date of release	Description of changes
V01_0	2019-10-29	Initial release
V01_1	2022-07-28	Updated block diagram