

Compact reference design kit for robotics and automation based on STSPIN32F0A



Features

- 36 V/6 A_{peak} power stage
- STSPIN32F0A advanced 3-phase motor controller embedding Cortex-M0 MCU
- STL7DN6LF3 60 V, 35 mΩ Dual N-channel MOSFETs
- Hall sensors
- Position control loop based on Field Oriented Control
- MODBUS communication protocol through RS-485
- Extremely compact footprint (40 mm x 40 mm)
- maxon EC-i 40 100 W 3-phase brushless DC motor
- maxon ENX 16 EASY 1024-pulse incremental encoder

Description

The EVALKIT-ROBOT-1 is an evaluation kit offering a ready-to-use servo brushless solution.

Thanks to the high integration level of the STSPIN32F0A, the control board provides a powerful power stage, the analog circuitry implementing current sensing and overcurrent protection and a Cortex-M0 microcontroller performing a Field-Oriented Control with closed-loop positioning. All packed into a 40 mm x 40 mm footprint.

The maxon EC-i 40 motor, thanks to the optimized magnetic circuit, offers a very high torque density and very low cogging torque. In combination with the maxon ENX 16 EASY 1024 pulses incremental encoder, it is an excellent choice for reliable, robust and high-precision position and speed control.

Product status link

[EVALKIT-ROBOT-1](#)

1 Specifications

Table 1. Control board specifications

Parameter		Value
Supply voltage	Nominal	36 V
	Full operating range	from 12 V to 45 V
Maximum current	DC ⁽¹⁾	3 A
	Peak	6 A
RS485 maximum baud rate		20 Mbps
RS485 differential input voltage	Differential	± 12 V
	Common mode	- 7 V to 12 V
Encoder inputs	Differential	± 7 V
	Common mode	± 7 V

1. Actual maximum current may be limited by power dissipation

Table 2. Motor specifications

Parameter		Value
Nominal voltage		36 V
Speed	Nominal	3950 rpm
	No load	4550 rpm
Torque	Nominal	207 mNm
	Stall	3160 mNm
Current	Nominal	2.72 A
	Stall	42.2 A
Phase resistance		0.853 Ω
Phase inductance		0.675 mH
Rotor inertia		44 gcm ²
Pole pairs		7

Figure 1. Motor operating range

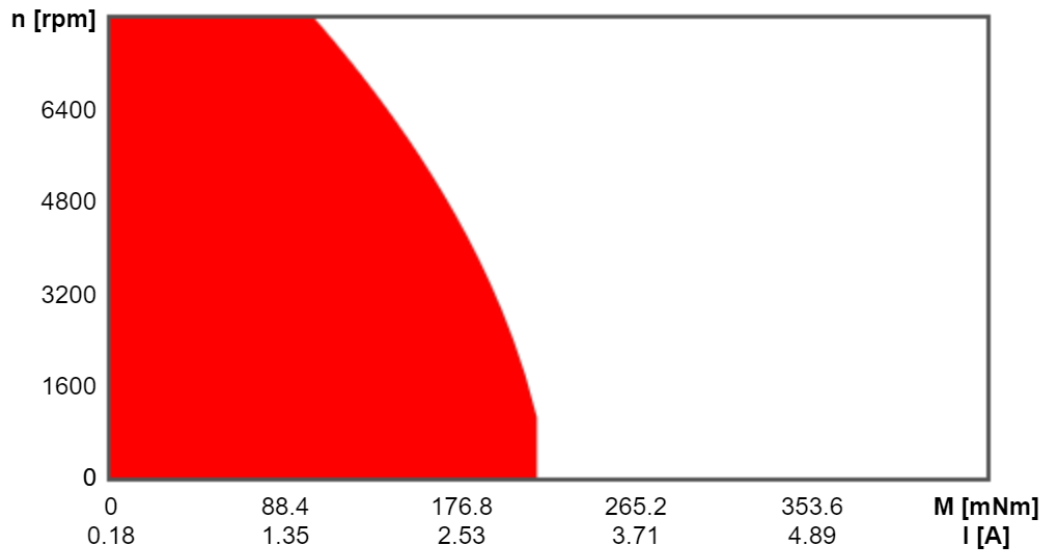

Continuous operation range

Short term operation range

Table 3. Encoder specifications

Parameter	Value
Supply voltage	5 V
Supply current	22 mA
Pulses per turn	1024
Max speed	30 krpm

Figure 2. Motor and encoder connectors drawings

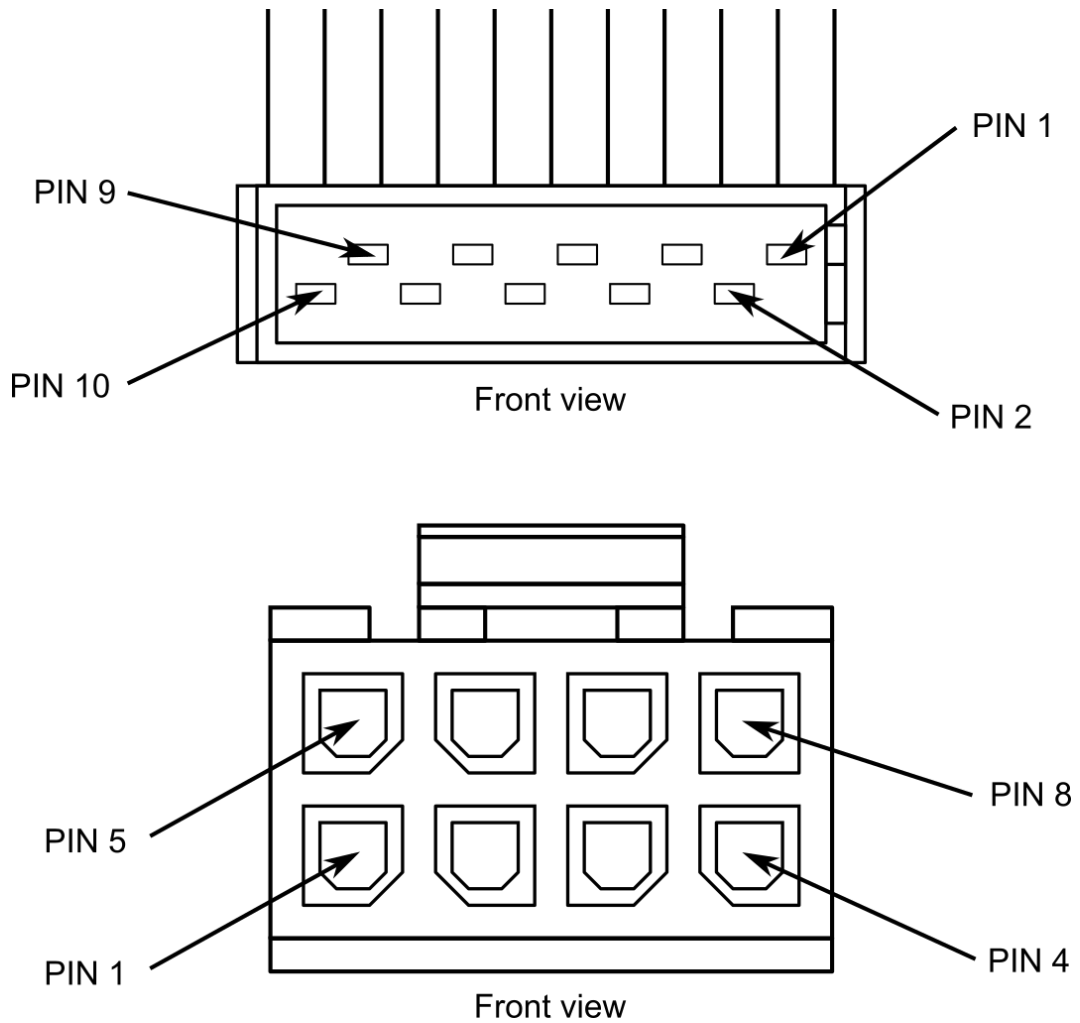

Table 4. Motor and Hall-effect sensors connector

Pin	Connection
1	Hall-effect sensor 1
2	Hall-effect sensor 2
3	Hall-effect sensor 3
4	Hall-effect sensors supply
5	Motor winding 1
6	Motor winding 2
7	Motor winding 3
8	Hall-effect sensors ground

Table 5. Encoder connector

Pin	Connection
1	Not connected
2	Encoder supply
3	Encoder ground
4	Not connected
5	Quadrature output channel A-
6	Quadrature output channel A+
7	Quadrature output channel B-
8	Quadrature output channel B+
9	Zero index channel I-
10	Zero index channel I+

Figure 3. Schematic board 1

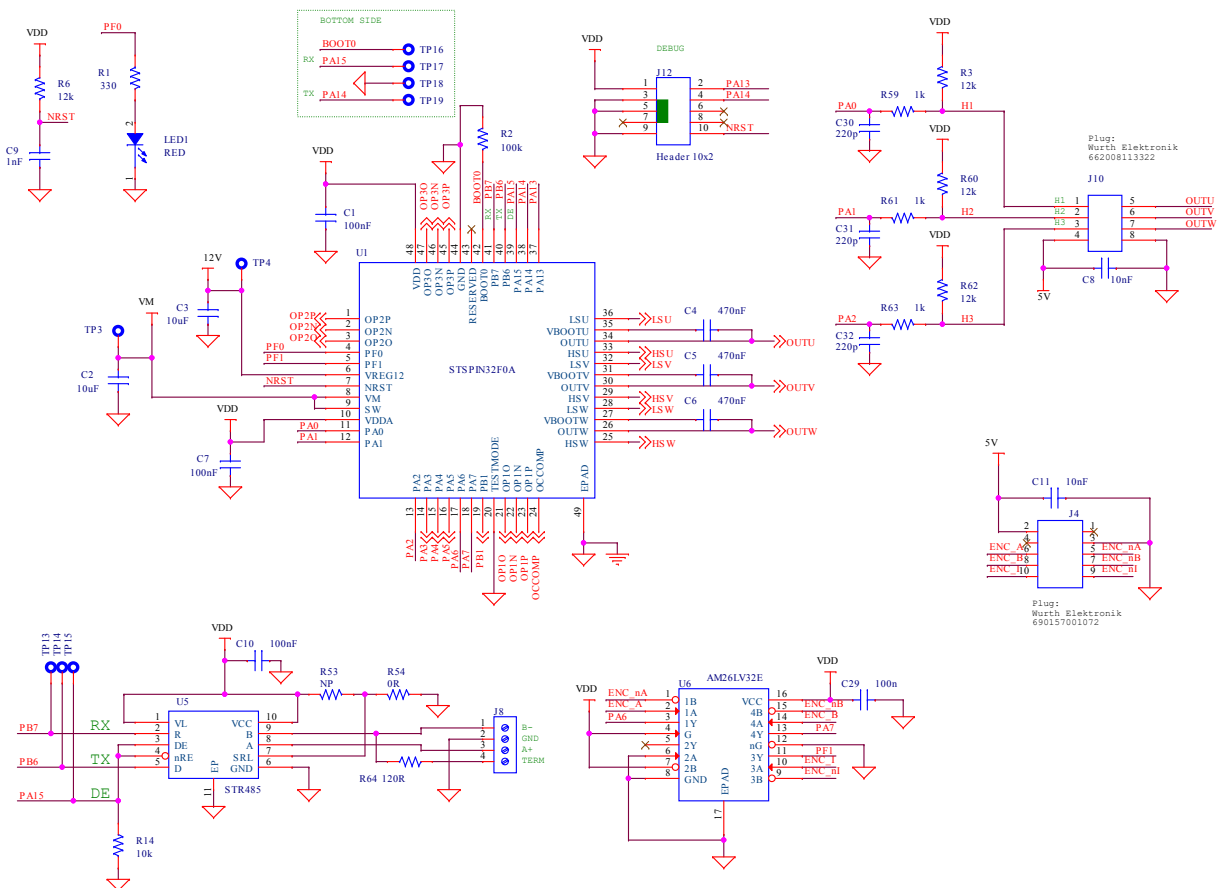

Figure 4. Schematic board 2

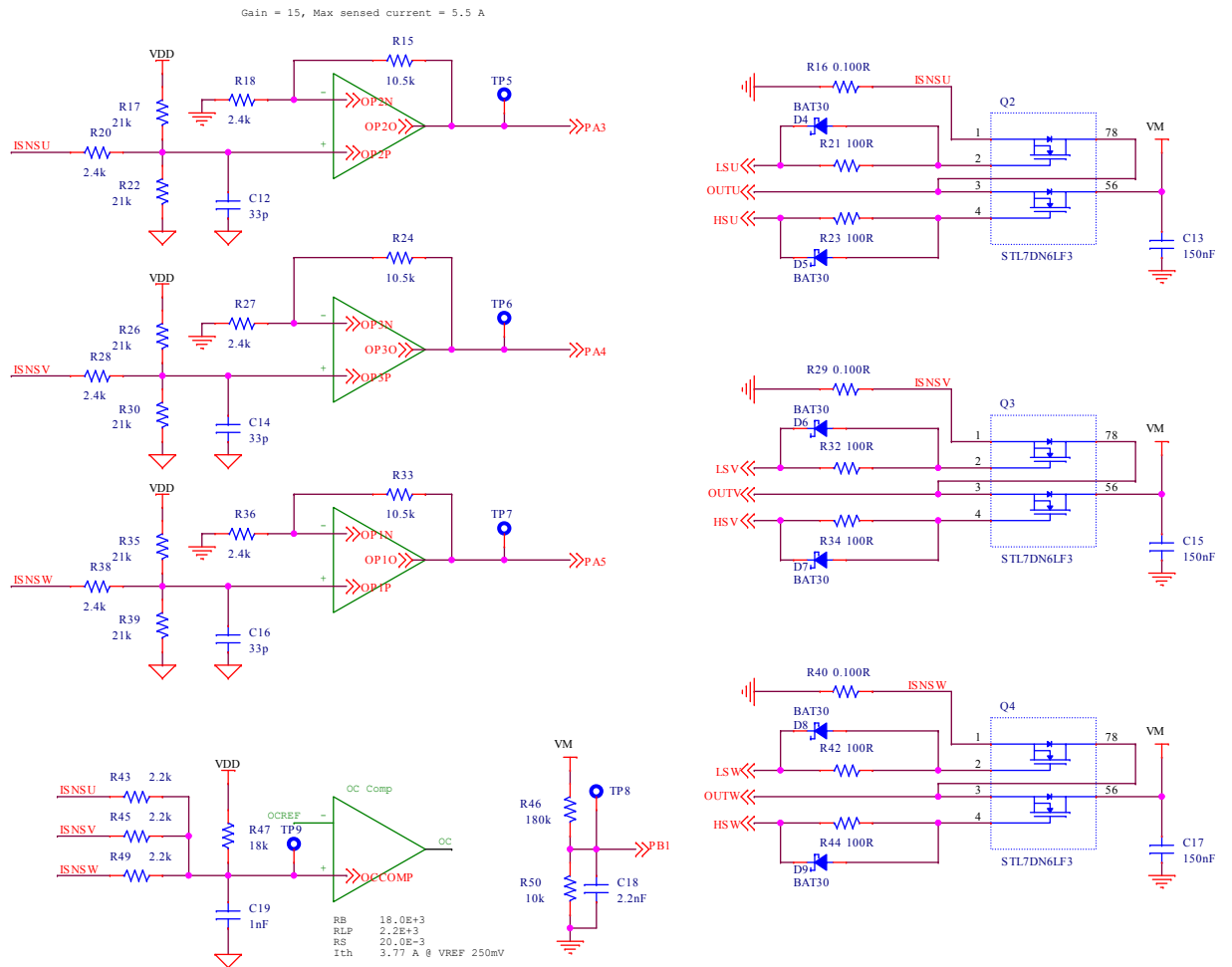
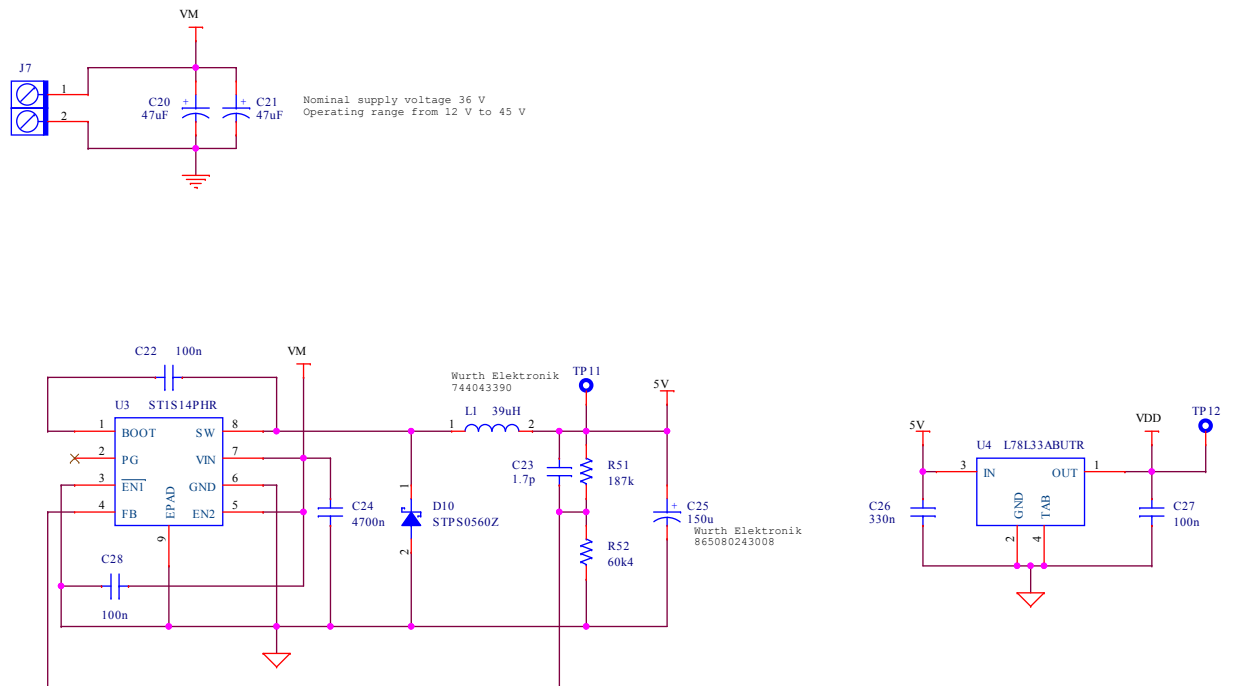

Figure 5. Schematic board 3

Table 6. Bill of materials

Item	Quantity	Part reference	Part description	Value
1	3	C1, C7, C10	SMT ceramic capacitor	100 nF
2	1	C2	SMT ceramic capacitor	10 μ F
3	1	C3	SMT ceramic capacitor	10 μ F
4	3	C4, C5, C6	SMT ceramic capacitor	470 nF
5	2	C8, C11	SMT ceramic capacitor	10 nF
6	2	C9, C19	SMT ceramic capacitor	1 nF
7	3	C12, C14, C16	SMT ceramic capacitor	33 pF
8	3	C13, C15, C17	SMT ceramic capacitor	150 nF
9	1	C18	SMT ceramic capacitor	2.2 nF
10	2	C20, C21	SMT electrolytic capacitor	47 μ F
11	2	C22, C28	SMT ceramic capacitor	100 nF
12	1	C23	SMT ceramic capacitor	1.7 pF
13	1	C24	SMT ceramic capacitor	4700 nF
14	1	C25	SMT electrolytic capacitor	150 μ F
15	1	C26	SMT ceramic capacitor	330 nF
16	2	C27, C29	SMT ceramic capacitor	100 nF
17	3	C30, C31, C32	SMT ceramic capacitor	220 pF
18	6	D4, D5, D6, D7, D8, D9	Small signal Schottky diode	BAT30
19	1	D10	Schottky rectifier	STPS0560Z
20	1	J4	WR-MM female connector with latch w/o polarization 10 poles	Flat connector 10 pole

Item	Quantity	Part reference	Part description	Value
21	1	J7	Horizontal terminal block pitch 3.50 mm	Terminal 2P_screw p3.5mm
22	1	J8	Terminal block T.H. 4 positions, 2.54 mm	Terminal 4P_screw p2.54mm
23	1	J10	WR-MPC3 - 3.00MM male dual-row right angle 8 poles	Connector 8 pole w polarization
24	1	J12	WR-PHD 1.27 mm dual pin header, H=3.80 mm	Header 10x2
25	1	LED1	WL-SMCW SMT red LED	red
26	1	L1	WE-TPC SMD Tiny Power Inductor	39 μ H
27	3	Q2, Q3, Q4	Dual N-channel 60 V, 35 m Ω typ., 6.5 A STripFET™ F3 power MOSFET	STL7DN6LF3
28	1	R1	SMT resistor	330 Ω
29	1	R2	SMT resistor	100 k Ω
30	4	R3, R6, R60, R62	SMT resistor	12 k Ω
31	1	R14	SMT resistor	10 k Ω
32	3	R15, R24, R33	SMT resistor	10.5 k Ω
33	3	R16, R29, R40	Thick film chip resistors	0.100 Ω
34	6	R17, R22, R26, R30, R35, R39	SMT resistor	21 k Ω
35	6	R18, R20, R27, R28, R36, R38	SMT resistor	2.4 k Ω
36	6	R21, R23, R32, R34, R42, R44	SMT resistor	100 Ω
37	3	R43, R45, R49	SMT resistor	2.2 k Ω
38	1	R46	SMT resistor	180 k Ω
39	1	R47	SMT resistor	18 k Ω
40	1	R50	SMT resistor	10 k Ω
41	1	R51	SMT resistor	187 k Ω
42	1	R52	SMT resistor	60.4 k Ω
43	1	R53	SMT resistor	NP
44	1	R54	SMT resistor	0 Ω
45	3	R59, R61, R63	SMT resistor	1 k Ω
46	1	R64	SMT resistor	120 Ω
47	16	TP3, TP4, TP5, TP6, TP7, TP8, TP9, TP11, TP12, TP13, TP14, TP15, TP16, TP17, TP18, TP19	40 mils PAD	TP-SMD-diam1_016mm
48	1	U1	STSPIN32F0A three-phase controller with MCU	STSPIN32F0A
49	1	U3	Up to 3 A step-down switching regulator	ST1S14PHR
50	1	U4	Positive Voltage Regulator	L78L33ABUTR
51	1	U5	3.3V RS485 compatible with 1.8V I/Os and selectable speed 20Mbps or 250kbps	STR485

Item	Quantity	Part reference	Part description	Value
52	1	U6	Quadruple differential line receiver	AM26LV32E

2 Waste and Recycling

The evaluation board is not to be disposed of as urban waste. At the end of its life cycle, differentiated waste collection must be followed. Consult the local authorities for more information on the proper disposal channels and recycling centers. It is mandatory to collect separately the evaluation board and make sure it is delivered to the appropriate waste management and recycling centers. As of 15 August 2018, in all countries belonging to the European Union, the evaluation board is subject to the requirements of WEEE Directive **2012/19/EU**, and therefore it is forbidden to dispose of the evaluation board as undifferentiated waste or with other domestic waste. Incorrect disposal of the evaluation board may cause damage to the environment and may incur fines based on specific countries' rules, regulations, and laws.

Revision history

Table 7. Document revision history

Date	Version	Changes
09-Oct-2019	1	Initial release.
16-Dec-2019	2	Cover image updated.
03-Feb-2020	3	Correct the unit of Maximum Current in Table 1

Contents

1	Specifications	2
2	Waste and Recycling	10
	Revision history	11
	Contents	12
	List of tables	13
	List of figures.....	14

List of tables

Table 1.	Control board specifications	2
Table 2.	Motor specifications	2
Table 3.	Encoder specifications	3
Table 4.	Motor and Hall-effect sensors connector	4
Table 5.	Encoder connector	5
Table 6.	Bill of materials	7
Table 7.	Document revision history	11

List of figures

Figure 1.	Motor operating range	3
Figure 2.	Motor and encoder connectors drawings	4
Figure 3.	Schematic board 1	5
Figure 4.	Schematic board 2	6
Figure 5.	Schematic board 3	7