

EVAL-M1-099M-C User Manual

iMOTION™ Modular Application Design Kit

About this document

Scope and purpose

This application note provides an overview of the evaluation board EVAL-M1-099M including its main features, key data, pin assignments and mechanical dimensions.

EVAL-M1-099M is an evaluation-board as part of the iMOTION™ Modular Application Design Kit Platform. This board features and demonstrates Infineon's advanced Motion Control Engine (MCE) technology for permanent magnet motors drive over the full speed range.

The evaluation board EVAL-M1-099M was developed to support customers during their first steps designing applications with running any permanent magnet motor via sensorless sinusoidal control.

Important Note: EVAL-M1-099M-C is the orderable part number for the kit which contains only EVAL-M1-099M MADK Control Board. In order to program, configure and debug the motor control systems based on EVAL-M1-099M, an Isolated Debugger Tool MCETOOLV2 is required. **MCETOOLV2 is not part of the EVAL-M1-099M-C kit and needs to be ordered separately.**

Intended audience

This application note is intended for all technical specialists who know motor control and high power electronics converter and this board is intended to be used under laboratory conditions.

Table of Contents







About this document.....	1
Table of Contents	1
1 Safety precautions.....	2
2 Introduction.....	3
3 Main features	4
3.1 Key data	5
3.2 IRMCK099 installer	8
4 Pin assignments	9
5 Schematics and Layout	11
5.1 Schematic Overview.....	11
5.2 Current feedback.....	12
5.3 AD port Input	13
5.4 PCB Layout	14
6 Bill of Materials of EVAL-M1-099M.....	17
7 Reference	19
Revision History	20

Safety precautions

1 Safety precautions

In addition to the precautions listed throughout this manual, please read and understand the following statements regarding hazards associated with development systems.

Table 1 **Precautions**

	<p>Attention: <i>The ground potential of the EVAL-M1-099M system is biased to a negative DC bus voltage potential. When measuring voltage waveform by oscilloscope, the scope's ground needs to be isolated. Failure to do so may result in personal injury or death and equipment damage</i></p>
	<p>Attention: <i>Only personnel familiar with the drive and associated machinery should plan or implement the installation, start-up and subsequent maintenance of the system. Failure to comply may result in personal injury and/or equipment damage.</i></p>
	<p>Attention: <i>The surfaces of the drive may become hot, which may cause injury.</i></p>
	<p>Attention: <i>EVAL-M1-099M system contains parts and assemblies sensitive to Electrostatic Discharge (ESD). Electrostatic control precautions are required when installing, testing, servicing or repairing this assembly. Component damage may result if ESD control procedures are not followed. If you are not familiar with electrostatic control procedures, refer to applicable ESD protection handbooks and guidelines.</i></p>
	<p>Attention: <i>A control board, incorrectly applied or installed, can result in component damage or reduction in product lifetime. Wiring or application errors such as under sizing the motor, supplying an incorrect or inadequate DC supply or excessive ambient temperatures may result in system malfunction.</i></p>
	<p>Attention: <i>Remove or connect this control board from or to the power drive. Wait three minutes after removing power from the power drive to discharge the bus capacitors. Do not attempt to service the drive until the bus capacitors have discharged to zero. Failure to do so may result in personal injury or death.</i></p>
	<p>Attention: <i>EVAL-M1-099M system is shipped with packing materials that need to be removed prior to installation. Failure to remove all packing materials which are unnecessary for system installation may result in overheating or abnormal operating condition.</i></p>

Introduction

2 Introduction

The EVAL-M1-099M evaluation board is a part of the iMOTION™ Modular Application Design Kit for drives (iMOTION™ MADK). In order to run a motor, the mating power board is required to interface this evaluation board.

The MADK platform is intended to use various power stages with different control boards. These boards can easily be interfaced through the 20 pins iMOTION™ MADK-M1 or the 30 pins iMOTION™ MADK-M3 interface connector. This board is equipped with 20 pins connector and for motor control only.

This evaluation board is designed to give comprehensible solutions of sensorless control of permanent magnet motors over the full speed range. It consists of IRMCK099M Motor Control IC, capable of 3-phase and three types of 2-phase modulation, JTAG and UART interface which are isolated via opto-isolation box (MCETOOLV2), and needs a single 3.3V supply. Required Isolation Box MCETOOLV2 is not part of the EVAL-M1-099M-C kit and needs to be ordered separately. For details of the isolation box please refer to its Application Note.

The EVAL-M1-099M evaluation board is available from Infineon and its distribution partners. The features of this board are described in the design feature chapter of this document, whereas the remaining paragraphs provide information to enable the customers to copy, modify and qualify the design for production according to their own specific requirements.

Environmental conditions were considered in the design of the EVAL-M1-099M. The design was tested as described in this document but not qualified regarding safety requirements or manufacturing and operation over the whole operating temperature range or lifetime. The boards provided by Infineon are subject to functional testing only.

Evaluation boards are not subject to the same procedures as regular products regarding Returned Material Analysis (RMA), Process Change Notification (PCN) and Product Discontinuation (PD). Evaluation boards are intended to be used under laboratory conditions by technical specialists only.

Figure 1 shows the evaluation board EVAL-M1-099M. This document explains the features and details of this board as well as control IC which is IRMCK099.

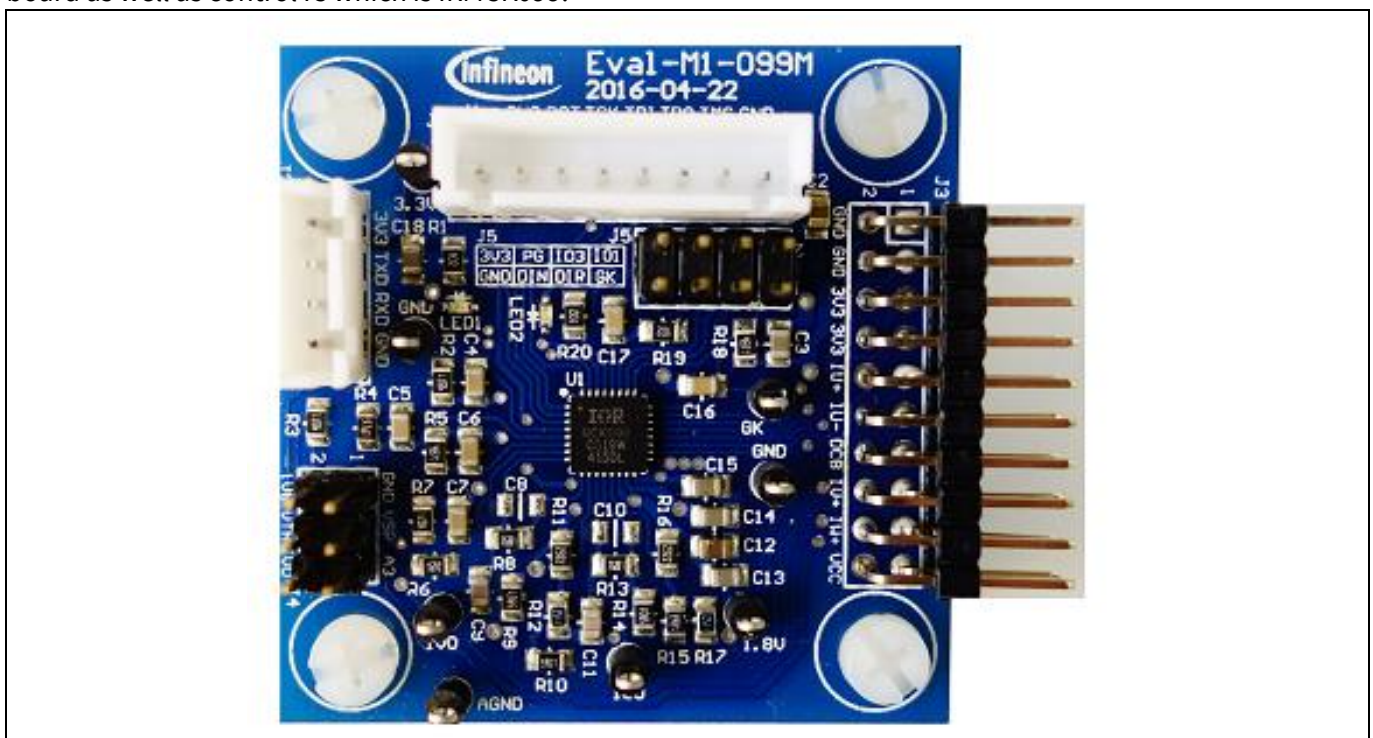

Figure 1 Evaluation board EVAL-M1-099M

Main features

3 Main features

EVAL-M1-099M is a control evaluation board for motor control application. The kit demonstrates Infineon's motion control IC technology.

Main features of Motion Control IC are:

- MCE (Motion Control Engine) - Dedicated computation engine for high efficiency sinusoidal sensorless motor control
- Supports both interior and surface permanent magnet motor
- Built-in hardware for single or leg shunt current feedback reconstruction
- Loss minimization Space Vector PWM
- Two-channel analog output
- JTAG programming port for emulation/ debugger
- Serial communication interface (UART)
- Internal 16 Kbyte OTP memory
- Multiple motor parameter support
- 3.3V single power supply
- V_{SP} control mode
- PG output
- Internal temperature sensing
- External NTC thermistor from power board temperature sensing support.

The evaluation board characteristics are:

- Complete kit for running any permanent magnet motor via sensorless sinusoidal control
- 3.3V single power supply
- JTAG and UART interface, isolated via opto-isolation box
- Capable of 3-phase and three types of 2-phase modulation
- RoHS complaint
- PCB is 45 x 45 mm and has two layers with 35 μ m copper each

Main features

3.1 Key data

Figure 2 shows a typical motor control application block diagram using the IRMCK099. The IRMCK099 provides a built-in closed loop sensorless control algorithm using the unique flexible Motion Control Engine (MCE) for permanent magnet motors. The MCE™ consists of a collection of control elements, motion peripherals, a dedicated motion control sequencer and internal memory to map internal signal nodes. IRMCK099 also employs a unique single shunt current reconstruction circuit in addition to two leg shunt current sensing circuit to eliminate additional analog/digital circuitry.

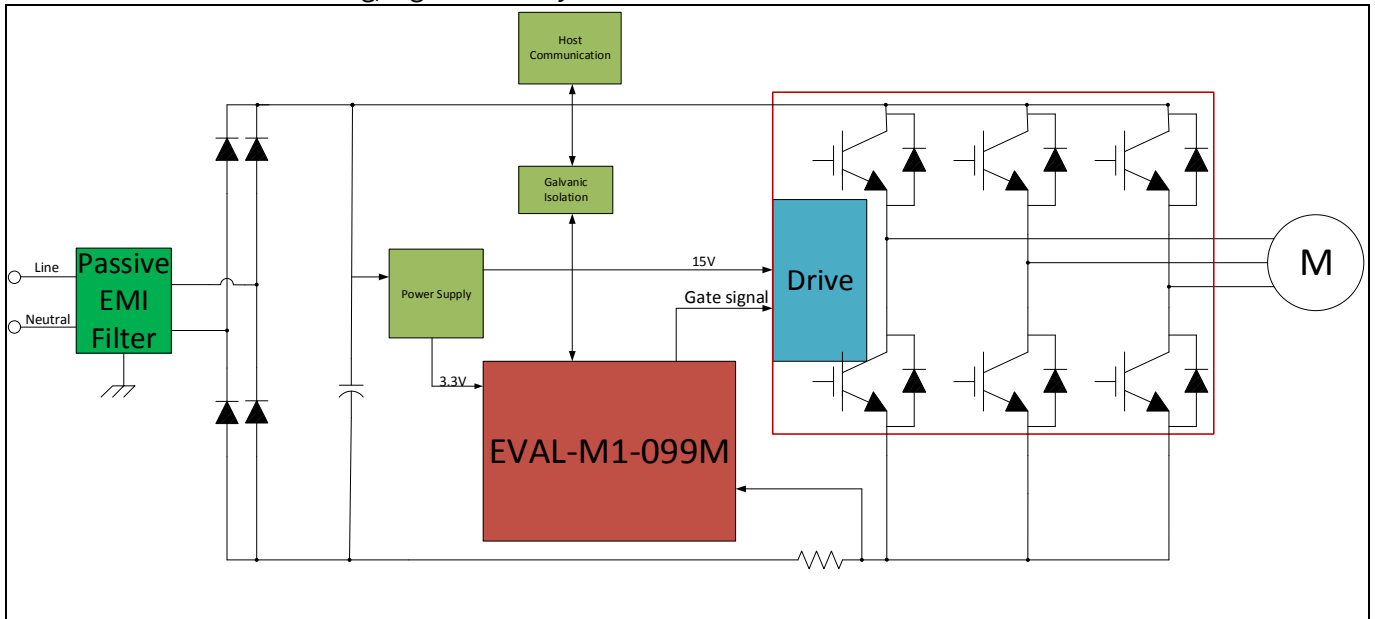

Figure 2 Typical Application Block Diagram Using IRMCK099

Main features

Figure 3 indicates pinout of IRMCK099. IRMCK099 contains 16 Kbytes of OTP program memory and comes in a compact 5mm x 5mm 32-pin QFN package.

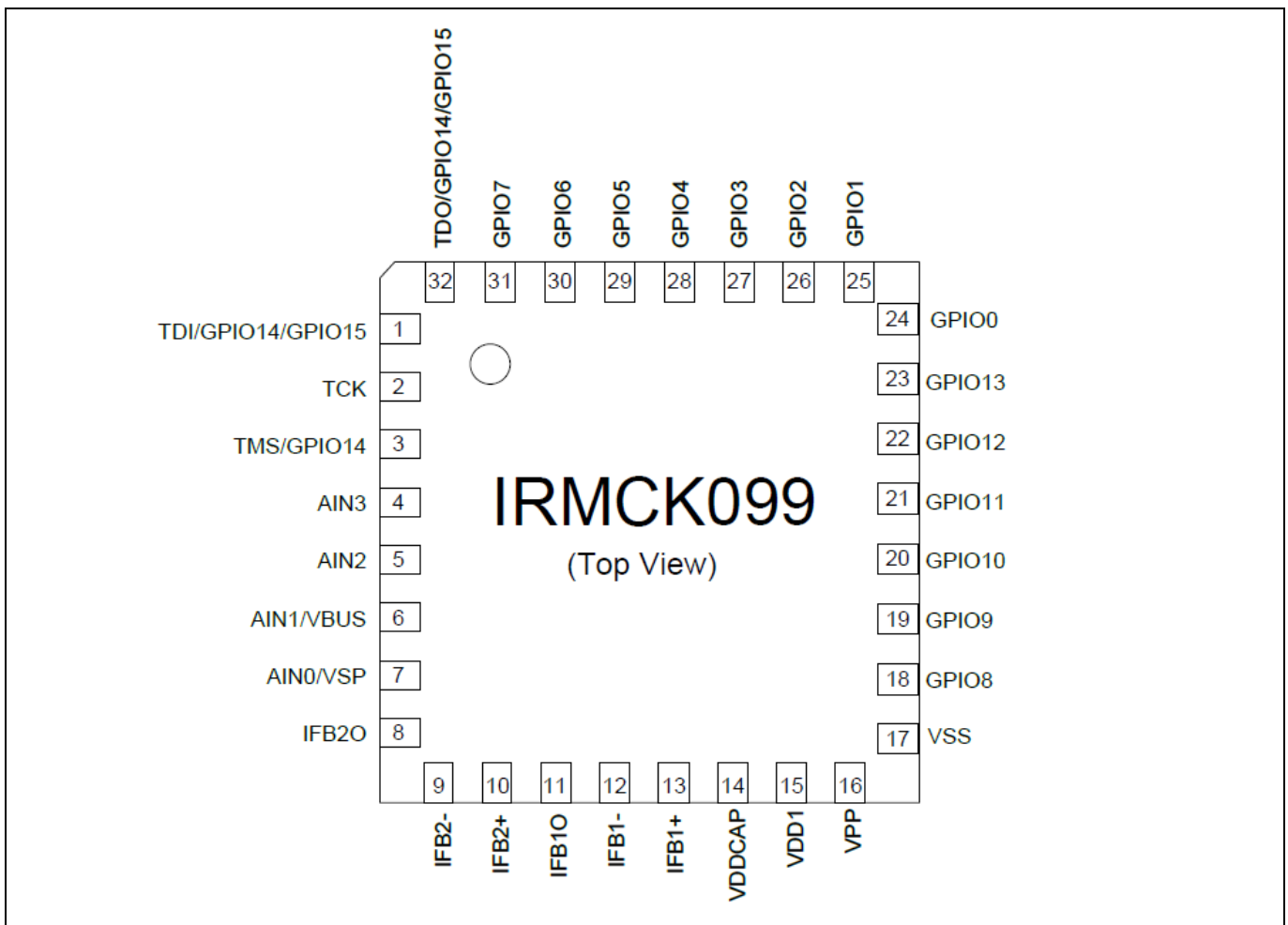

Figure 3 Pinout of IRMCK099

Table 2 depicts the important specifications of the evaluation board EVAL-M1-099M.

Table 2 Eval-M1-099M board specifications

Parameters	Values	Conditions / comments
Host Interface (Non isolation)		
UART(TXD RXD)	3.3V	Typical 5.76 kbps. single ended
TMS TDI TCK TDO	3.3V	Interface with FS2 or MCETOOLV2.0
8 Bit 2 Channel	0-3.3V output	GPIO Configurable to DAC
12 Bit	0-1.2V	
Input		
Voltage	3.3V	Power supply
DC Bus		
DC Bus Scaling	8.29 counts/v	Power board is supposed to have 2MΩ resistor

Main features

Parameters	Values	Conditions / comments
DC Bus sensing range	494.0V max	
Current feedback		
Current sensing device	50mV – 1100mV	Single shunt resistor Leg shunt resistor
Current Op-amp Configuration	Non-Inverting	
Current Op-amp Gain	1.302	
Resolution	12-bit	PCB design may reduce the resolution
Latency	1 pwm cycle	
Protections		
Internal current trip level	1.2V Average	
On board power supply		
1.8V	1.8V+/-5%	From IC for ADC reference
PCB characteristics		
Material	FR4, 1.6MM thickness Copper thickness = 1oz (35um)	
Dimension	45mmx45mm	
System environment		
Ambient temperature	0-70°C	95%RH Max (Non-Condensing)

Main features

3.2 IRMCK099 installer

In order to run this evaluation board, the user has to download iMOTION™ installer from Infineon iMOTION™ Web, it contains information about all the iMOTION™ control IC including IRMCK099 development software at Infineon web.

To download supporting software, pls goes to <http://www.infineon.com/imotion-software>. And all the updated version software is saved there.

Note: Currently, the user can download V02_01 and the patch file. See below link.

Or user can open below link to download IRMCK099 Installer V02_01 package.

http://www.infineon.com/dgdl/Infineon-99serieskitmceinstaller-SW-v02_01-EN.exe?fileId=5546d46253f65057015437c4a4e44339

And download V2.1 Patch Kit to update the install package. Then overwrite installed demo project.

http://www.infineon.com/dgdl/Infineon-99+Series+V2_1+Patch+Kit-SW-v02_01-EN.zip?fileId=5546d46256fb43b30157034e5b754664

Figure 4 the functional groups of the EVAL-M1-099M evaluation board.

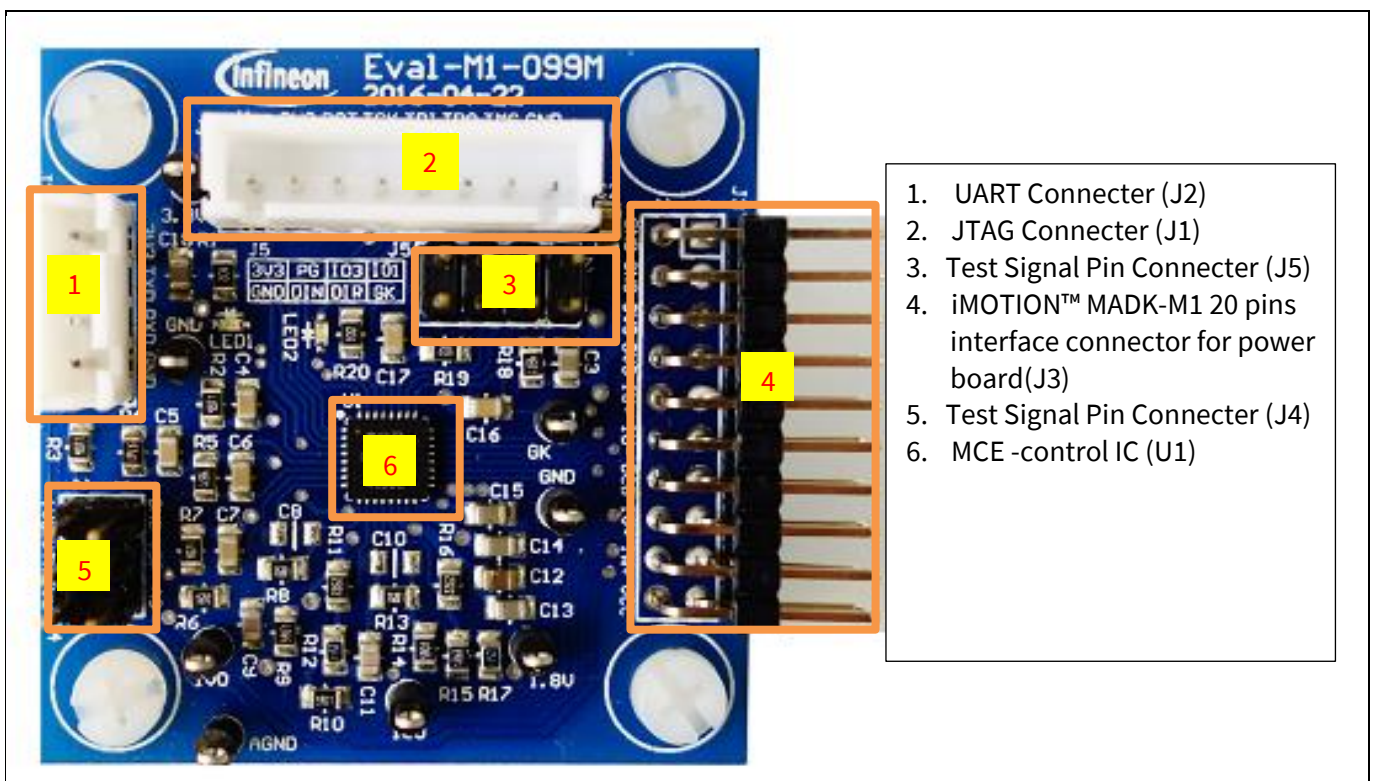

Figure 4 Functional groups of the EVAL-M1-099M evaluation board's top side

Pin assignments

4 Pin assignments

General information about the connectors of the Eval-M1-099M evaluation board is described below.

Table 3 and Table 4 include the details of JTAG and UART connectors.

Table 3 J1- UART Connector

S. No.	Pin	Details
1	GND	Ground
2	RXD	Input, Receive data to IRMCK099, can be configured to GPIO pins
3	TXD	Output, Transmit data from IRMCK099, can be configured to GPIO pins
4	+3.3V	+3.3V power supply

Table 4 J2-JTAG Connector

S. No.	Pin	Details
1	GND	Ground
2	TMS	TMS (test mode)
3	TDO	TDO (data output)
4	TDI	TDI (data input)
5	TCK	TCK (clock)
6	RST	Not Connected
7	+3.3V	+3.3V power supply(see Specification for max current)
8	VPP	Input ,OTP Programming voltage (for IRMCK099)

Table 5 provides the pin assignments of the iMOTION™ MADK-M1 20 pins interface connector J3. This connector is the interface to the power board.

Table 5 J3- iMOTION™ MADK-M1 20 pins interface connector for power board

Pin	Name	Pin Name Connectors
1	PWMUH	3.3 V compatible logic output for high side gate driver-Phase U
2	GND	Ground
3	PWMUL	3.3 V compatible logic output for low side gate driver-Phase1 U
4	GND	Ground
5	PWMVH	3.3 V compatible logic output for high side gate driver-Phase V
6	+3.3V	On board 3.3 V supply
7	PWMVL	3.3 V compatible logic output for low side gate driver-Phase V
8	+3.3V	On board 3.3 V supply
9	PWMWH	3.3 V compatible logic output for high side gate driver-Phase W
10	IU+	Shunt voltage phase U
11	PWMWL	3.3 V compatible logic output for low side gate driver-Phase W
12	IU-	Ground
13	GK	Gate kill signal – active low when over current is detected
14	DCBSENSE	DC bus positive voltage, scaled in 0-3.3 V range by a voltage divider

Pin assignments

Pin	Name	Pin Name Connectors
15	VTH	Thermistor input
16	IV+	Shunt voltage phase V
17	IV-	Ground
18	IW+	Shunt voltage phase W
19	IW-	Ground
20	VCC	Defined for 15 V Power Supply (not used in this board)

Table 6 and Table 7 include the details of test signal pin connectors.

Table 6 Test signals pin

Pin	Name	Pin Name Connectors
1	GND	Ground
2	1.8V	On board 1.8V supply
3	VSP	Input, Analog input channel 0 (0 – 1.25 V), also used for Standby Mode wake-up
4	VTH	Input, Voltage input of external temperature sense
5	AIN3	Input, Analog input channel 3 (0 – 1.25 V), needs to be pulled down to VSS if unused
6	IFBVO	Operational amplifier output for 2nd leg shunt resistor current sensing

Table 7 Test signals pin

Pin	Name	Pin Name Connector
1	GK	Output, Gatekill
2	GPIO1	Test IO pin
3	DIR	Input, motor direction select
4	GPIO3	Input, User mode select
5	DIN	Input, for Frequency control function
6	PG	Output, Pulse generate
7	GND	Ground
8	+3.3V	+3.3 V power supply

5 Schematics and Layout

To meet individual customer requirements and make the EVAL-M1-099M evaluation board a basis for development or modification, all necessary technical data like schematics, layout and components are included in this chapter.

5.1 Schematic Overview

Figure 5 shows the schematic of EVAL-M1-099M evaluation board with IRMCK099 controller.

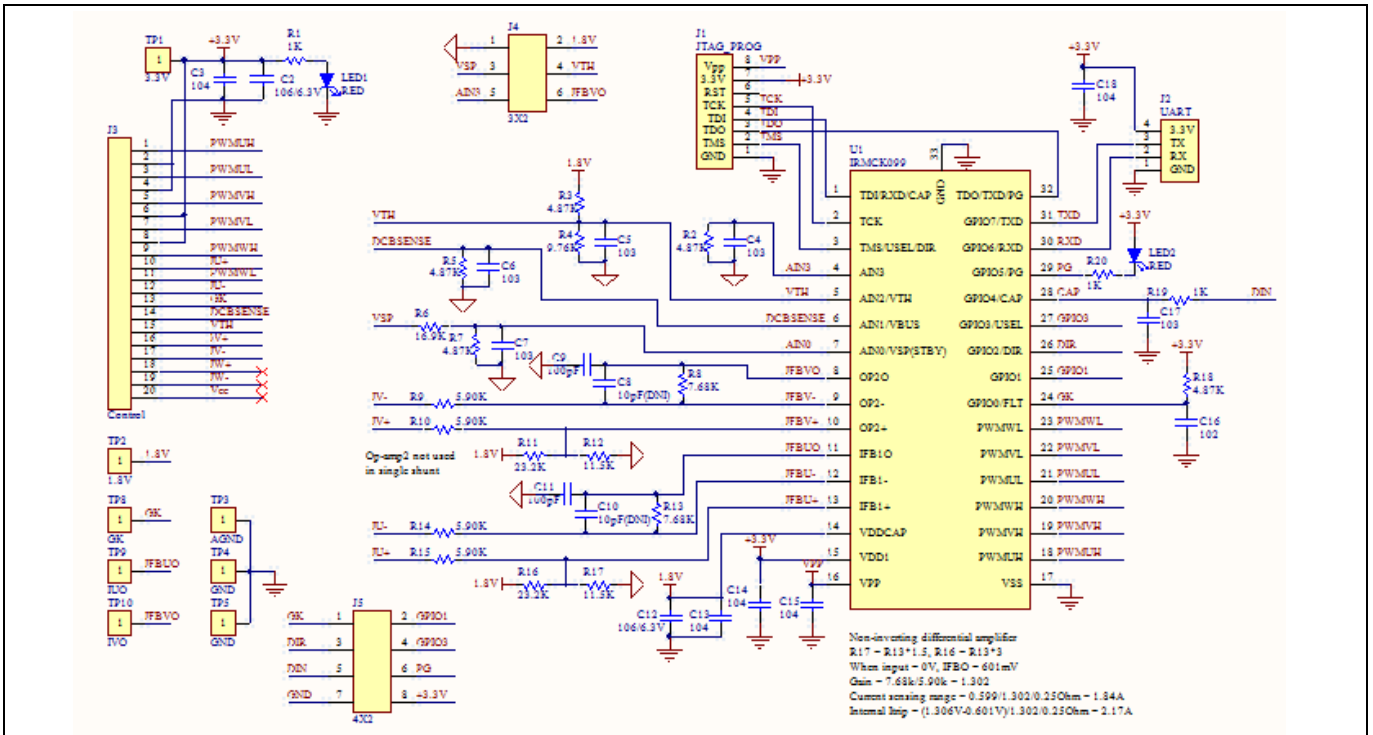

Figure 5 The schematics for the Eval-M1-099M evaluation board

5.2 Current feedback

Current Feedback Gain—the control on this board has an internal current feedback amplifier which has default gain. The user can use this gain to count the current sensing range and Internal Itrip. An example is shown in Figure 6. The sample resistor is 0.25Ω.

$$R17 = R13 * 1.5, \quad R16 = R13 * 3$$

When input = 0V, IFBO = 601mV

$$\text{Current Feedback Gain} = \frac{R13}{R14} = \frac{7.68K}{5.9K} = 1.302$$

Current sensing range is depending on current sample resistor.

$$\text{Current sensing range} = \frac{0.599}{\text{Current Gain} * \text{Sample resistor}}$$

$$\text{Current sensing range} = \frac{0.599}{1.302 * 0.25\Omega} = 1.84A$$

The part of protect circuit, when using single shunt: Iu current feedback OPAMP internal Itrip can protect overcurrent if the system response designed as demand.

$$\text{Internal Itrip} = \frac{\text{IC maximum specification Itrip level} - 0.601V}{\text{Current Gain} * \text{Sample register}}$$

$$\text{Internal Itrip} = \frac{1.306V - 0.601V}{1.302 * 0.25\Omega} = 2.17A$$

When using leg shunt. The gate kill signal from power module works. That is protected by outside IRMCK099.

When using single shunt. IV+ and IV- connect GND.

Figure 6 depicts the Eval-M1-099M evaluation board is suitable for single shunt and leg shunt for current feedback.

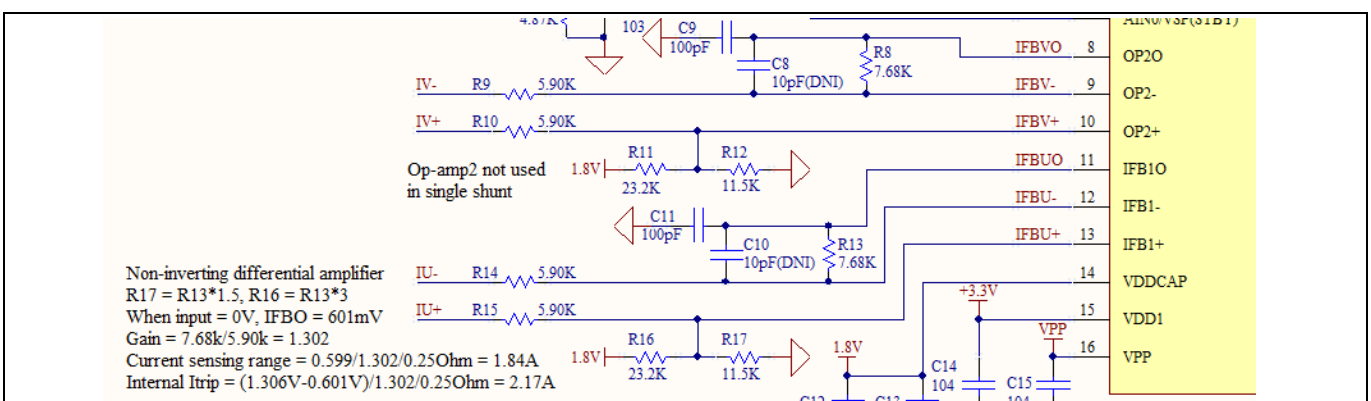

Figure 6 The part of Current feedback on the Eval-M1-099M evaluation board

5.3 AD port Input

Figure 7 depicts AD input for IRMCK099. Temperature input should fit to the design recommendation in the IRMCK099 application note.

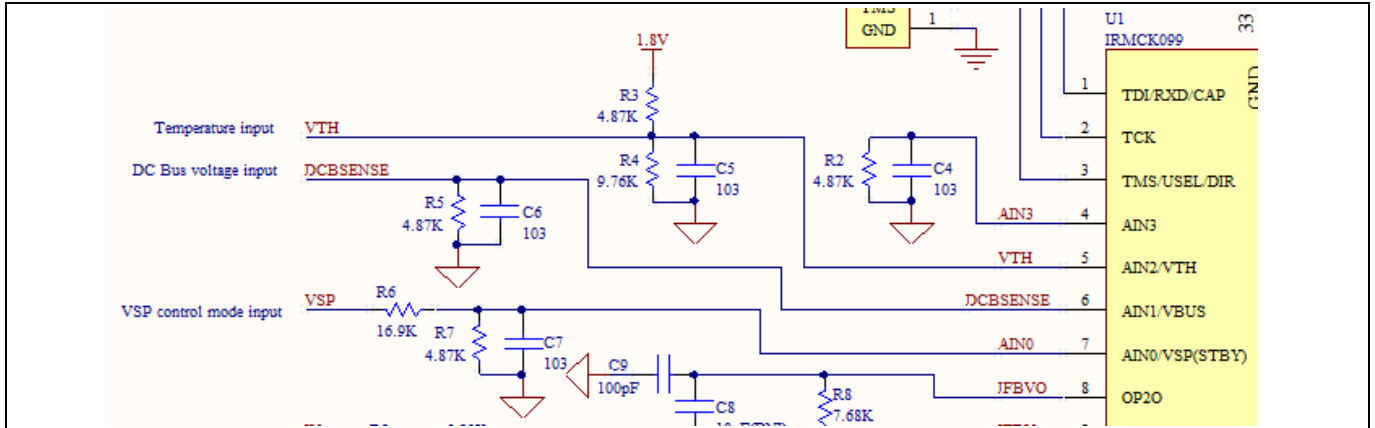

Figure 7 AD input on the Eval-M1-099M evaluation board

Figure 9 depicts the bottom assembly print of the evaluation board.

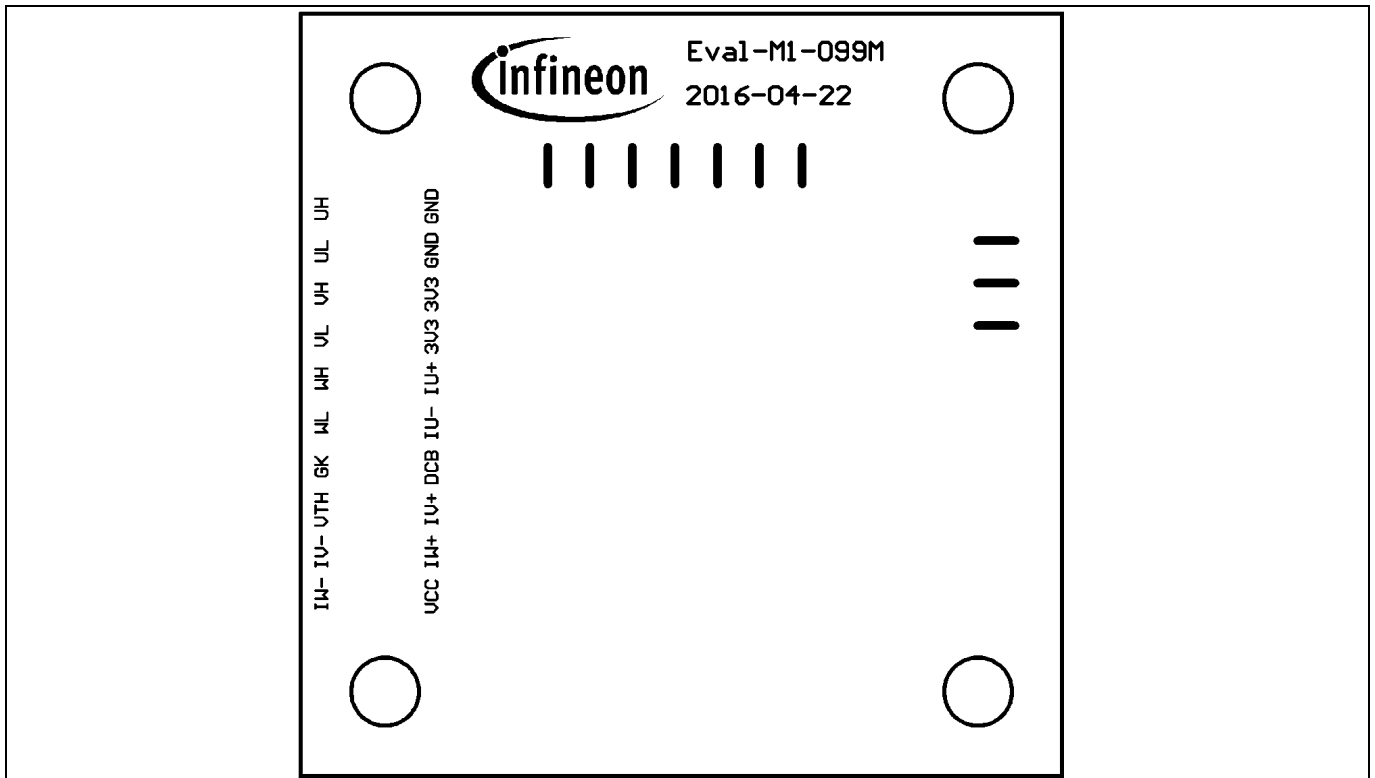

Figure 9 Bottom overlay print of the EVAL-M1-099M evaluation board

The top layer routing of the PCB is provided in the following Figure 10.

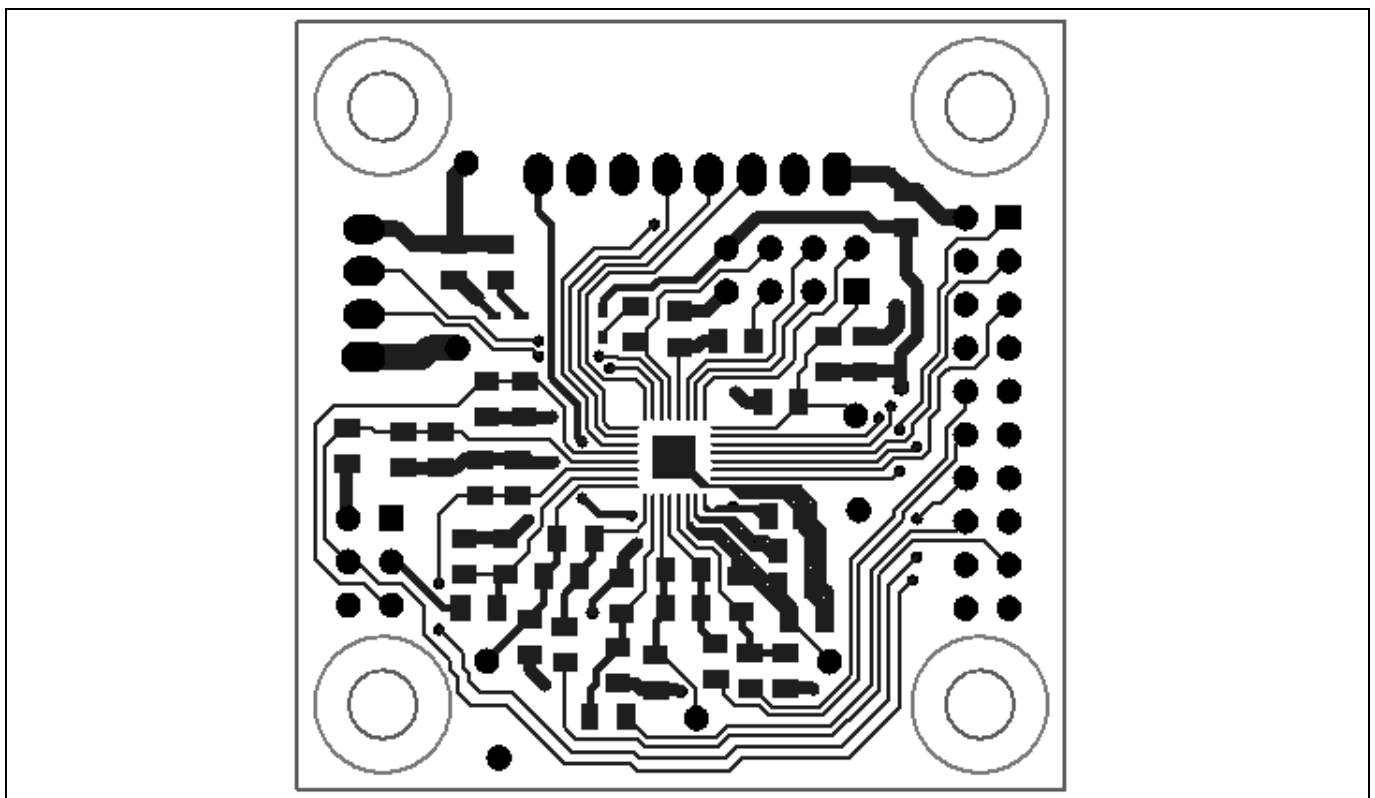

Figure 10 Top layer routing of the EVAL-M1-099M

Figure 11 illustrates the bottom layer routing of the PCB.

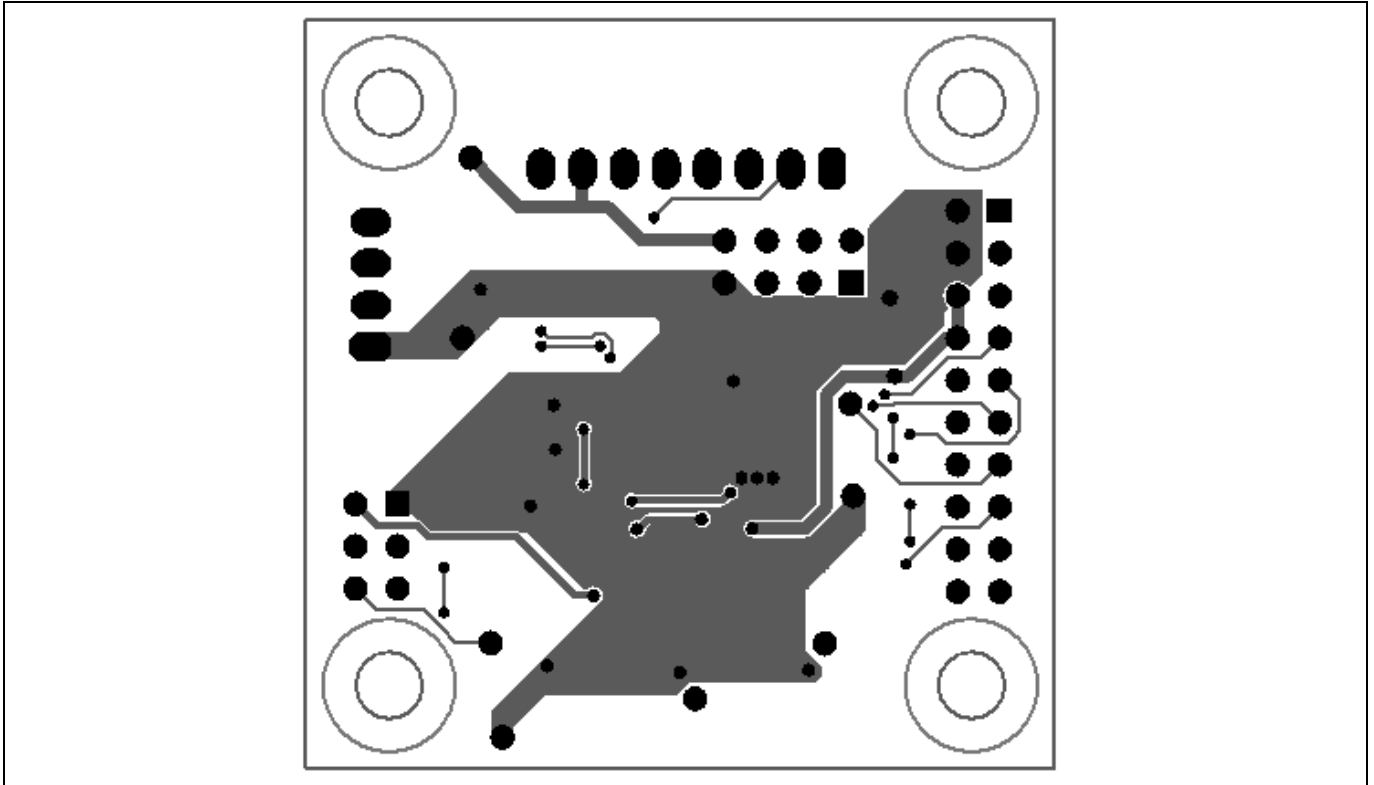

Figure 11 Bottom layer routing of the EVAL-M1-099M

6 Bill of Materials of EVAL-M1-099M

Table 8 provides the complete bill of materials for the EVAL-M1-099M board.

Table 8 Bill of materials

No.	Qty.	Part description	Designator	Part Number	Manufacturer
1	2	CAP CER 10µF 6.3V X7R 0805	C2, C12	CL21B106KQNNNE	Samsung Electro-Mechanics America, Inc.
2	5	CAP CER 0.1µF 50V X7R 0805	C3, C13, C14, C15, C18	08055C104KAT2A	AVX Corporation
3	5	CAP CER 10000pF 50V X7R 0805	C4, C5, C6, C7, C17	C0805C103K5RACTU	Kemet
4	2	CAP CER 10pF 50V NP0 0805	C8, C10	C0805C100J5GACTU	Kemet
5	2	CAP CER 100pF 50V NP0 0805	C9, C11	C0805C101J5GACTU	Kemet
6	1	CAP CER 1000pF 50V X7R 0805	C16	C0805C102K5RACTU	Kemet
7	1	CONN HEADER XH TOP 8POS 2.5mm	J1	B8B-XH-A(LF)(SN)	JST Sales America Inc
8	1	CONN HEADER XH TOP 4POS 2.5mm	J2	B4B-XH-A(LF)(SN)	JST Sales America Inc
9	1	CONN HDR DUAL 20POS .100 R/A TIN	J3	0717640020	Molex,LLC
10	1	CONN HEADER 6POS .100 STR 30AU	J4	67996-106HLF	Amphenol FCI
11	1	CONN HEADER 8POS .100 STR 30AU	J5	67997-108HLF	Amphenol FCI
12	2	LED RED CLEAR 0603 R/A SMD	LED1, LED2	LTST-S270EKT	Lite-On Inc.
13	3	RES SMD 1 kΩ1% 1/8W 0805	R1, R19, R20	RC0805FR-071KL	Yageo
14	5	RES SMD 4.87 kΩ1% 1/8W 0805	R2, R3, R5, R7, R18	RC0805FR-074K87L	Yageo
15	1	RES SMD 9376 kΩ1% 1/8W 0805	R4	RC0805FR-079K76L	Yageo
16	1	RES SMD 16.9 kΩ1% 1/8W 0805	R6	RC0805FR-0716K9L	Yageo
17	2	RES SMD 7.68 kΩ1% 1/8W 0805	R8, R13	RC0805FR-077K68L	Yageo
18	4	RES SMD 5.9 kΩ1% 1/8W 0805	R9, R10, R14, R15	RC0805FR-075K9L	Yageo
19	2	RES SMD 23.2 kΩ1% 1/8W 0805	R11, R16	RC0805FR-0723K2L	Yageo
20	2	RES SMD 11.5 kΩ1% 1/8W 0805	R12, R17	RC0805FR-0711K5L	Yageo
21	1	TEST POINT PC MINI .040"D WHITE	TP1	5002	Keystone Electronics
22	1	TEST POINT PC MINI .040"D WHITE	TP2	5002	Keystone Electronics
23	1	TEST POINT PC MINI .040"D WHITE	TP3	5002	Keystone Electronics
24	2	TEST POINT PC MINI .040"D	TP4, TP5	5002	Keystone Electronics

Bill of Materials of EVAL-M1-099M

No.	Qty.	Part description	Designator	Part Number	Manufacturer
		WHITE			
25	1	TEST POINT PC MINI .040"D WHITE	TP8	5002	Keystone Electronics
26	1	TEST POINT PC MINI .040"D WHITE	TP9	5002	Keystone Electronics
27	1	TEST POINT PC MINI .040"D WHITE	TP10	5002	Keystone Electronics
28	1	IRMCK099	U1	Control IC	Infineon Technologies

7 Reference

[1] Datasheet of Infineon IRMCK099M

[2] IRMCx100 Reference Manual

[3] IRMCx100 Software Developer's Guide

[4] IRMCx100 System Overview

[5] Application Note of AN2016-24 for EVAL-M1-05-65D power board, is available for download on Infineon's website

[6] MCETOOLV2 user manual, is available on Infineon website.

Note1: Above all reference materials are available for download on Infineon's website www.infineon.com

Revision History

Major changes since the last revision

Version number	Revision Date	Revision description
1.0	2017-08-21	First release

Trademarks of Infineon Technologies AG

AURIX™, C166™, CanPAK™, CIPOS™, CoolGaN™, CoolMOS™, CoolSET™, CoolSiC™, CORECONTROL™, CROSSAVE™, DAVE™, DI-POL™, DrBlade™, EasyPIM™, EconoBRIDGE™, EconoDUAL™, EconoPACK™, EconoPIM™, EiceDRIVER™, eupec™, FCOS™, HITFET™, HybridPACK™, Infineon™, ISOFACE™, IsoPACK™, i-Wafer™, MIPAQ™, ModSTACK™, my-d™, NovalithIC™, OmniTune™, OPTIGA™, OptiMOS™, ORIGA™, POWERCODE™, PRIMARION™, PrimePACK™, PrimeSTACK™, PROFET™, PRO-SIL™, RASIC™, REAL3™, ReverSave™, SatRIC™, SIEGET™, SIPMOS™, SmartLEWIS™, SOLID FLASH™, SPOC™, TEMPFET™, thinQ!™, TRENCHSTOP™, TriCore™.

Trademarks updated August 2015

Other Trademarks

All referenced product or service names and trademarks are the property of their respective owners.

Edition <2017-08-21>

Published by

Infineon Technologies AG
81726 Munich, Germany

© 2017 Infineon Technologies AG.
All Rights Reserved.

Do you have a question about this document?

Email: erratum@infineon.com

AN2017-18 EVAL-M1-099M-C User
Document reference
Manual

IMPORTANT NOTICE

The information contained in this application note is given as a hint for the implementation of the product only and shall in no event be regarded as a description or warranty of a certain functionality, condition or quality of the product. Before implementation of the product, the recipient of this application note must verify any function and other technical information given herein in the real application. Infineon Technologies hereby disclaims any and all warranties and liabilities of any kind (including without limitation warranties of non-infringement of intellectual property rights of any third party) with respect to any and all information given in this application note.

The data contained in this document is exclusively intended for technically trained staff. It is the responsibility of customer's technical departments to evaluate the suitability of the product for the intended application and the completeness of the product information given in this document with respect to such application.

For further information on the product, technology, delivery terms and conditions and prices please contact your nearest Infineon Technologies office (www.infineon.com).

Please note that this product is not qualified according to the AEC Q100 or AEC Q101 documents of the Automotive Electronics Council.

WARNINGS

Due to technical requirements products may contain dangerous substances. For information on the types in question please contact your nearest Infineon Technologies office.

Except as otherwise explicitly approved by Infineon Technologies in a written document signed by authorized representatives of Infineon Technologies, Infineon Technologies' products may not be used in any applications where a failure of the product or any consequences of the use thereof can reasonably be expected to result in personal injury.