

Eval-M1-CM610N3

iMOTION™ Modular Application Design Kit

About this document

Scope and purpose

This application note provides an overview of the evaluation board Eval-M1-CM610N3 including its main features, key data, pin assignments and mechanical dimensions.

Eval-M1-CM610N3 is a complete evaluation board including a 3-phase CIPOS™ Mini Intelligent Power Module (IPM) for motor drive application. In combination with control-boards equipped with the M1 20pin interface connector, like EVAL-M1-1302 or EVAL-M1-099M, it features and demonstrates Infineon's CIPOS™ Mini IPM technology for motor drive.

The evaluation board Eval-M1-CM610N3 was developed to support customers during their first steps designing applications with CIPOS™ Mini IPM.

CIPOS™ Mini IPM in this board is IKCM10H60GA which has 600V of voltage and 10A of current rating. It is optimized to high frequency switching application like washing machine, fan, etc.

Intended audience

This application note is intended for all technical specialists working with the Eval-M1-CM610N3 board.









Table of Contents

About this document.....	1
Table of Contents	1
1 Safety precautions.....	2
2 Introduction.....	3
3 Main features	5
4 Pin assignments	8
5 Schematics and Layout.....	10
5.1 DC-Link Voltage Measurement	10
5.2 EMI filter and soft power up circuit.....	10
5.3 Inverter section using CIPOS™ mini IPM.....	11
5.4 Auxiliary power supply	12
5.5 Overcurrent protection circuit.....	12
5.6 Thermistor Output	13
5.7 Overtemperature Hardware Protection Circuit	14
5.7.1 Power-on and power-off VDD under voltage test waveforms.....	14
5.7.2 Overcurrent protection test waveform	15
5.7.3 Overtemperature protection test waveform	16
5.8 PCB Layout	17
6 Bill of Materials of Eval-M1-CM610N3	21
7 Reference	24
Revision History	25

1 Safety precautions

In addition to the precautions listed throughout this manual, please read and understand the following statements regarding hazards associated with development systems.

Table 1 **Precautions**

	<p>Attention: <i>The ground potential of the Eval-M1-CM610N3 system is biased to a negative DC bus voltage potential. When measuring voltage waveform by oscilloscope, the scope's ground needs to be isolated. Failure to do so may result in personal injury or death. Darkened display LEDs are not an indication that capacitors have discharged to safe voltage levels.</i></p>
	<p>Attention: <i>Eval-M1-CM610N3 system contains DC bus capacitors which take time to discharge after removal of the main supply. Before working on the drive system, wait three minutes for capacitors to discharge to safe voltage levels. Failure to do so may result in personal injury or death. Darkened display LEDs are not an indication that capacitors have discharged to safe voltage levels.</i></p>
	<p>Attention: <i>Only personnel familiar with the drive and associated machinery should plan or implement the installation, start-up and subsequent maintenance of the system. Failure to comply may result in personal injury and/or equipment damage.</i></p>
	<p>Attention: <i>The surfaces of the drive may become hot, which may cause injury.</i></p>
	<p>Attention: <i>Eval-M1-CM610N3 system contains parts and assemblies sensitive to Electrostatic Discharge (ESD). Electrostatic control precautions are required when installing, testing, servicing or repairing this assembly. Component damage may result if ESD control procedures are not followed. If you are not familiar with electrostatic control procedures, refer to applicable ESD protection handbooks and guidelines.</i></p>
	<p>Attention: <i>A drive, incorrectly applied or installed, can result in component damage or reduction in product lifetime. Wiring or application errors such as under sizing the motor, supplying an incorrect or inadequate AC supply or excessive ambient temperatures may result in system malfunction.</i></p>
	<p>Attention: <i>Remove and lock out power from the drive before you disconnect or reconnect wires or perform service. Wait three minutes after removing power to discharge the bus capacitors. Do not attempt to service the drive until the bus capacitors have discharged to zero. Failure to do so may result in personal injury or death.</i></p>
	<p>Attention: <i>Eval-M1-CM610N3 system is shipped with packing materials that need to be removed prior to installation. Failure to remove all packing materials which are unnecessary for system installation may result in overheating or abnormal operating condition.</i></p>

Introduction

2 Introduction

The Eval-M1-CM610N3 evaluation board is a part of the iMOTION™ Modular Application Design Kit for drives (iMOTION™ MADK).

The MADK platform is intended to use various power stages with different control boards. These boards can easily be interfaced through the iMOTION™ MADK-M1 20 pin interface connector.

This evaluation board is designed to give Easy-to-use power stage based on the Infineon's CIPOS™ Mini Intelligent Power Module (IPM). The board is equipped with all assembly groups for sensorless field oriented control (FOC). It provides a single-phase AC-connector, rectifier and 3-phase output for for connecting the motor. The power stage also contains emitter shunts for current sensing and a voltage divider for DC-link voltage measurement.

The Eval-M1-CM610N3 evaluation board is available through regular Infineon distribution partners as well as on Infineon's website. The features of this board are described in the design feature chapter of this document, whereas the remaining paragraphs provide information to enable the customers to copy, modify and qualify the design for production according to their own specific requirements.

Environmental conditions were considered in the design of the Eval-M1-CM610N3. The design was tested as described in this document but not qualified regarding safety requirements or manufacturing and operation over the whole operating temperature range or lifetime. The boards provided by Infineon are subject to functional testing only.

Evaluation boards are not subject to the same procedures as regular products regarding Returned Material Analysis (RMA), Process Change Notification (PCN) and Product Discontinuation (PD). Evaluation boards are intended to be used under laboratory conditions and by trained specialists only.

The block diagram of the Eval-M1-CM610N3 is depicted in Figure 1. This evaluation board includes an EMI filter and soft power up circuit, 20 pin iMOTION™ MADK-M1 interface connector, auxiliary power supply to provide 15V and 3.3V, and the CIPOST™ Mini IPM IKCM10H60GA.

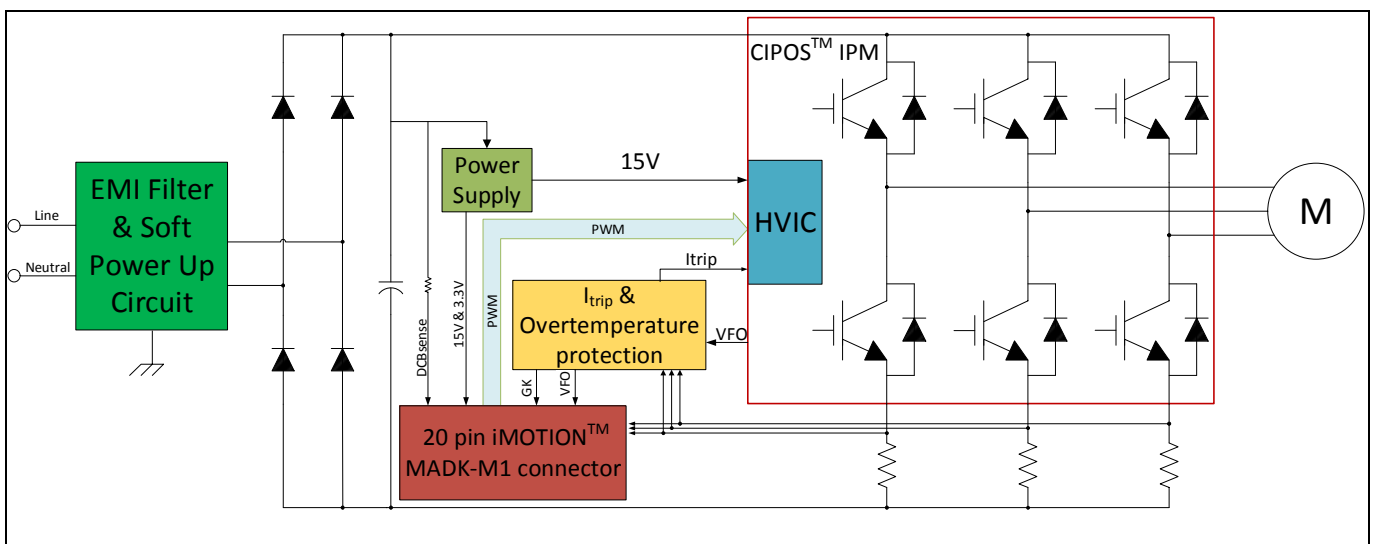

Figure 1 The Block Diagram of the Eval-M1-CM610N3

CIPOS™ Mini IPM in this board is IKCM10H60GA which has 600V of voltage and 10A of current rating. It is optimized to high frequency switching application like washing machine, fan, etc.

Introduction

The hardware circuit protecting the design regarding overtemperature and overcurrent is also included in this power board. The sense connections to all three shunt resistors are connected to the 20 pin iMOTION™ MADK-M1 interface connector. This power board is compatible with all CIPOS™ Mini IPMs that feature open emitter and built-in NTC considering motor power rating and IPM's current rating.

Main features

3 Main features

Eval-M1-CM610N3 is an evaluation board for motor drive applications based on a 3-phase IPM. Combined in a kit with one of the available MADK control board options, it demonstrates Infineon's IPM technology for motor drives. The kit demonstrates Infineon's IPM technology for motor drives.

Main features of CIPOS™ Mini IPM IKCM10H60GA are:

- TRENCHSTOP™ IGBTs
- Maximum blocking voltage $V_{CES} = 600V$
- Maximum output current at 25°C case temperature $I_c = 10A$
- Fully isolated Dual In-Line molded module
- Rugged SOI gate driver technology with stability against transient and negative voltages
- Negative potential allowed up to $V_s = -11V$ for signal transmission at $V_{BS} = 15V$
- Integrated bootstrap functionality
- Overcurrent shutdown
- Temperature monitoring
- Undervoltage lockout at all channels
- Low side emitter pins accessible for phase current monitoring in open emitter configuration
- Cross conduction prevention
- All six switches turn off during protection
- Lead-free terminal plating; RoHS compliant

The evaluation board characteristics are:

- Nominal input voltage 220 V_{AC}
- Maximum 750 W motor power output
- On board EMI filter
- Current sensing for each phase configured by default
- Overcurrent protection
- Overtemperature hardware protection
- Sensing of DC-link voltage
- Thermistor output
- Fault diagnostic output
- Measurement test-points compatible to standard oscilloscope probes
- PCB is 120 mm x 120 mm and has two layers with 35 μm copper each
- RoHS complaint

Main features

Table 2 depicts the important specifications of the evaluation board Eval-M1-CM610N3.

Table 2 Eval-M1-CM610N3 board specifications

Parameters	Values	Conditions / comments
Input		
Voltage	110 - 240 V _{rms}	lower AC input, less motor power output
Input current	5.1 A _{rms}	input 240 V _{AC} , T _a =25°C, IKCM10H60GA
Output		
Power (3phases)	750 W	input 240V _{AC} , f _{PWM} =10 kHz, T _a =25°C, T _h =80°C
Current per leg	2.7 A _{rms}	input 240V _{AC} , f _{PWM} =10 kHz, T _a =25°C, T _h =80°C
DC Bus Voltage		
Maximum DC bus voltage	380 V	
Minimum DC bus voltage	120 V	
Current feedback		
Current sensing resistors RS1, RS2, RS3	100 mΩ	The default configuration uses three shunts in the emitter paths. To implement single shunt sensing, R37 and R38 have to be assembled with 0 Ω resistors; R21 has to be changed to 2.2 kΩ
Protections		
Output current trip level	7.0 A _{peak}	Configured by either changing shunt resistors RS1, RS2, RS3 or adapting comparator threshold divider resistor R21
Temperature trip level	100 °C	Only valid for CIPOS™ with built in NTC
On board power supply		
15 V	15 V ± 5 %, max. 50 mA	Used for CIPOS™ IPM gate driver and LDO
3.3 V	3.3 V ± 2 %, max. 20 mA	Supplying the 3.3V to the controller board and protection circuits
PCB characteristics		
Material	FR4, 1.6 mm thickness, 2 layers. 35 μm copper thickness	
Dimension	120 mm x 120 mm	
System environment		
Ambient temperature	From 0 to 50°C	Non-condensing, maximum RH of 95 %

Eval-M1-CM610N3

iMOTION™ Modular Application Design Kit

Main features

Figure 2 points out the functional groups on the top side of the Eval-M1-CM610N3 evaluation board.

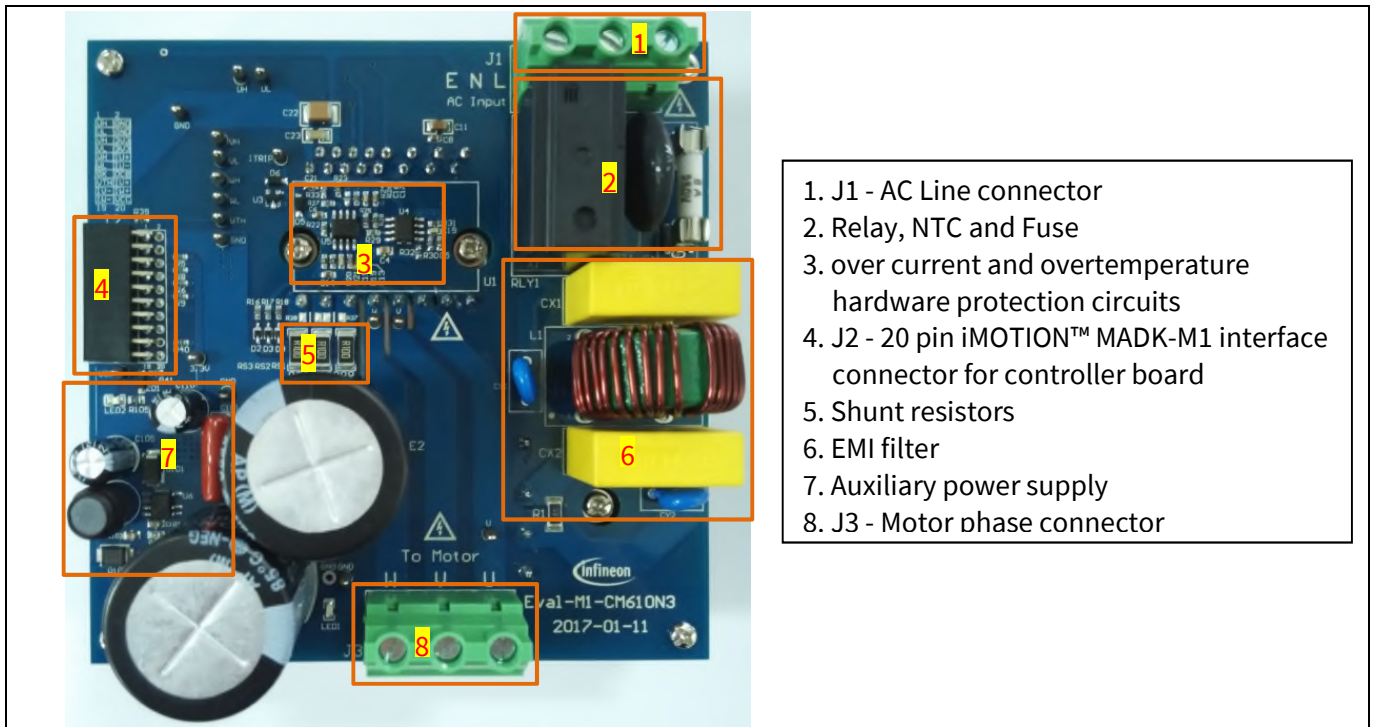

1. J1 - AC Line connector
2. Relay, NTC and Fuse
3. over current and overtemperature hardware protection circuits
4. J2 - 20 pin iMOTION™ MADK-M1 interface connector for controller board
5. Shunt resistors
6. EMI filter
7. Auxiliary power supply
8. J3 - Motor phase connector

Figure 2 Functional groups of the Eval-M1-CM610N3 evaluation board's top side

Figure 3 points out the functional groups on the bottom side of the Eval-M1-CM610N3 evaluation board.

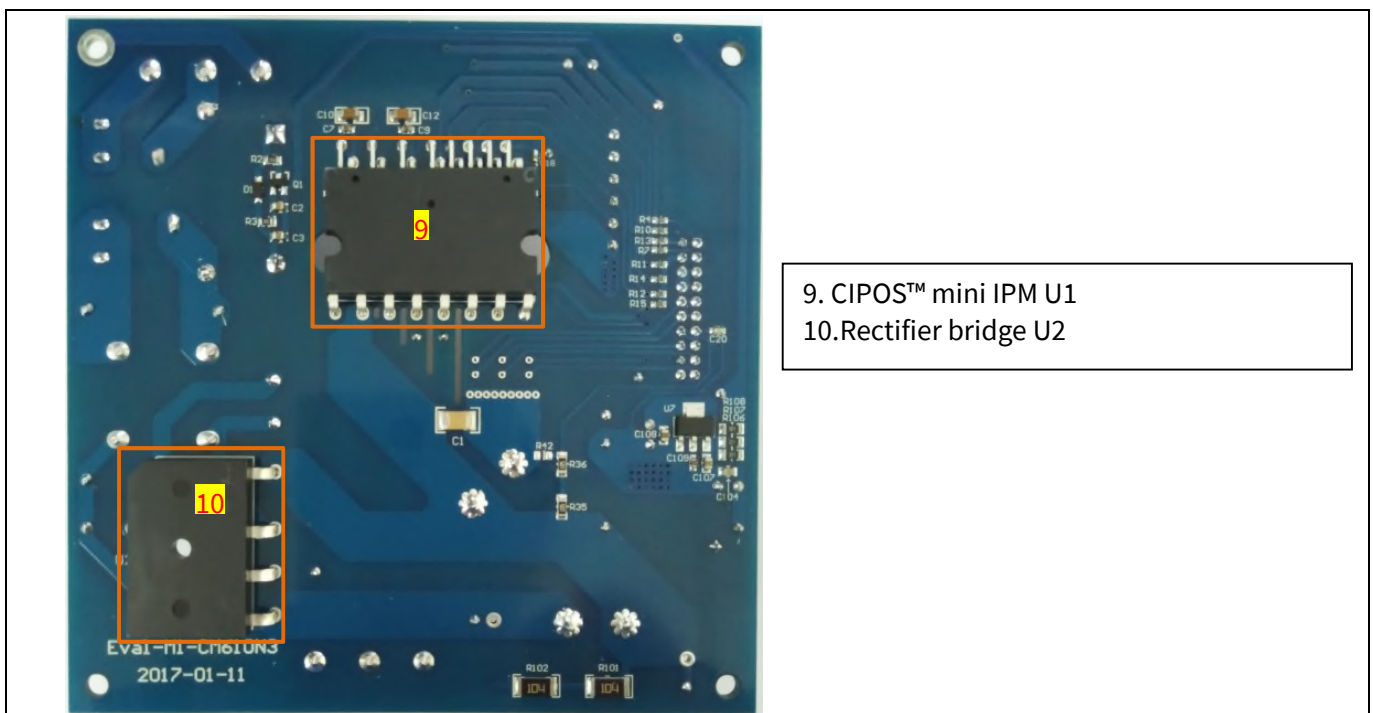

9. CIPOST™ mini IPM U1
10. Rectifier bridge U2

Figure 3 Functional groups of the Eval-M1-CM610N3 evaluation board's bottom side

4 Pin assignments

General information about the connectors of the Eval-M1-CM610N3 evaluation board is reported. Table 3 includes the details of the AC line connector J1.

Table 3 J1- AC Line connector

S. No.	Pin	Details
1	EARTH	Earth ground
2	N	AC neutral input
3	L	AC line input (110 V – 240 V)

Table 4 provides the pin assignments of the 20 pin iMOTION™ MADK-M1 interface connector J2. This connector is the interface to the controller board.

Table 4 J2 - iMOTION™ MADK-M1 20 pin interface connector for controller board

Pin	Name	Pin Name Connectors
1	PWMUH	3.3 V compatible logic input for high side gate driver-Phase U
2	GND	Ground
3	PWMUL	3.3 V compatible logic input for low side gate driver-Phase U
4	GND	4 GND Ground
5	PWMVH	3.3 V compatible logic input for high side gate driver-Phase V
6	+3.3V	On board 3.3 V supply
7	PWMVL	3.3 V compatible logic input for low side gate driver-Phase V
8	+3.3V	On board 3.3 V supply
9	PWMWH	3.3 V compatible logic input for high side gate driver-Phase W
10	I_U	Shunt voltage phase U
11	PWMWL	3.3 V compatible logic input for low side gate driver-Phase W
12	I_U-	Ground
13	GK	Gate kill signal – active low when overcurrent is detected
14	DCBSENSE	DC bus positive voltage, scaled in 0-3.3 V range by a voltage divider
15	VTH	Thermistor Output
16	I_V	Shunt voltage phase V
17	I_V-	Ground
18	I_W	Shunt voltage phase W
19	I_W-	Ground
20	VCC	15 V Power Supply

Pin assignments

Table 5 denotes the details of the motor side connector J3.

Table 5 J3- Motor side connector

S. No.	Pin	Details
1	U	Connected to motor phase U
2	V	Connected to motor phase V
3	W	Connected to motor phase W

5 Schematics and Layout

To meet individual customer requirements and make the Eval-M1-CM610N3 evaluation board a basis for development or modification, all necessary technical data like schematics, layout and components are included in this chapter.

5.1 DC-Link Voltage Measurement

Pin 14 of connector J2 provides access to the DC-link voltage. Three possible feedback cases are associated with this pin. Figure 4 provides the DC bus sense resistor details. By default, the resistor R42 is not mounted on Eval-M1-CM610N3. There must be a pull-down resistor mounted on the corresponding controller board.

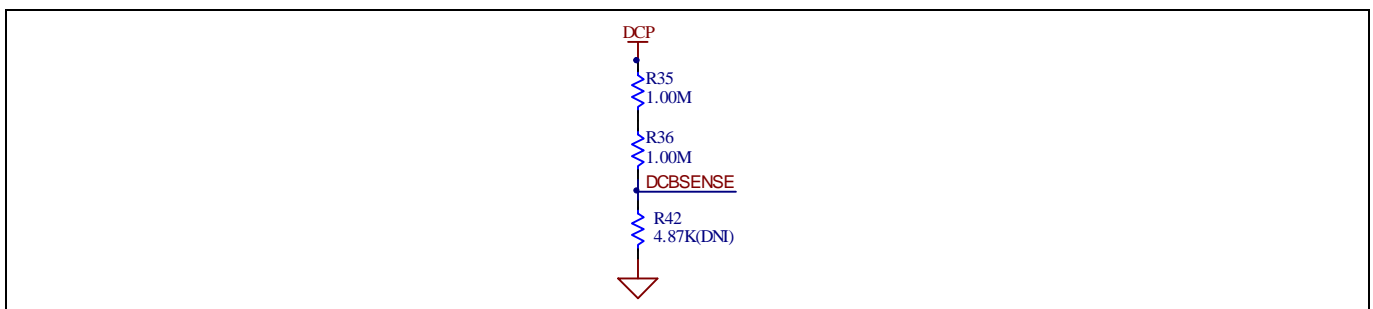

Figure 4 DC bus sense resistor on Eval-M1-CM610N3 evaluation board

If a pull down resistor of 4.87 kΩ referred to ground is inserted either on the Eval-M1-CM610N3 evaluation board or on the control board, the DCBSENSE voltage results in the range of 0 to 3.3 V on the pin reflecting a DC bus voltage range of 0 to 400 V.

If a pull down resistor of 4.87 kΩ is inserted on both, Eval-M1-CM610N3 evaluation board and on the control card, the DCBSENSE results scale to 0-1.65 V. No safety issue occurs. If no feedback is desired on the DCBSENSE pin, R35 or R36 should be removed to avoid high voltage on the connector.

5.2 EMI filter and soft power up circuit

Figure 5 depicts the schematic from the AC line input connector J1 to the rectified DC bus voltage. This circuitry includes a passive EMI filter consisting of elements CX1, CX2, L1, CY1 and CY2, a 25 A/600 V rectifier block U2, a fuse F1 for inrush current protection, a NTC resistor RT1 and a relay RLY1 for soft powering up and reducing conduction losses in steady state. Two electrolytic capacitors E1 and E2 are used for buffering the rectified DC bus voltage DCP.

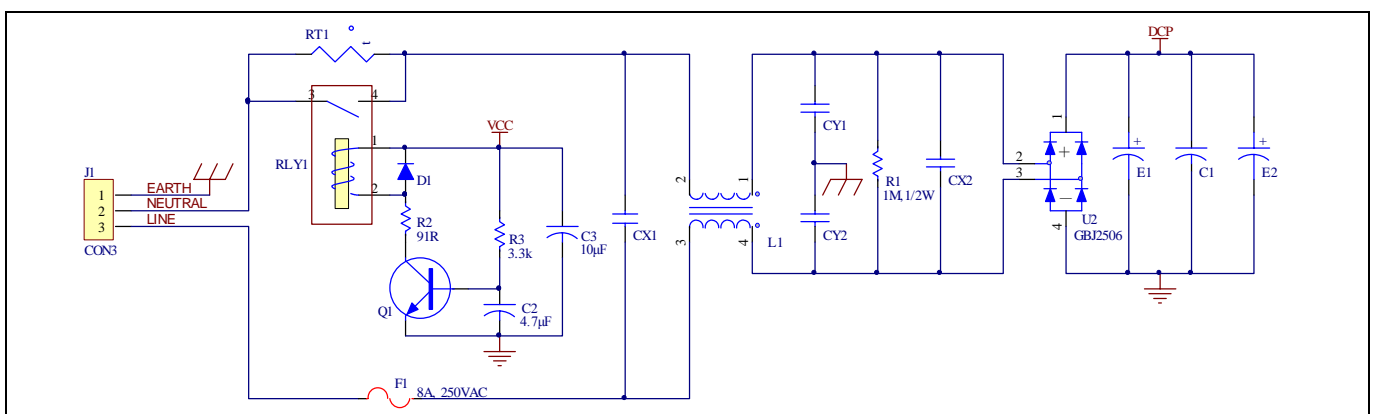

Figure 5 Schematic for EMI filter and AC/DC section of the Eval-M1-CM610N3 evaluation board

5.3 Inverter section using CIPOS™ mini IPM

The inverter section is implemented using the CIPOS™ mini IPM as sketched in Figure 6. The module includes an optimized SOI gate driver and a three-phase inverter consisting of TRENCHSTOP™ IGBTs and anti parallel diodes.

The three capacitors C10, C11 and C12 are used as bootstrap capacitors to provide the necessary floating supply voltages V_{BS1} , V_{BS2} and V_{BS3} respectively.

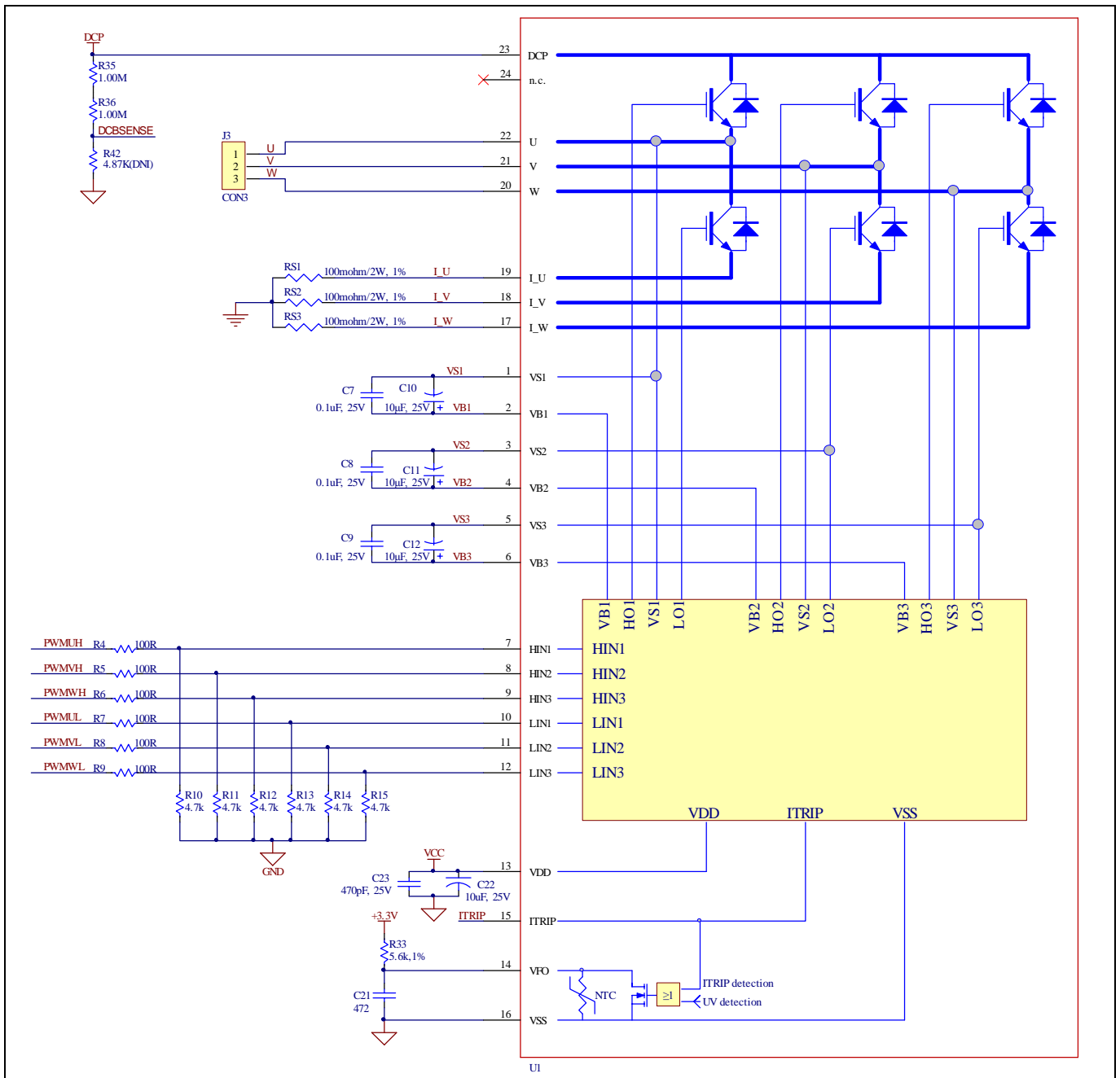

Figure 6 Schematic of the 3-phase inverter section using CIPOS™ mini IPM on Eval-M1-CM610N3

5.4 Auxiliary power supply

Figure 7 depicts the schematic of the auxiliary power supply available on the Eval-M1-CM610N3 board. The circuit includes a LNK304 that is used to generate 15 V directly from the DC bus. V_{CC} is connected to the gate drivers inside the CIPOS™ IPM.

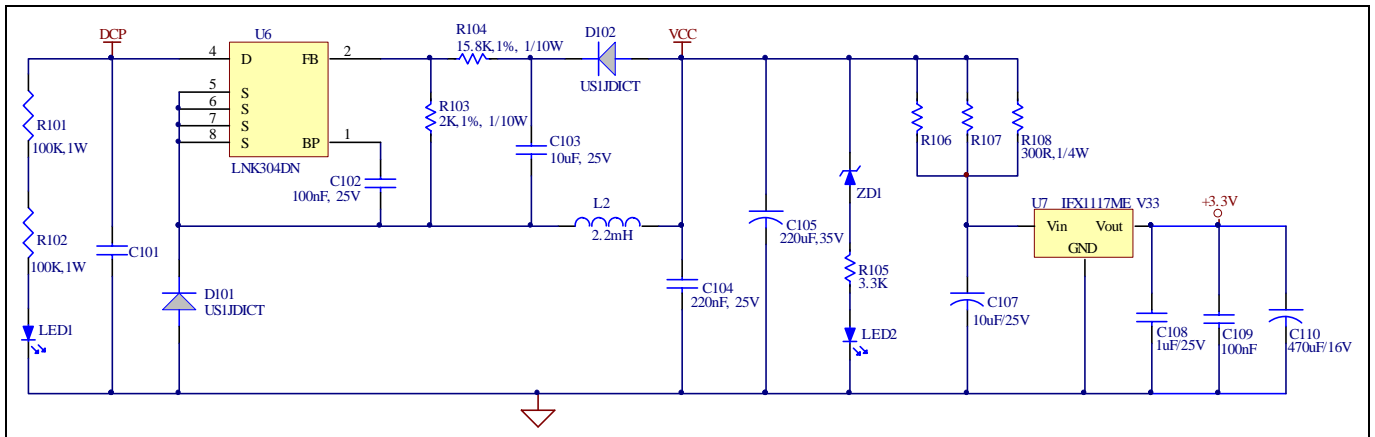

Figure 7 Power supply section of the Eval-M1-CM610N3 evaluation board

The linear voltage regulator IFX1117ME V33 generates 3.3 V from 15 V power supply V_{CC}. The 3.3 V power supply is used in the overcurrent comparator circuit and overtemperature hardware protection circuit. Both V_{CC} and 3.3 V are also present on the 20 pin interface connector J2 to power circuitry on the controller board.

5.5 Overcurrent protection circuit

Figure 8 displays the overcurrent protection circuitry. The open collector output of the comparator U5A is pulled up to 3.3 V by resistor R22 and ITRIP is filtered through capacitor C18.

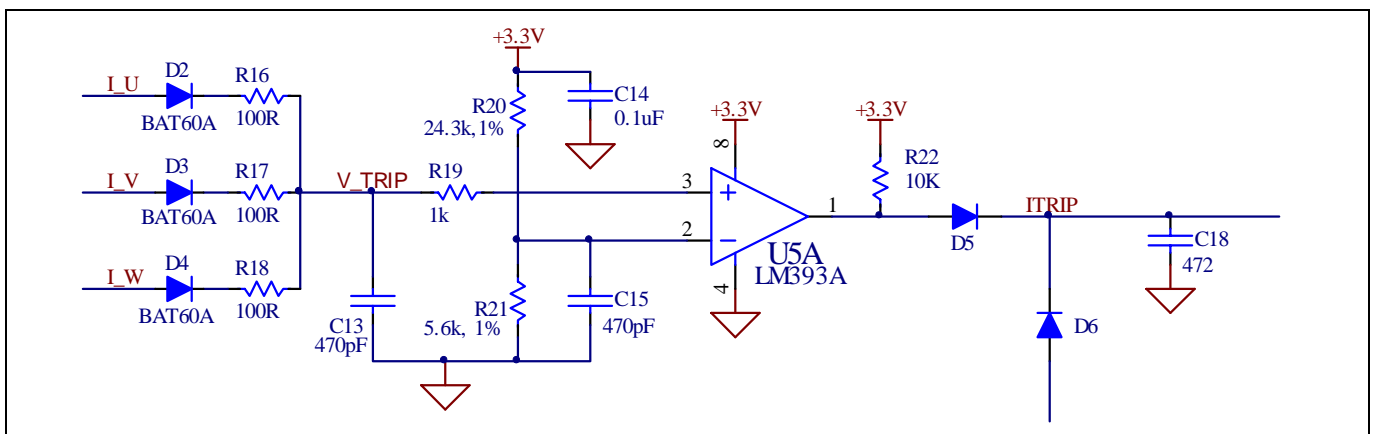

Figure 8 Overcurrent protection circuit on the Eval-M1-CM610N3 evaluation board

The comparator threshold can be set through the voltage divider provided by resistors R20 and R21. By default for emitter shunt trip, R21 is 5.6kΩ. For higher current trip level, R21 needs to be changed to larger resistance.

5.6 Thermistor Output

This board provides Thermistor/NTC output on pin 15 of the 20 pin connector J2. Temperatures can be calculated by resistor measurement. The thermistor characteristics for CIPOS™ mini IPM with build in NTC are listed as summarized in Table 6.

Table 6 CIPOS™ Internal NTC – Thermistor Characteristics

Description	Condition	Symbol	Value			Unit
			min	typ	max	
Resistor	T _{NTC} = 25°C	R _{NTC}	79.638	85.000	90.362	kΩ
Resistor	T _{NTC} = 50°C	R _{NTC}	28.400	29.972	31.545	kΩ
Resistor	T _{NTC} = 60°C	R _{NTC}	19.517	20.515	21.514	kΩ
Resistor	T _{NTC} = 70°C	R _{NTC}	13.670	14.315	14.960	kΩ
Resistor	T _{NTC} = 80°C	R _{NTC}	9.745	10.169	10.593	kΩ
Resistor	T _{NTC} = 90°C	R _{NTC}	7.062	7.345	7.628	kΩ
Resistor	T _{NTC} = 100°C	R _{NTC}	5.199	5.388	5.576	kΩ
Resistor	T _{NTC} = 110°C	R _{NTC}	3.856	4.009	4.163	kΩ
Resistor	T _{NTC} = 120°C	R _{NTC}	2.900	3.024	3.149	kΩ
Resistor	T _{NTC} = 125°C	R _{NTC}	2.527	2.639	2.751	kΩ
B-constant of NTC		B(25/100)		4092		K

The VFO pin of CIPOS™-Modules provides direct access to the NTC, which is referenced to VSS. An external pull-up resistor connected to +3.3V ensures that the resulting voltage can be directly connected to the microcontroller.

Figure 9 depicts the CIPOS™ internal circuit at pin VFO. An external pull-up resistor is required to bias the NTC.

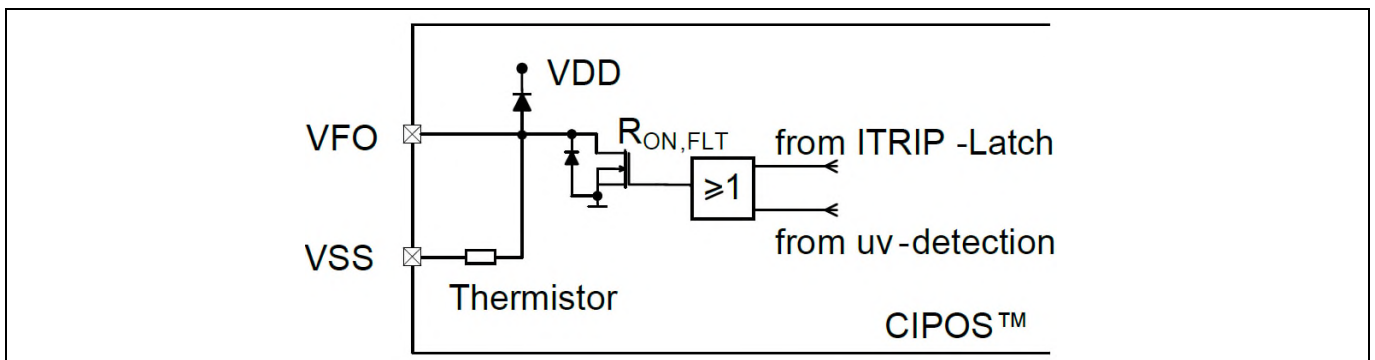

Figure 9 Internal circuit at pin VFO for CIPOS™ IPM IKCM10H60GA

5.7 Overtemperature Hardware Protection Circuit

The VFO pin not only provides direct access to the NTC, but also indicates a module failure in case of under voltage at pin VDD or in case of triggered overcurrent detection at ITRIP. If the overtemperature hardware protection circuit is needed, the resulting voltage of VFO can be compared to a comparator threshold which can be set through the voltage divider provided by resistors R25 and R26 in Figure 10. When the output ov_temp of the comparator U5B is connected to ITRIP, an additional circuit denoted by the dashed box in Figure 10 is needed to prevent an endless loop between ITRIP and VFO.

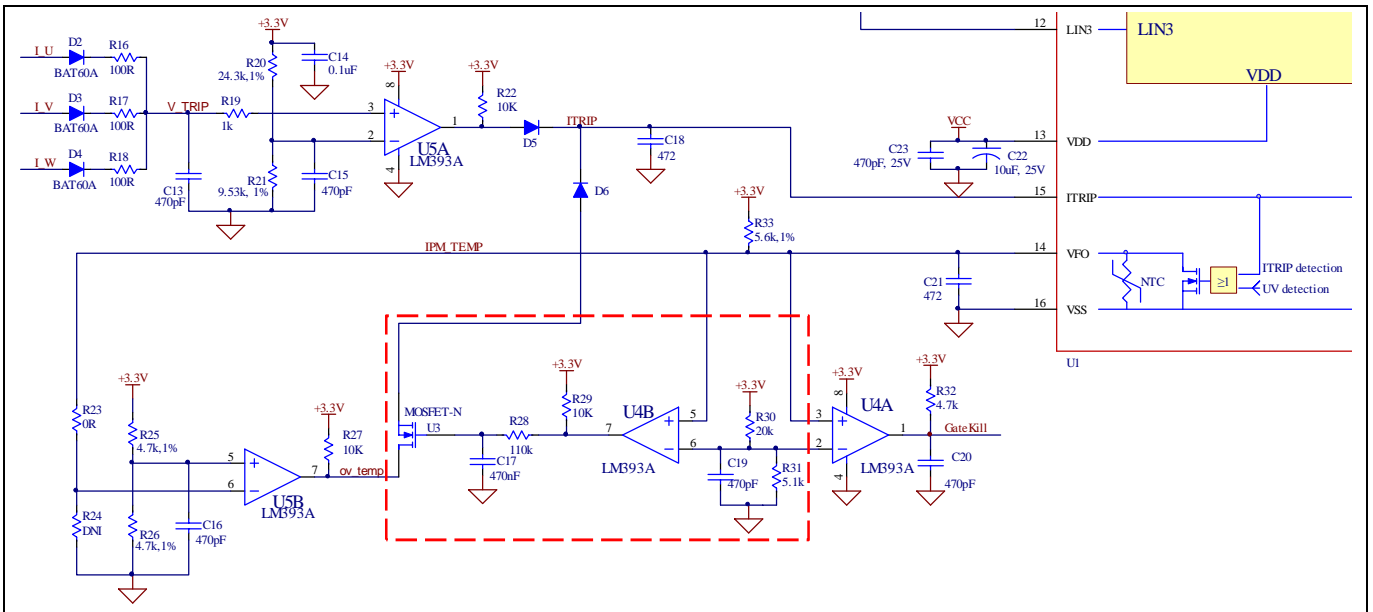

Figure 10 Overcurrent and overtemperature protection circuit schematic for Eval-M1-CM610N3

5.7.1 Power-on and power-off VDD under voltage test waveforms

Power-on test waveform at pin VDD of CIPOS™ IPM going from 0 to 15 V is displayed in Figure 11.

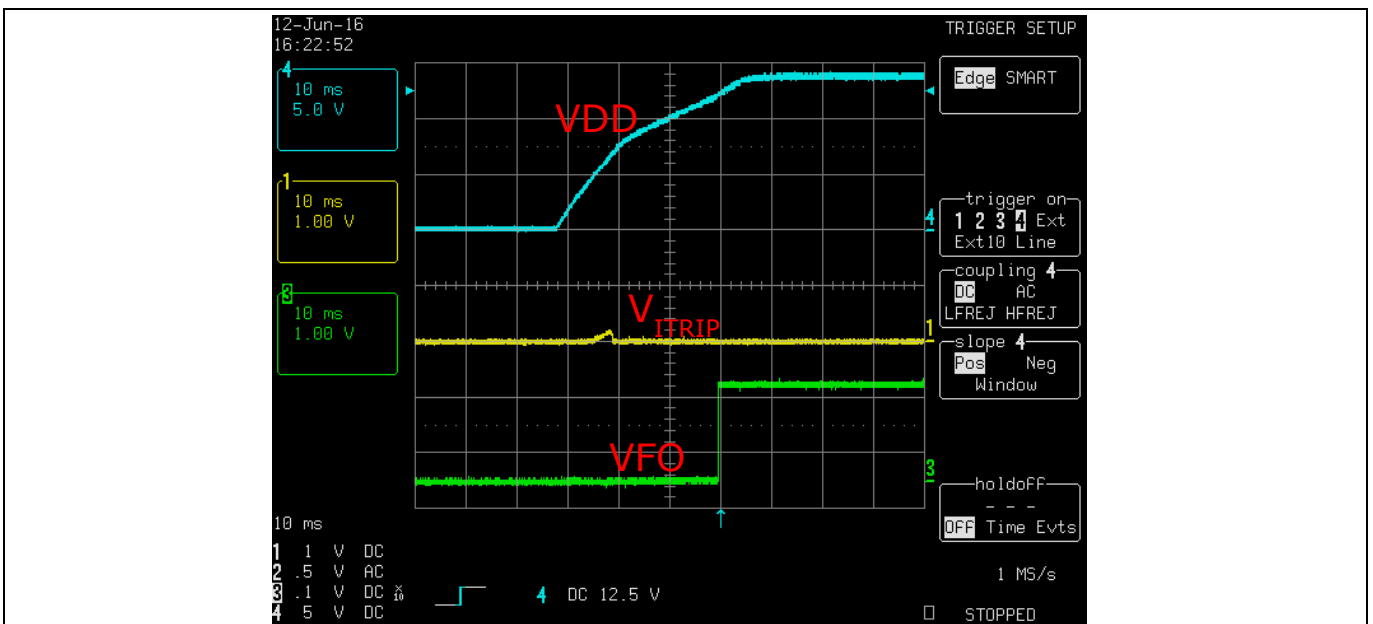

Figure 11 Power-on test waveform at pins VDD , ITRIP and VFO of CIPOS™ IPM

After powering up this power board, VDD is increasing from 0 to 15 V. When VDD is lower than the under voltage positive going threshold V_{DDUV+} , the output of VFO is pulled down to 0V by the gate drive IC inside the CIPOS™ mini IPM. Then the NMOS U3 will be turned off to avoid an endless loop. Both VFO and V_{ITRIP} are pulled down to 0V. While VDD is higher than V_{DDUV+} , VFO will be pulled up to high. The output of U5B is kept 0, although U3 is turning on the output of U5B to D6. There is no change for V_{ITRIP} when VDD changes from 0 to 15 V.

Power-off test waveform at pin VDD going from 15 V to 0 is provided in Figure 12.

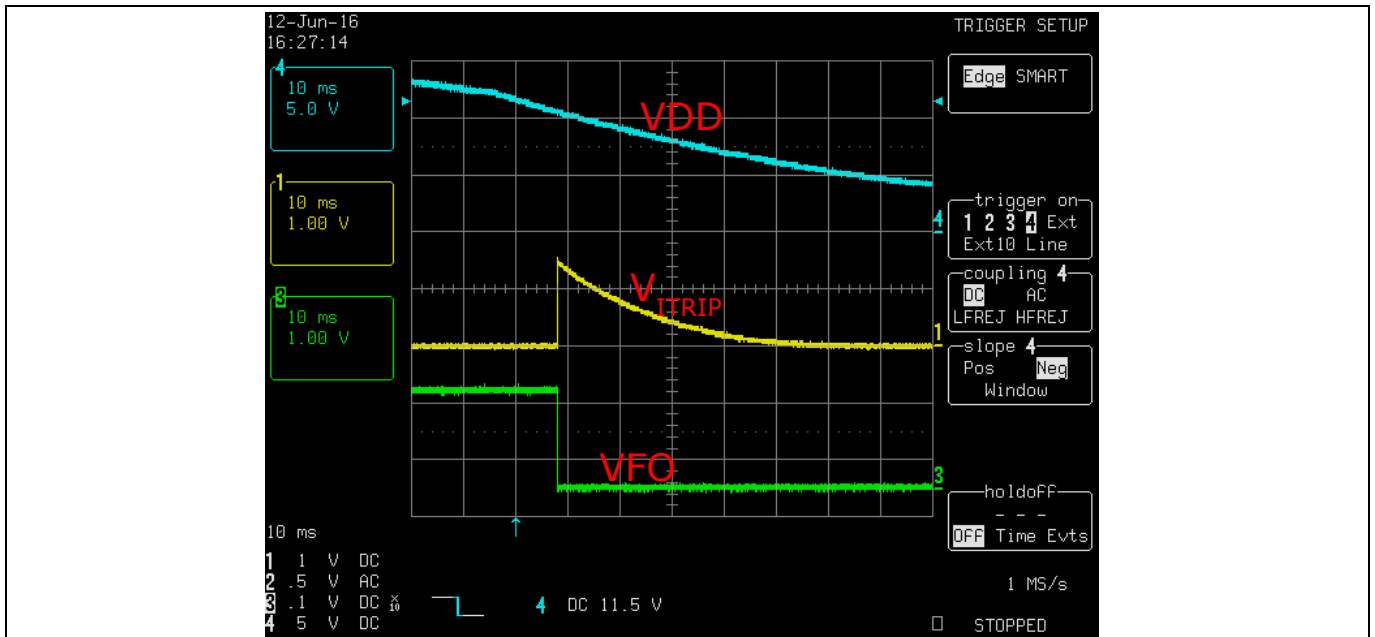

Figure 12 Power-off test waveform at pins VDD , ITRIP and VFO of CIPOS™ IPM

5.7.2 Overcurrent protection test waveform

Figure 13 and Figure 14 are the waveforms for overcurrent detection and recovery, respectively.

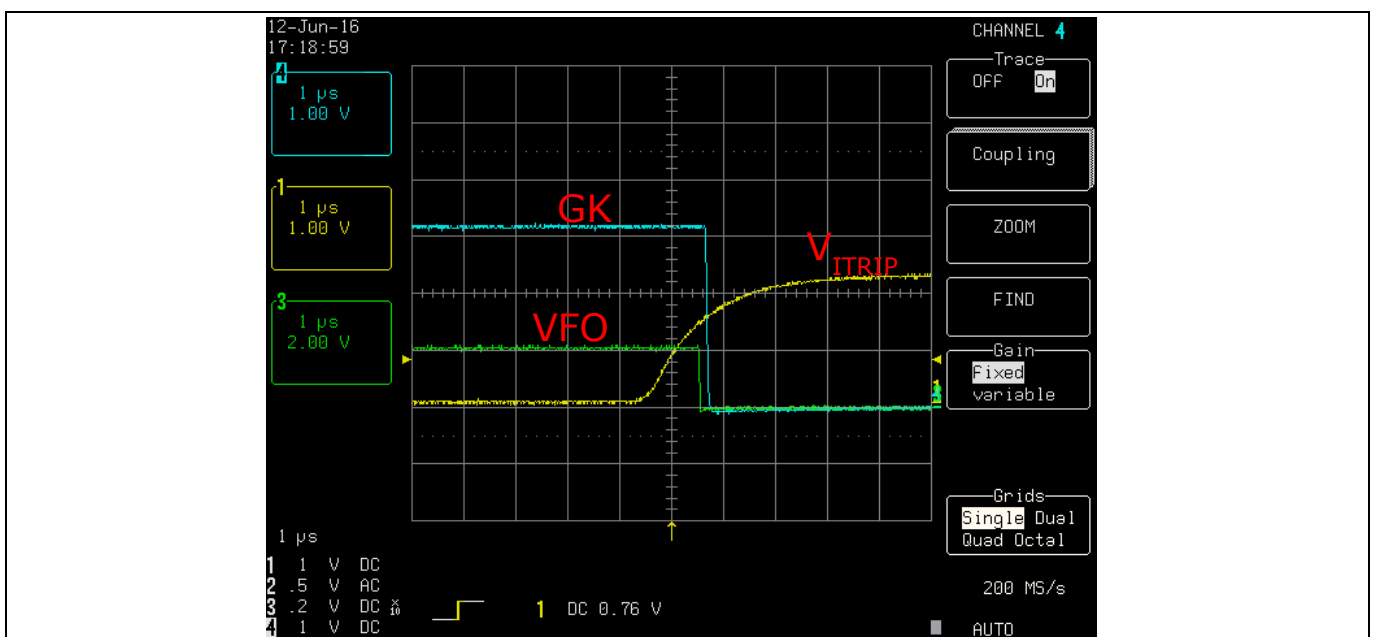

Figure 13 Overcurrent protection test waveform at pins VFO and ITRIP of CIPOS™ IPM

When the shunt current is higher than the protection value set, the output of U5A will be pulled up to 3.3 V. V_{ITRIP} will exceed ITRIP positive going threshold $V_{IT,TH+}$; VFO will be pulled down to 0V. After a delay controlled by R28 and C17, the NMOS U3 will be turned off to avoid an endless loop.

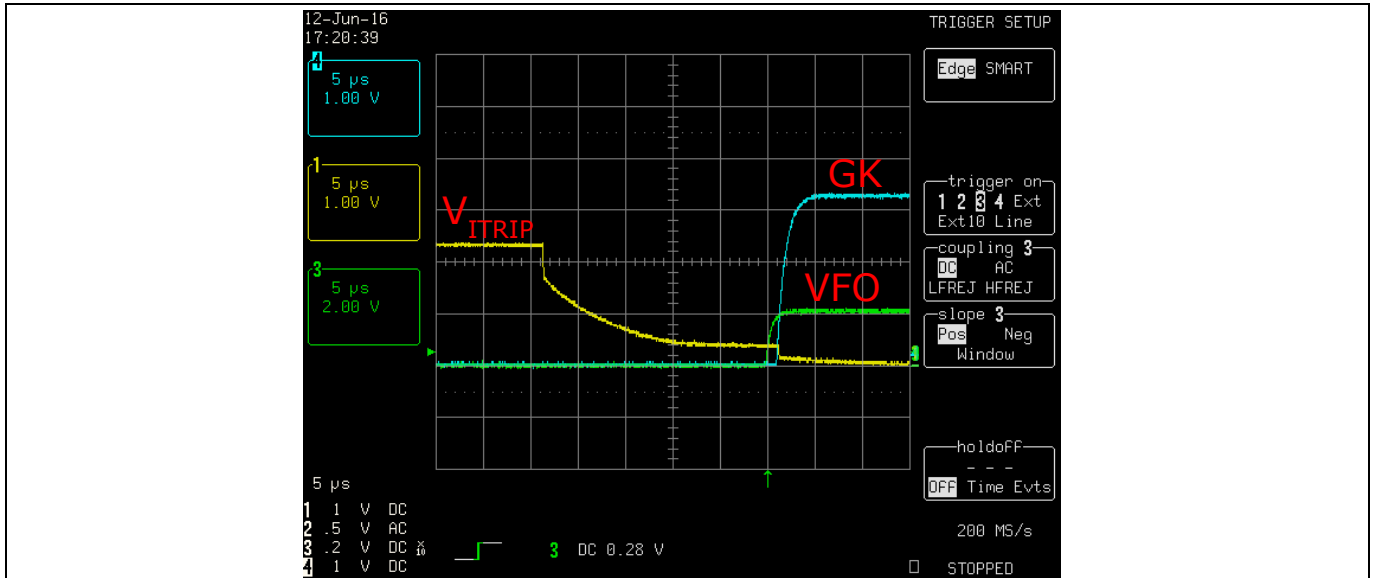

Figure 14 Overcurrent recovery test waveform at pins VFO and ITRIP of CIPOSTM IPM

5.7.3 Overtemperature protection test waveform

Due to the external pull-up resistor, the voltage at the VFO pin decreases as the thermistor temperature increases. GK indicates a module failure in case of under voltage at pin VDD or in case of triggered overcurrent or overtemperature detection at ITRIP.

When the temperature T_{NTC} is higher than the chosen protection temperature, the output of U5B will be pulled down to 0V. Then V_{ITRIP} will be pulled up higher than ITRIP positive going threshold $V_{IT,TH+}$. Some microseconds later which are controlled by R28 and C17, NMOS U3 will be turned off to avoid an endless loop. Both VFO and GK are a series of pulses as shown in Figure 15. The time GK is active is sufficient to have the microcontroller stop generating PWM pulses

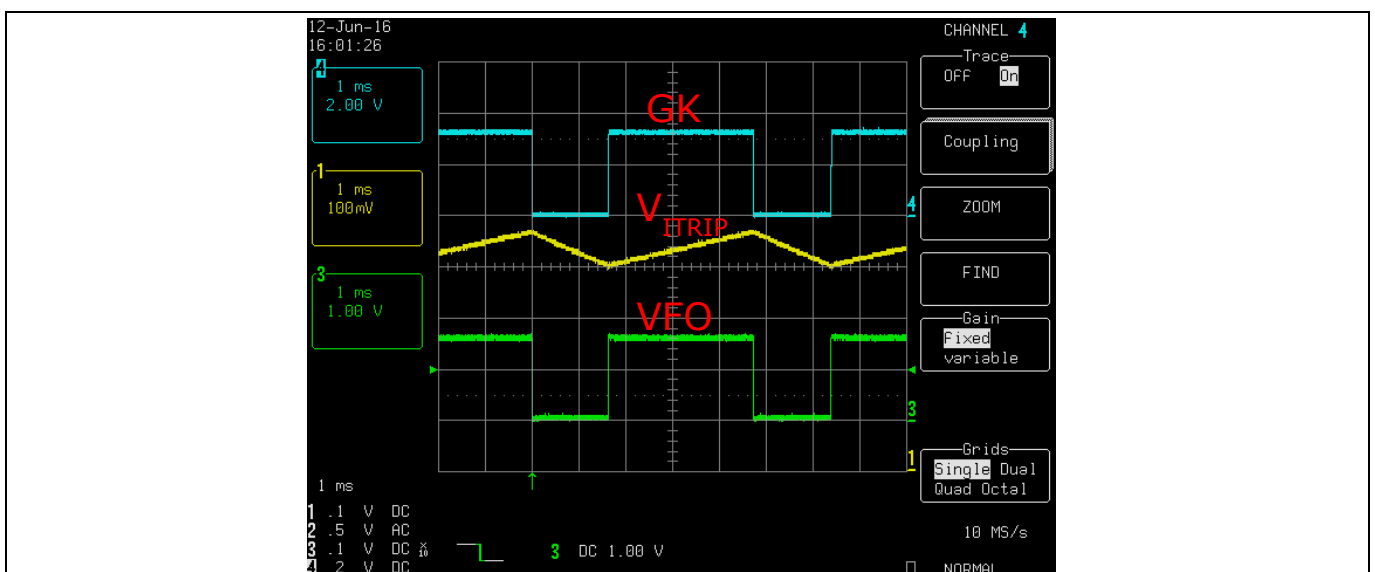

Figure 15 Waveform for Overtemperature detection

5.8 PCB Layout

The layout of this board can be used for different voltage or power classes. The PCB has two electrical layers with 35µm copper by default and its size is 120 mm × 120 mm. The PCB board thickness is 1.6mm. Get in contact with our technical support team to get more detailed information and the latest Gerber-files.

Figure 16 illustrates the top assembly print of the evaluation board.

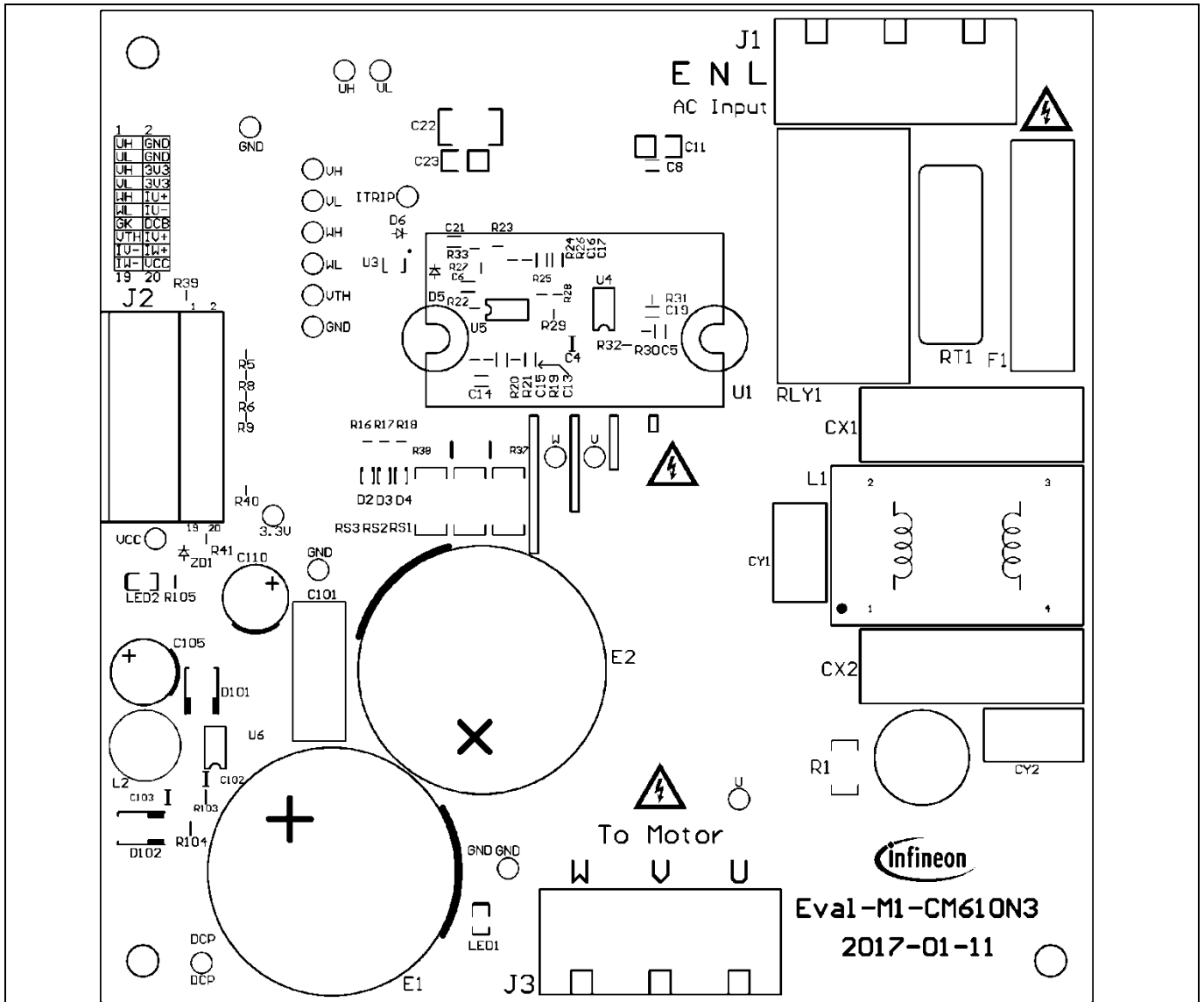

Figure 16 Top assembly print of the Eval-M1-CM610N3 evaluation board

Figure 17 depicts the bottom assembly print of the evaluation board.

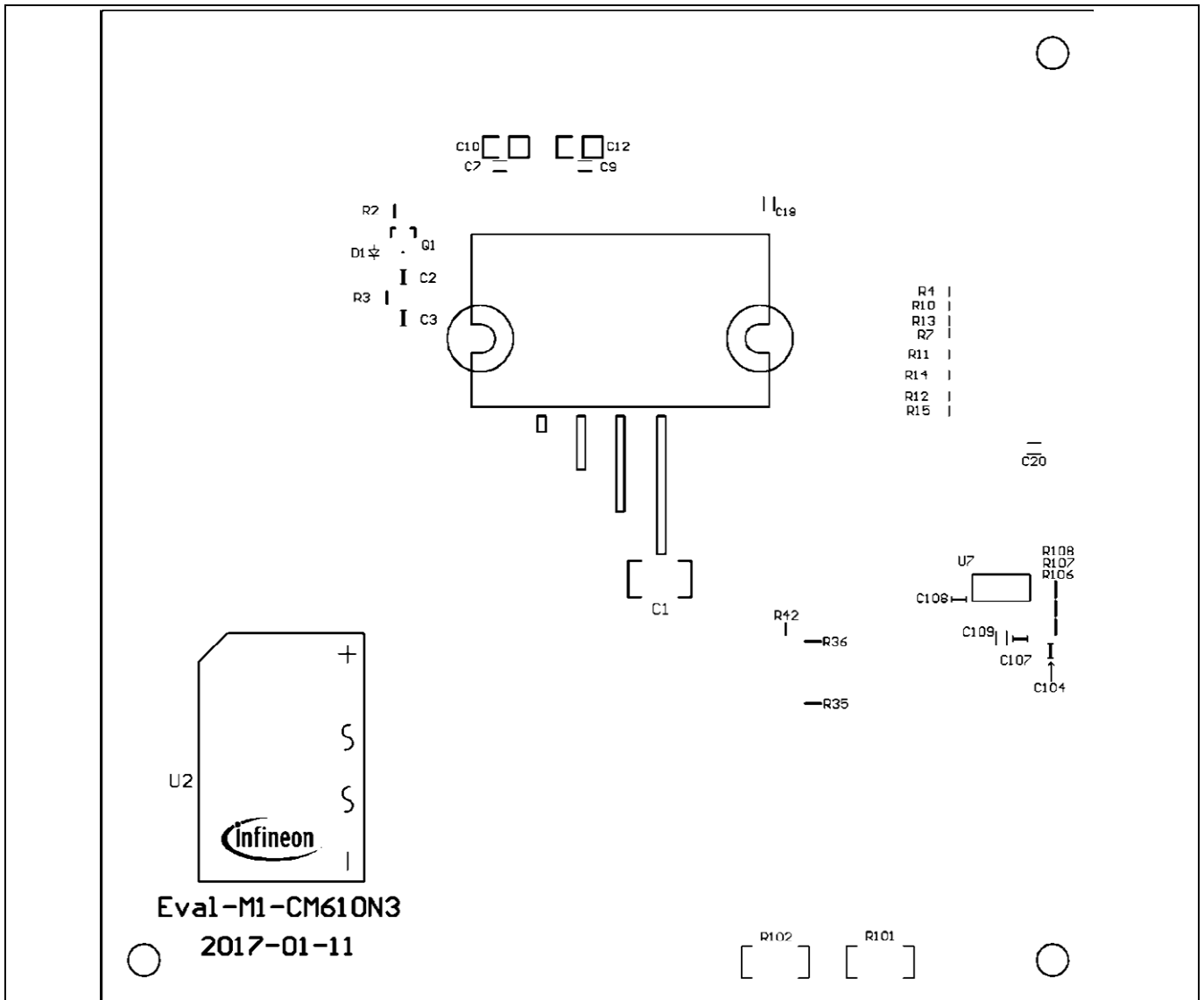

Figure 17 Bottom assembly print of the Eval-M1-CM610N3 evaluation board

The top layer routing of the PCB is provided in Figure 18.

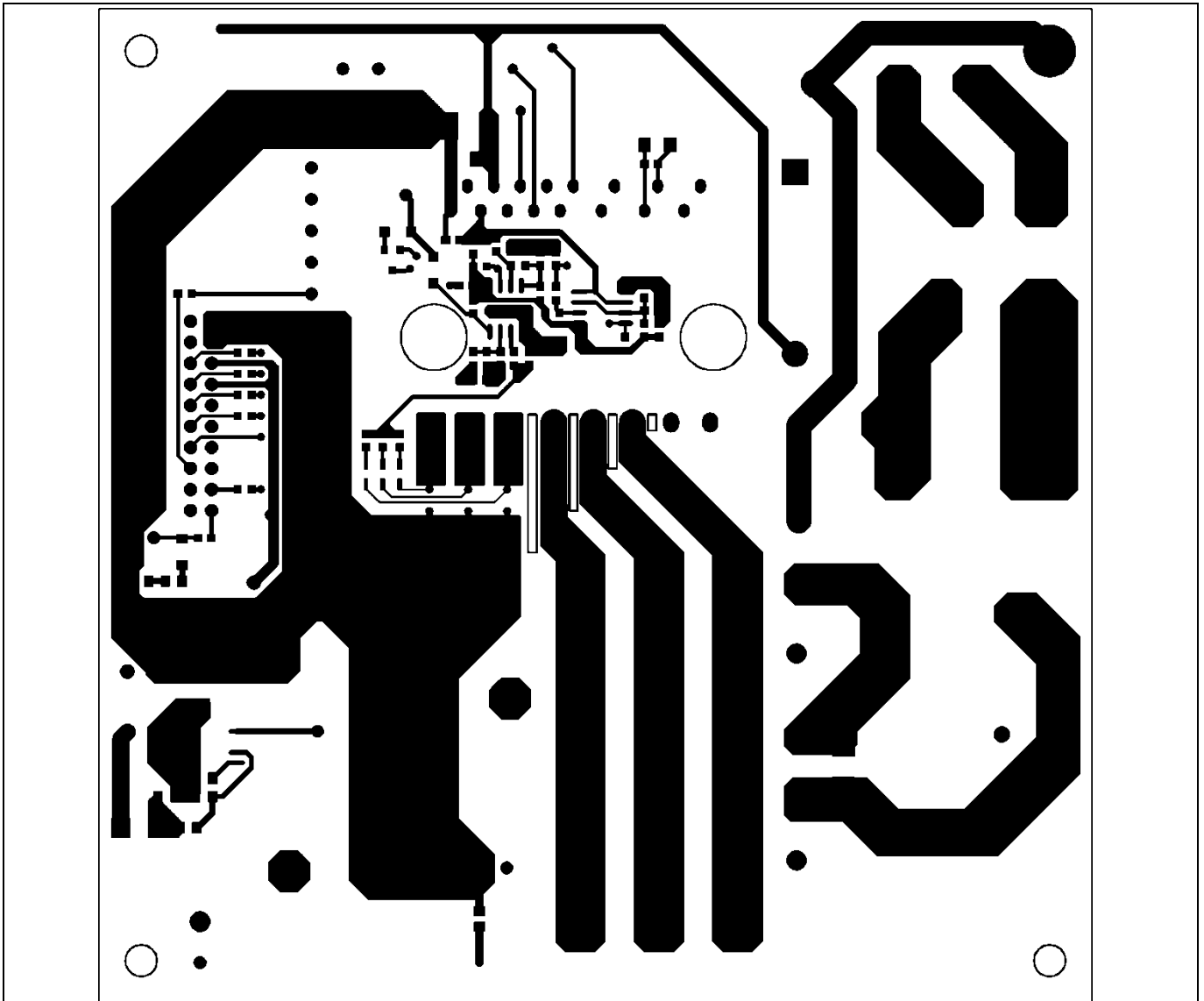

Figure 18 Top layer routing of the Eval-M1-CM610N3

Figure 19 illustrates the bottom layer routing of the PCB.

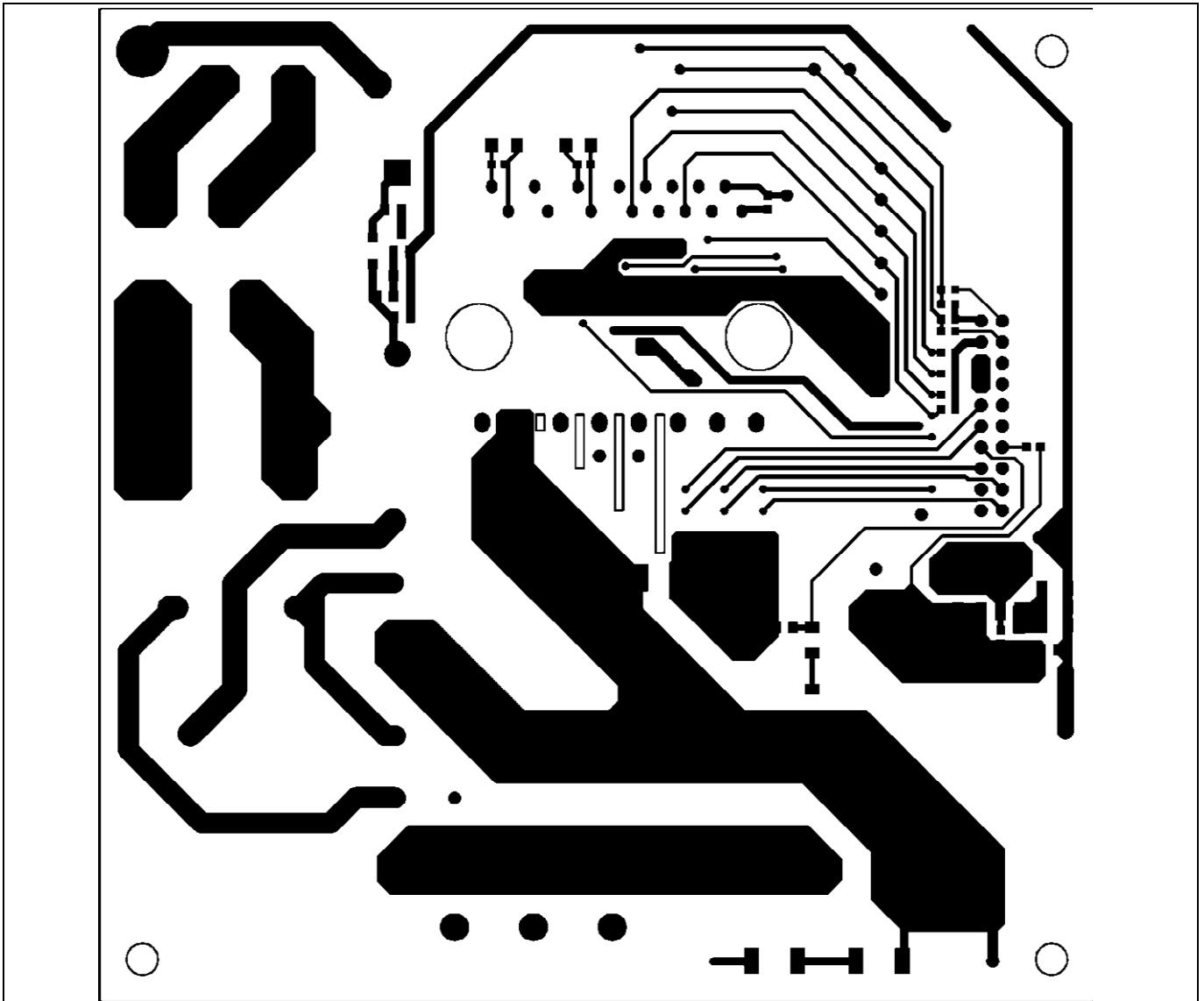

Figure 19 Bottom layer routing of the Eval-M1-CM610N3

6 Bill of Materials of Eval-M1-CM610N3

Table 7 provides the complete bill of materials of the evaluation board.

Table 7 Bill of materials

No.	Qty	Part description	Designator	Part number	Manufacturer
1	1	CAP CER 0.1μF 630V X7R 1812	C1	C4532X7R2J104K230KA	TDK Corporation
2	1	CAP CER 4.7μF 25V 0805	C2	TMK212AB7475KG-T	Taiyo Yuden
3	2	CAP CER 10μF 25V 0805	C3, C4	TMK212BBJ106KG-T	Taiyo Yuden
4	3	CAP CER 0.1μF 10V 0603	C5, C6, C14	0603ZC104KAT2A	AVX Corporation
5	3	CAP CER 0.1μF 25V 0603	C7, C8, C9	06033C104KAT2A	AVX Corporation
6	3	CAP CER 10μF 25V X7R 1206	C10, C11, C12	C1206C106K3RACTU	Kemet
7	5	CAP CER 470pF 10V 0603	C13, C15, C16, C19, C20	885012006012	Wurth Electronics Inc
8	1	CAP CER 0.47μF 10V 0603	C17	C0603C474K8RACTU	Kemet
9	2	CAP CER 4700pF 25V 0603	C18, C21	C0603C472K3RACTU	Kemet
10	1	CAP CER 10μF 25V 1812	C22	C4532X7R1E106K250KA	TDK Corporation
11	1	CAP CER 470pF 25V 1206	C23	885012208044	Wurth Electronics Inc
12	1	CAP FILM 0.1μF 630V RADIAL	C101	ECW-FA2J104J	Panasonic Electronic
13	1	CAP CER 0.1μF 25V 0805	C102	C0805C104K3RACTU	Kemet
14	1	CAP CER 10μF 25V 0805	C103	TMK212BBJ106KG-T	Taiyo Yuden
15	1	CAP CER 0.22μF 25V 0805	C104	C0805X224K3RAC7800	Kemet
16	1	CAP ALUM 220μF 35V RADIAL	C105	35ZLS220MEFC8X11.5	Rubycon
17	1	CAP CER 10nF 25V X7R 0603	C107	C0603C103M3RACTU	Kemet
18	1	CAP CER 1μF 25V 0805	C108	C0805C105K3RACTU	Kemet
19	1	CAP CER 0.1μF 10V X7R 0603	C109	C0603C104K8RACTU	Kemet
20	1	CAP ALUM 470μF 16V RADIAL	C110	16ZLH470MEFC8X11.5	Rubycon
21	2	CAP FILM 0.47μF 10% 275VAC RADIAL	CX1, CX2	MKP275VAC474PF	JIMSON
22	2	CAP CER 3300pF 440VAC Y5U RADIAL	CY1, CY2	ECK-ATS332ME	Panasonic Electronic Components
23	3	Diode GEN PURP 100V 300mA	D1, D5, D6	1N4148W-7-F	Diodes Incorporated
24	3	Diode SCHOTTKY 10V 3A	D2, D3, D4	BAT60AE6327HTSA1	Infineon Technologies
25	2	Diode Standard 600V 1A Surface Mount SMA	D101, D102	US1J-13-F	Diodes Incorporated
26	2	CAP ALUM 330μF 20% 400V SNAP	E1, E2	ESMQ401VSN331MR30S	United Chemi-Con
27	1	FUSE CERAMIC 8A 250VAC	F1	5HF-8	Bel Fuse Inc.

Bill of Materials of Eval-M1-CM610N3

No.	Qty	Part description	Designator	Part number	Manufacturer
28	2	CONN TERM BLOCK 3POS 9.52MM PCB	J1, J3	1714984	Phoenix Contact
29	1	CONN RCPT .100" 20PS DL R/A GOLD	J2	SSW-110-02-S-D-RA	Samtec Inc.
30	1	8108-RC	L1	JWMILLER_8108	Bourns, Inc.
31	1	FIXED IND 2.2mH THROUGH HOLE	L2	RLB0914-222KL	Bourns Inc.
32	1	LED RED CLEAR 0805 SMD	LED1	LTST-C171KRKT	Lite-On Inc.
33	1	LED GREEN CLEAR 0805 SMD	LED2	LTST-C171GKT	Lite-On Inc.
34	1	TRANS NPN 100V 1A SOT23-3	Q1	FMMT493TA	Diodes Incorporated
35	1	RES SMD 1MΩ 5% 3/4W 2010	R1	CRCW20101M00JNEF	Vishay Dale
36	1	RES SMD 91Ω 5% 1/8W 0805	R2	RC0805JR-0791RL	Yageo
37	2	RES SMD 3.3kΩ 5% 1/8W 0805	R3, R105	RMCF0805JT3K30	Stackpole Electronics Inc.
38	9	RES SMD 100Ω 1% 1/10W 0603	R4, R5, R6, R7, R8, R9, R16, R17, R18	RC0603FR-07100RL	Yageo
39	7	RES SMD 4.7kΩ 1% 1/10W 0603	R10, R11, R12, R13, R14, R15, R32	RC0603FR-074K7L	Yageo
40	1	RES SMD 1kΩ 1% 1/10W 0603	R19	RC0603FR-071KL	Yageo
41	1	RES SMD 24.3kΩ 1% 1/10W 0603	R20	RC0603FR-0724K3L	Yageo
42	1	RES SMD 5.6kΩ 1% 1/10W 0603	R21	RC0603FR-075K6L	Yageo
43	3	RES SMD 10kΩ 5% 1/10W 0603	R22, R27, R29	RC0603JR-0710KL	Yageo
44	4	RES SMD 0.0Ω JUMPER 1/10W 0603	R23, R39, R40, R41	RC0603JR-070RL	Yageo
45	2	RES SMD 4.7kΩ 1% 1/10W 0603	R25, R26	RC0603FR-074K7L	Yageo
46	1	RES SMD 110kΩ 5% 1/10W 0603	R28	RC0603JR-07110KL	Yageo
47	1	RES SMD 20kΩ 5% 1/10W 0603	R30	RC0603JR-0720KL	Yageo
48	1	RES SMD 5.1kΩ 5% 1/10W 0603	R31	RC0603JR-075K1L	Yageo
49	1	RES SMD 5.6kΩ 5% 1/10W 0603	R33	RMCF0603JT5K60	Stackpole Electronics Inc.
50	2	RES SMD 1MΩ 1% 1/3W 1206	R35, R36	HVCB1206FKC1M00	Stackpole Electronics Inc.
51	3	RES SMD 0.0Ω JUMPER 1/4W 1206 NO ASS.	R37, R38, R105	RMCF1206ZT0R00	Stackpole Electronics Inc.
52	1	RES SMD 4.87kΩ 1% 1/8W 0805 NO ASS.	R42	RMCF0805FT4K87	Stackpole Electronics Inc.
53	2	RES SMD 100kΩ 5% 1W 2512	R101, R102	RMCF2512JT100K	Stackpole Electronics Inc.
54	1	RES SMD 2kΩ 1% 1/8W 0805	R103	RC0805FR-072KL	Yageo

Eval-M1-CM610N3**iMOTION™ Modular Application Design Kit****Bill of Materials of Eval-M1-CM610N3**

No.	Qty	Part description	Designator	Part number	Manufacturer
55	1	RES SMD 15.8kΩ 1% 1/8W 0805	R104	RC0805FR-0715K8L	Yageo
56	3	RES SMD 300Ω 5% 1/4W 1206	R106, R107, R108	RMCF1206JT300R	Stackpole Electronics Inc.
57	1	RELAY GEN PURPOSE SPST 20A 12V	RLY1	G4A-1A-PE DC12	Omron Electronics Inc-EMC Div
58	3	RES SMD 0.1Ω 1% 2W 2512	RS1, RS2, RS3	PT2512FK-7W0R1L	Yageo
59	1	NTC thermistors for inrush current limiting	RT1	NTC5D-20	Yuanlindianzi
60	1	CIPOS™ Mini - 3 Phase 600V DIP IPM	U1	IKCM10H60GA	Infineon Technologies
61	1	RECT BRIDGE GPP 600V 25A GBJ	U2	GBJ2506-F	Diodes Incorporated
62	1	MOSFET N-CH 20V 4.2A SOT-23-3	U3	IRLML2502	Infineon Technologies
63	2	IC DUAL DIFF COMPARATOR 8- SOIC	U4, U5	LM393ADR	Texas Instruments
64	1	IC OFFLINE SWIT OCP 8SOIC	U6	LNK304DN	Power Integrations
65	1	Wide Input Range Low Noise 500mA LDO	U7	IFX1763XEJ V33	Infineon Technologies
66	1	DIODE ZENER 10V 500mW SOD123	ZD1	BZT52C10-7-F	Diodes Incorporated

7 Reference

[1] Datasheet of Infineon CIPOS™ mini IPM IKCM10H60GA, is available for download on Infineon's website

[2] Application Note AN2016-10 CIPOS Mini Technical Description, is available for download on Infineon's website



Revision History

Revision History

Major changes since the last revision

Version number	Revision Date	Revision description
1.0	2017-05-22	First release