

IGBT motor drives evaluation board in TO247 packages

EVAL-M5-IGBT7

About this document

Scope and purpose

This application note provides an overview of the evaluation board EVAL-M5-IGBT7 including its main features, key data, pin assignments, mechanical dimensions, and corresponding control card.

The EVAL-M5-IGBT7 is a complete evaluation board including the six discrete IGBTs realizing a B6 inverter for motor drive applications. In combination with control boards equipped with the M5 32-pin interface connector such as the XMC DriveCard 4400, it features and demonstrates Infineon's IGBT in motor drives.

The evaluation board EVAL-M5-IGBT7 was developed to support customers during their first steps in designing applications with IGBT.

Intended audience

This application note is intended for power electronic engineers evaluating the use of IGBT devices in drive applications.

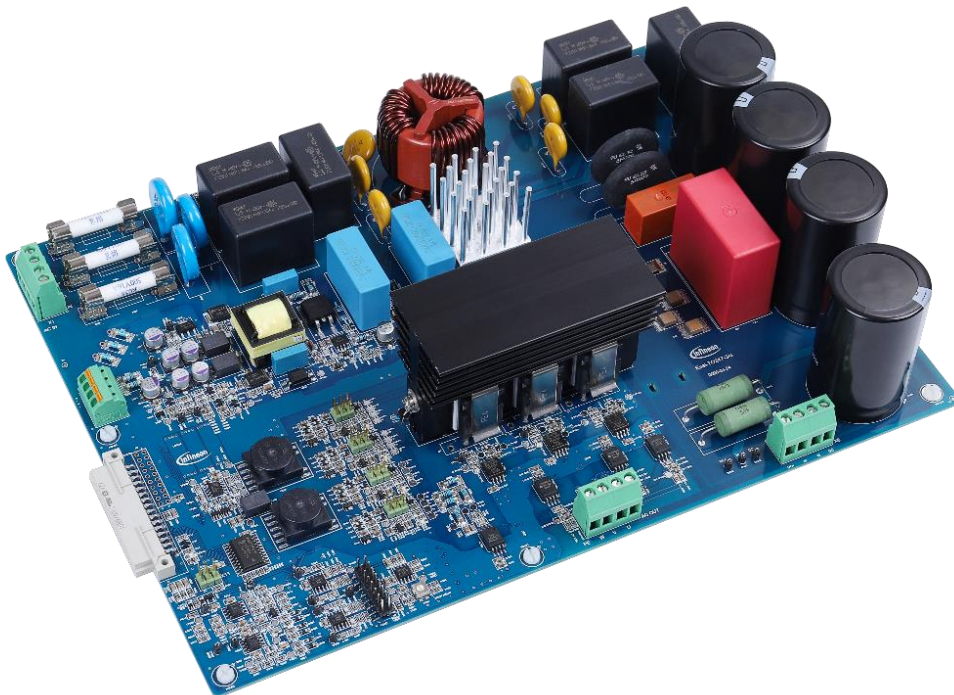









Table of contents

About this document.....	1
Table of contents.....	2
1 Safety precautions	3
2 Introduction	4
3 Main features.....	6
3.1 Functional Groups.....	7
3.2 Pin Assignments	8
3.3 Analog measurement adjustment.....	10
4 Demo control.....	12
4.1 Installing DEMO Guide User Interface (GUI)	12
4.2 Using the DEMO Guide User Interface for IGBT MADK	14
5 Schematics and Layout	16
5.1 Overview	16
5.2 Input Circuit.....	16
5.2.1 EMI Filter	17
5.3 Auxiliary Supply.....	17
5.4 Power Stage.....	19
5.5 Driver Circuit.....	19
5.6 Thermistor Output	22
5.7 Current Measurement	23
5.8 Voltage Measurement	23
5.9 Analog to digital converter	24
5.10 Overload and Overtemperature Protection.....	24
5.11 Overcurrent / Short Circuit Protection	25
5.12 PCB Layout	26
6 Measurements	27
6.1 Thermal measurements.....	28
7 Bill of Material	29
Revision history.....	36

1 Safety precautions

In addition to the precautions listed throughout this manual, please read and understand the following statements regarding hazards associated with development systems.

Table 1 Safety Precautions

	<p>Attention: The DC link potential of the EVAL-M5-IGBT7 system is connected to the grid input. When measuring voltage waveforms by oscilloscope, high voltage differential probes must be used. Failure to do so may result in personal injury or death. Darkened display LEDs are not an indication that capacitors have discharged to safe voltage levels.</p>
	<p>Attention: EVAL-M5-IGBT7 system contains DC bus capacitors which take time to discharge after removal of the main supply. Before working on the drive system, wait five minutes for capacitors to discharge to safe voltage levels. Failure to do so may result in personal injury or death. Darkened display LEDs are not an indication that capacitors have discharged to safe voltage levels.</p>
	<p>Attention: Only personnel familiar with the drive and associated machinery should plan or implement the installation, start-up and subsequent maintenance of the system. Failure to comply may result in personal injury and/or equipment damage.</p>
	<p>Attention: The surfaces of the drive may become hot, which may cause injury.</p>
	<p>Attention: EVAL-M5-IGBT7system contains parts and assemblies sensitive to Electrostatic Discharge (ESD). Electrostatic control precautions are required when installing, testing, servicing or repairing this assembly. Component damage may result if ESD control procedures are not followed. If you are not familiar with electrostatic control procedures, refer to applicable ESD protection handbooks and guidelines.</p>
	<p>Attention: A drive, incorrectly applied or installed, can result in component damage or reduction in product lifetime. Wiring or application errors such as under sizing the motor, supplying an incorrect or inadequate AC supply or excessive ambient temperatures may result in system malfunction.</p>
	<p>Attention: Remove and lock out power from the drive before you disconnect or reconnect wires or perform service. Wait five minutes after removing power to discharge the bus capacitors. Do not attempt to service the drive until the bus capacitors have discharged to zero. Failure to do so may result in personal injury or death.</p>
	<p>Attention: EVAL-M5-IGBT7system is shipped with packing materials that need to be removed prior to installation. Failure to remove all packing materials which are unnecessary for system installation may result in overheating or abnormal operating condition.</p>

Introduction

2 Introduction

The EVAL-M5-IGBT7 evaluation board is a part of the iMOTION™ Modular Application Design Kit for motor drives. These boards can easily be interfaced via the iMOTION™ MADK-M5 32-pin interface connector to control boards such as the XMC DriveCard 4400 or XMC DriveCard 1300. Infineon provides a demonstration program provided with XMC Drive Card 4400 platform, to control a mother board and demonstrates Infineon’s IGBT in motor drives.

This evaluation board is designed to be an easy-to-use power stage based on Infineon's discrete power IGBTs. The board is equipped with all assembly groups for sensorless field oriented control (FOC). It provides a three-phase AC-connector, EMI filter, rectifier, and a 3-phase output for connecting the motor. The power stage also contains isolated current, voltage, and temperature sensing circuits.

The features of this board are described in the design feature chapter of this document, whereas the remaining paragraphs provide information to enable the customers to copy, modify and qualify the design for production according to their own specific requirements.

Environmental conditions were considered in the design of the EVAL-M5-IGBT7. The design was tested as described in this document but not qualified regarding safety requirements or manufacturing and operation over the whole operating temperature range or lifetime. The boards provided by Infineon are subject to functional testing only. Evaluation boards are not subject to the same procedures as regular products regarding Returned Material Analysis (RMA), Process Change Notification (PCN) and Product Discontinuation (PD). Evaluation boards are intended to be used under laboratory conditions and by trained specialists only.

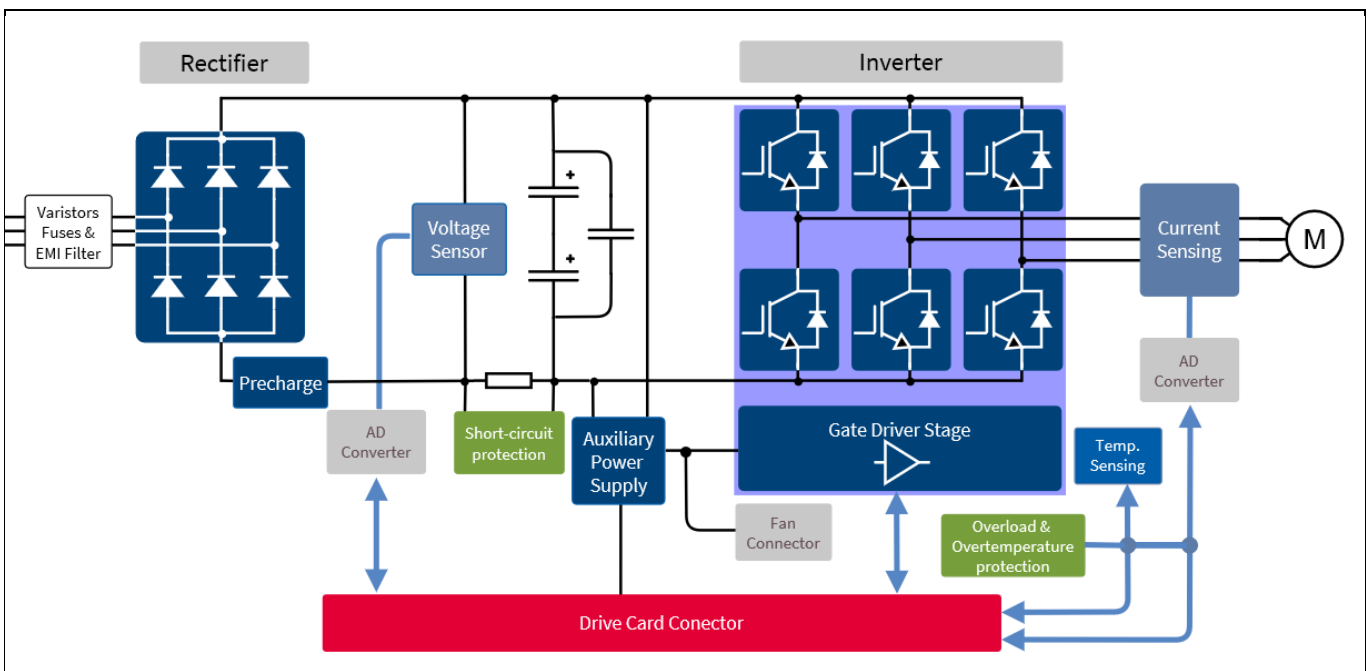

Figure 1 The block diagram of the EVAL-M5-IGBT7

The block diagram of the EVAL-M5-IGBT7 is depicted in Figure 1. This evaluation board includes an EMI filter, a line rectifier with a soft power up circuit, an auxiliary power supply to provide 5 V, and the IGBTs. All measuring and control signals are available on a 32-pin drive card interface connector. The hardware circuit regarding overtemperature and overcurrent protection is also included in this power board.

Introduction

The signal part of this evaluation board is fully separated from the power part by basic insulation. Whereas the power components are on grid potential, the signal part is earthed by the input connector. The design can be upgraded easily to safe electrical insulation by replacing the present IGBT drivers (X.U150, X.U151) and the auxiliary power supply transformer (T650) by parts with an appropriate safety approval.

Main features

3 Main features

The EVAL-M5-IGBT7 is an evaluation board for motor drive applications comprising IGBT technology. Combined in a kit with one of the available MADK control board options, it demonstrates Infineon’s IGBT power technology used in discrete IGBT.

The evaluation board characteristics are:

- Input voltage 340~480 V_{AC}
- Peak 11 kW motor power output
- On board EMI filter
- Basic insulation between power and signal part
- Isolated current sensing with $\Delta\Sigma$ -ADC
- Isolated sensing of dc-link voltage by $\Delta\Sigma$ -ADC
- Thermistor output
- Overload and short-circuit hardware protection
- Overtemperature hardware protection
- All six switches turn off during protection
- Rugged gate driver technology with stability against transient and negative voltage
- Auxiliary power supply with 5 V
- Measurement test-points compatible with standard oscilloscope probes
- PCB is 259 mm x 204 mm and has four layers with 35 μ m copper each
- RoHS complaint

Table 2 depicts the important specifications of the evaluation board EVAL-M5-IGBT7 for IKW40N120CS7 device.

Table 2 EVAL-M5-IGBT7 board specifications for IKW40N120CS7 device.

Parameters	Values	Conditions / Comments
Input		
Voltage	340 – 480 V _{rms}	lower AC input, less motor power output
Current	16 A _{rms}	Input 400 V _{AC} , T _a = 25 °C
Output		
Power (3 phases) with forced cooling	Up to 6 kW	input 400 V _{AC} , f _{PWM} = 8 kHz, T _a = 25 °C, forced convection cooling
DC bus voltage		
Typical DC bus voltage	530 V – 670 V	
Brown-in Aux-supply	480 V	
Brown-out Aux-supply	300 V	
Maximum DC bus voltage	720 V	
Switching frequency		
Nominal switching frequency f _{nom}	8 kHz	
Maximal switching frequency f _{max}	12 kHz	
Current feedback		
Analog output	38,3 mV/A	
Digital output	5 V	$\Delta\Sigma$ bitstream @ 20 MHz
DC link voltage feedback		
Analog output	5 mV/V	

Main features

Digital output	5 V	$\Delta\Sigma$ bitstream @ 20 MHz
Protections		
Output current trip level	60 A _{peak}	Disables driver stage for 30 ms
Temperature trip level	110 °C	Disables driver stage for 30 ms
On board power supply		
+5 V	± 2 %	Used for primary side of IGBT drivers and for the controller board
+6 V	± 10 %	Used for analog circuits
-5 V	± 10 %	Used for analog circuits
-15 V	± 5 %	Used for driver supply
System environment		
Ambient temperature	From 0 to 50 °C	Non-condensing, maximum RH of 95 %
PCB characteristics		
Material	FR4, 1.6mm thickness	4 layers, 35 μ m copper thickness
Dimensions	259 mm x 204 mm	

3.1 Functional Groups

Figure 2 points out the functional groups of the evaluation board. The functional groups are explained in Table 3.

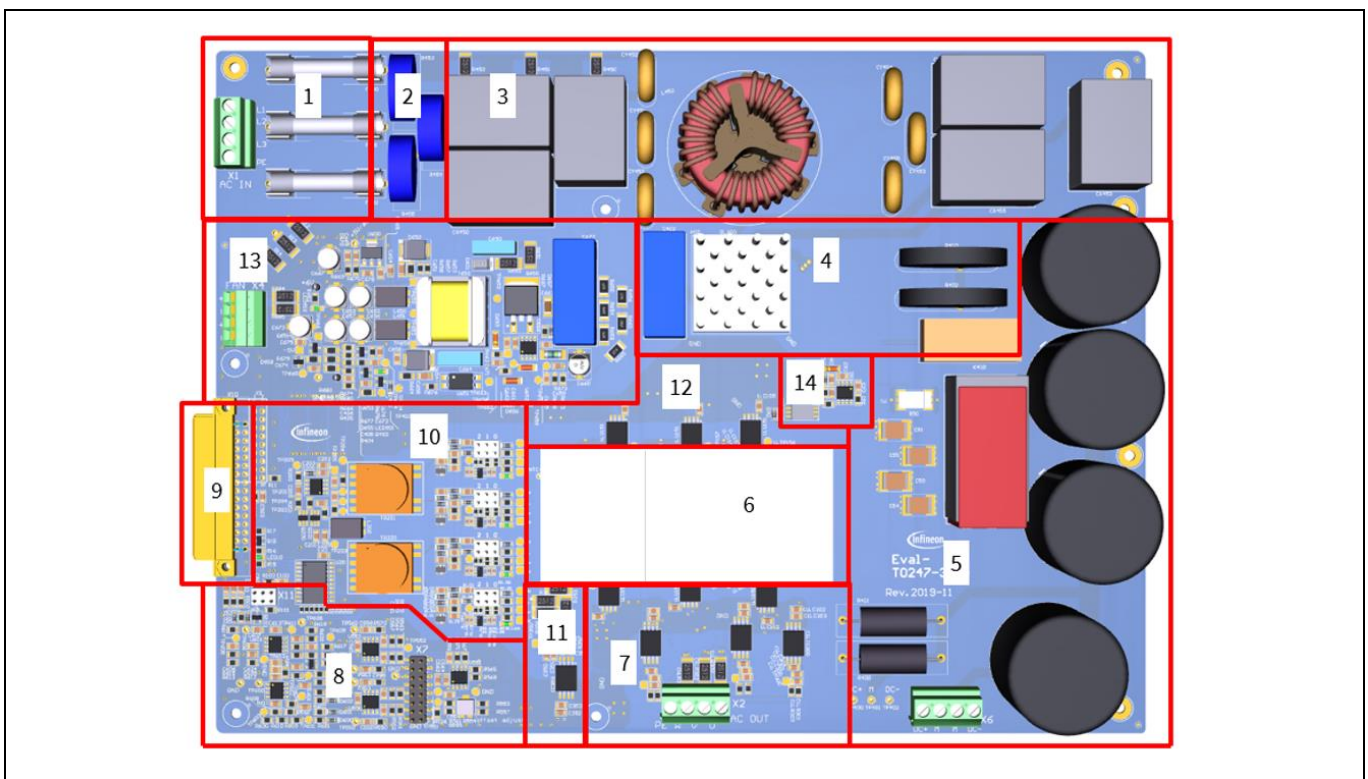

Figure 2 Top view of the EVAL-M5-IGBT7

Main features

Table 3 Functional Groups of EVAL-M5-IGBT7

Nr.	Functional groups
1	AC Input connector with fuses
2	Varistors for overvoltage protection
3	EMI filter
4	Rectifier with precharge relay and precharge NTC resistors
5	DC-bus capacitors, balancing resistors and DC-bus connector
6	Power stage: 6 IGBTs TO-247 with heatsink and phase current shunts
7	High-side IGBT drivers with $\Delta\Sigma$ -ADCs for shunt sensors
8	Low-pass filter of $\Delta\Sigma$ -signals and overcurrent comparators
9	Connector for controller
10	Isolated power supply for IGBT drivers
11	DC-bus voltage measurement with $\Delta\Sigma$ -ADC
12	Low-side IGBT drivers
13	Flyback converter for auxiliary supply
14	Overcurrent detection and measuring shunt

3.2 Pin Assignments

General information about the connectors of the EVAL-M5-IGBT7 evaluation board is reported. Table 4 includes the details of the AC input connector X1.

Table 4 X1 – AC line connector

S. No.	Pin	Details
1	Line phase 1	
2	Line phase 2	
3	Line phase 3	
4	EARTH	

Table 5 provides the details of the motor side connector X2.

Table 5 X2 – Motor side connector

S. No.	Pin	Details
1	EARTH	Connected to X1/4
2	U	Connect to motor phase W
3	V	Connect to motor phase V
4	W	Connect to motor phase U

Table 6 provides the pin assignments of driver board connector X10. This connector is the interface to the controller board.

Main features

Table 6 X10 – Power Board Connector

S. No.	Pin	Details
A1	-	n. c.
A2	-	n. c.
A3	-	n. c.
A4	-	n. c.
A5	-	n. c.
A6	-	n. c.
A7	-	n. c.
A8	-	n. c.
A9	-	n. c.
A10	I_W	Phase W current sense output, scale 76,56 mV/A, offset 2,5 V
A11	I_V	Phase V current sense output, scale 76,56 mV/A, offset 2,5 V
A12	I_U	Phase U current sense output, scale 76,56 mV/A, offset 2,5 V
A13	-	n. c.
A14	-	n. c.
A15	-	n. c.
A16	GND	Ground
B1	/ENABLE	/ENABLE signal – if high drivers are disabled
B2	/FAULT	/FAULT signal – active low when overcurrent or overtemperature is detected
B3	PWMWH	3.3 V compatible logic input for high side gate driver-Phase W
B4	PWMWL	3.3 V compatible logic input for low side gate driver-Phase W
B5	PWMVH	3.3 V compatible logic input for high side gate driver-Phase V
B6	PWMVL	3.3 V compatible logic input for low side gate driver-Phase V
B7	PWMUH	3.3 V compatible logic input for high side gate driver-Phase U
B8	PWMUL	3.3 V compatible logic input for low side gate driver-Phase U
B9	-	n. c.
B10	-	n. c.
B11	-	n. c.
B12	-	n. c.
B13	DCBsense	DC bus voltage sense output, scale 5 mV/V (1/200)
B14	VTH	Thermistor voltage output, 100°C = 0,448 V
B15	-	n. c.
B16	VCC	On board 5 V supply, max. 120 mA

Table 7 denotes the details of the fan connector X4. The connector is provided for two fans with a nominal voltage of 12 V cooling the heatsinks. The maximum output current is limited to 180 mA. The connector is connected via two series resistors to a supply of 15 V. Consequently, it is possible to drive the most fans with a nominal voltage of 12 V in the power range of 0.6 W to 1 W in their allowed voltage range.

Table 7 X4 – Fan connector

S. No.	Pin	Details
1	Fan1-	Connected via 8.2 Ω resistor to -15 V, max. 180 mA
2	Fan1+	Connected via 8.2 Ω resistor to GND, max. 180 mA
3	Fan2-	Connected to Fan1-
4	Fan2+	Connected to Fan1+

Main features

Table 8 includes the details of the dc bus connector X6.

Table 8 X6 – DC bus connector

S. No.	Pin	Details
1	DC+	Connected to positive side of DC-bus capacitor
2	DC M	Connected to midpoint of DC-bus capacitor
3	DC- M	Do not connect load at this point!
4	DC-	Connected to negative side of DC-bus capacitor

The following table provide the details of the digital measurements connector X7.

Table 9 X7 – $\Delta\Sigma$ measurement connector

S. No.	Pin	Details
1	Clock_lu	20 MHz clock output, signal level 5 V
2	GND	
3	DS_lu	$\Delta\Sigma$ modulated output of current measurement, phase U, signal level 5 V, 50 %positive equals 0 A, 89.06 % positive equals +50 A, 10.94 % positive equals -50 A
4	GND	
5	Clock_lv	20 MHz clock output, signal level 5 V
6	GND	
7	DS_lv	$\Delta\Sigma$ modulated output of current measurement, phase V, signal level 5 V, 50 %positive equals 0 A, 89.06 % positive equals +50 A, 10.94 % positive equals -50 A
8	GND	
9	Clock_lw	20 MHz clock output, signal level 5 V
10	GND	
11	DS_lw	$\Delta\Sigma$ modulated output of current measurement, phase W, signal level 5 V, 50 %positive equals 0 A, 89.06 % positive equals +50 A, 10.94 % positive equals -50 A
12	GND	
13	Clock_Vdc	20 MHz clock output, signal level 5 V
14	GND	
15	DS_Vdc	$\Delta\Sigma$ modulated output of dc link voltage measurement, signal level 5 V, 50 %positive equals 0 V, 89.06 % positive equals 851 V
16	GND	

3.3 Analog measurement adjustment

To achieve precise measurement of the output currents and a symmetric overcurrent detection, the offset voltage of the analog signals must be adjusted. All relevant parts for the adjustment of the offset voltage are shown in Figure 3.

Main features

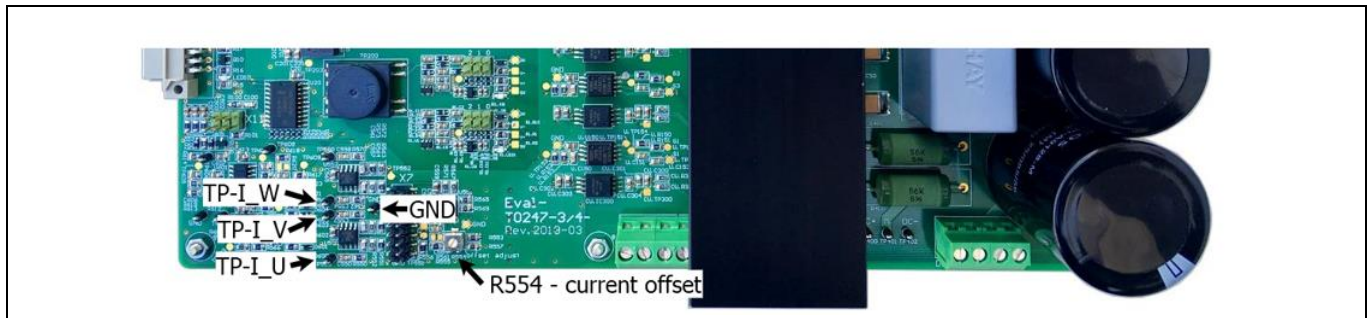

Figure 3 Relevant parts for offset adjustments

The DC-bus voltage measurement has only a small deviation, consequently, there is no offset compensation necessary. To adjust the current offset simply vary R554 at no load until either the software readings of the currents are zero or the voltages at the currents' test points reach almost 2,5 V. Due to component tolerances an exact adjustment of all three currents to zero at the same time will not be possible. Additional Information about the circuit itself can be found in the chapter "5.9 Analog to digital converter".

4 Demo control

The IGBT platform is intended for use with various power stages with different control boards. These boards can easily be interfaced via the iMOTION™ MADK-M5 32-pin interface connector to control boards such as the XMC DriveCard 4400 or XMC DriveCard 1300. Infineon provides a demonstration program provided with XMC Drive Card 4400 platform, to control a mother board and demonstrates Infineon's IGBT in motor drives. A detailed description of the XMC4400 drive card can be found online:

https://www.infineon.com/cms/en/product/evaluation-boards/kit_xmc4400_dc_v1/

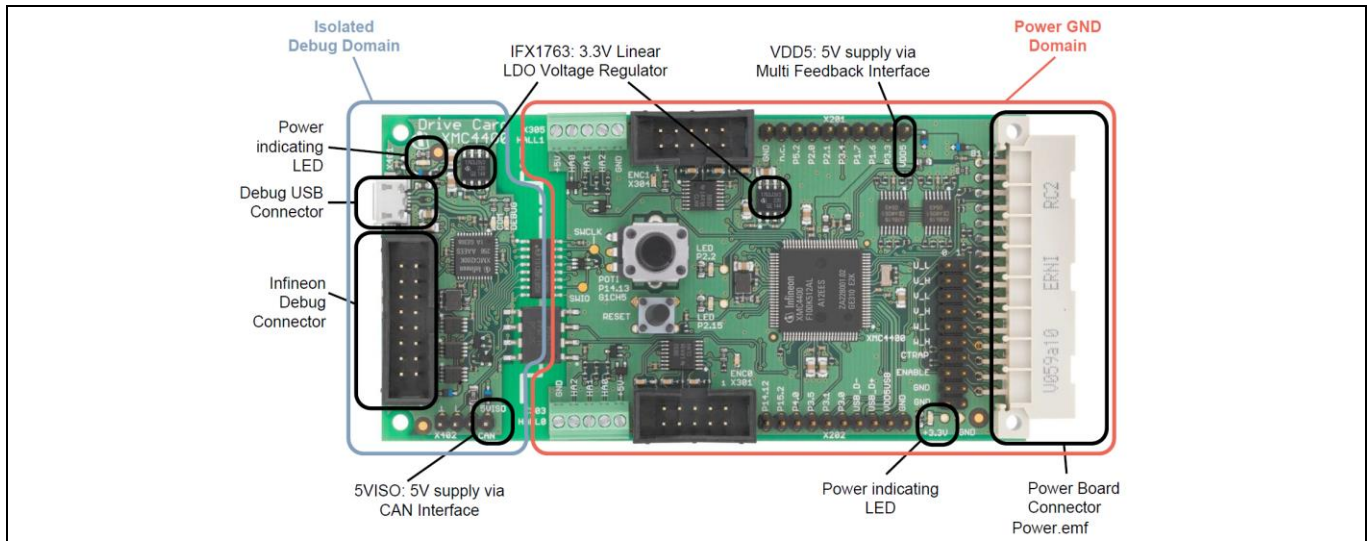

Figure 4 XMC drive card overview

4.1 Installing DEMO Guide User Interface (GUI)

Infineon provides a GUI control for this board for demonstration purpose only. Please note that such control is only for easiness to use the MADK board, only limited functions and protections are included. Infineon cannot provide extra technical supports for code modification.

This section describes how to install the Infineon DEMO GUI and what are the pre-required softwares that need to be installed, before using the software.

Prerequisites for usage of DEMO GUI from Infineon (follow the instructions from provider to install):

- Windows 10 Enterprise
- User interface for programming target Flash memory, like the “J-Flash Lite” that is a part of the J-Link software pack, available here:
<https://www.segger.com/downloads/jlink/#JLinkSoftwareAndDocumentationPack>
- XMCTM Flasher tool for XMCTM MCU Flash programming:
<https://www.infineon.com/cms/en/product/microcontroller/32-bit-industrial-microcontroller-based-on-arm-cortex-m/#!tools>
- The latest version of Microsoft .NET Framework
- Infineon GUI software package provided with the setup (unzip to preferred location) or download it from the website
- Micro USB cable Type-B

Demo control

- XMC 4400 operate only when a 5 V is applied to the pins A1 and B1 (Evaluation board has included internal power supply)

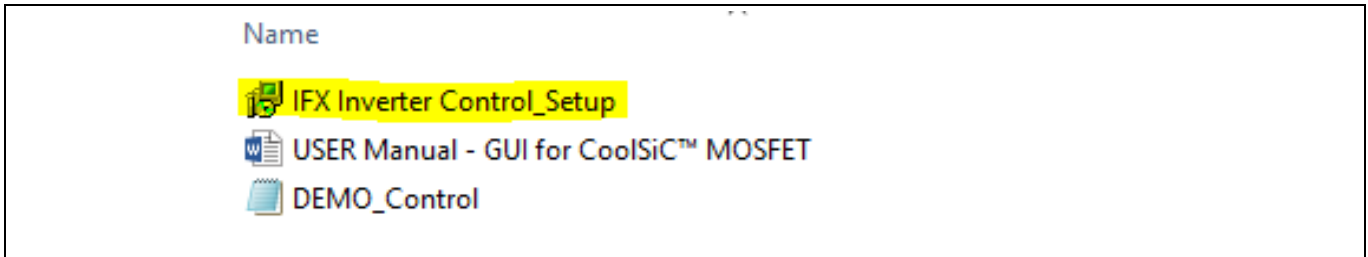
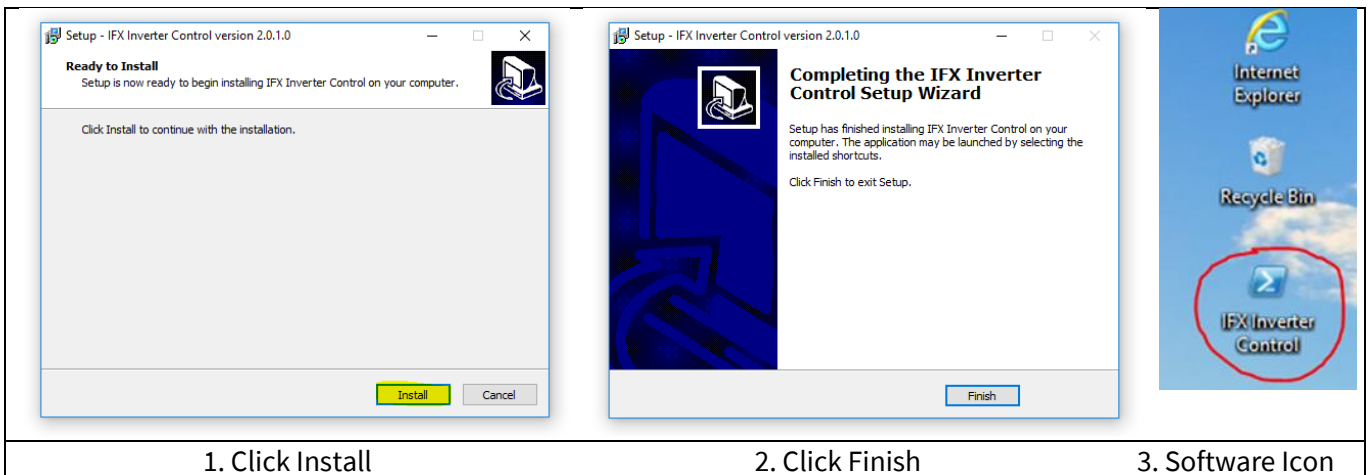

Figure 5 GUI execution files

When provided package is unzipped, the user needs to install the software package called **IFX Inverter Control Setup**. The user should be able to use the software in 8 easy steps as presented below.



1. Click Install

2. Click Finish

3. Software Icon

Figure 6 Installation process of IFX Inverter Control Setup software

While opening the IFX Inverter Control Setup, by default an empty GUI with no parameters is available. Therefore, it is necessary to open a provided GUI configuration like it is shown in Figure 7.

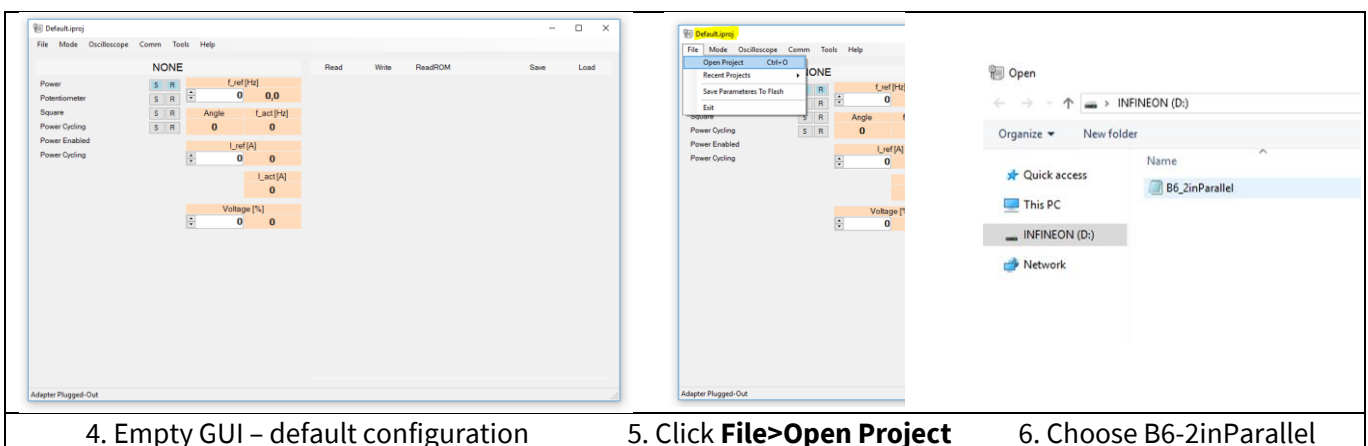

4. Empty GUI – default configuration

5. Click **File>Open Project**

6. Choose B6-2inParallel

Figure 7 Configuration of Infineon DEMO Graphical User Interface

Infineon’s software gives users a feedback about the current status, if any devices are connected to the GUI (computer) as shown in Figure 8 (NONE – board is connected). The same indication is written at the below of the software as Adapter Plugged Out.

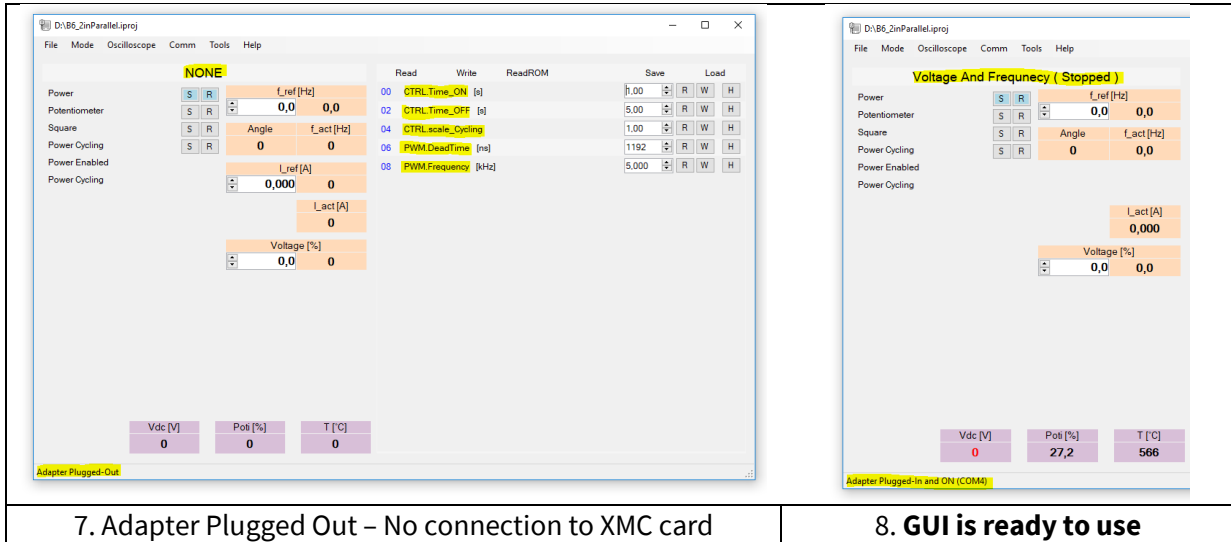

7. Adapter Plugged Out – No connection to XMC card

8. GUI is ready to use

Figure 8 Inactive Software – No board connected to the computer

When the XMC driver card is connected with the computer, the software automatically recognizes the controller. The software will show the status Adapter Plugged-in and ON (COMX). The software needs to be restarted in case of connecting the controller, when the software has been started before.

4.2 Using the DEMO Guide User Interface for IGBT MADK

By following the instructions in previous sections, the user could start operating now the IGBT motor drives evaluation board with provided demo software.

This section will show an example, how to use Infineon’s DEMO GUI for controlling the evaluation board and test the performance of IGBTs in the motor drive application.

Figure 9 illustrates a step by step process of an example, how to use the DEMO control in the application

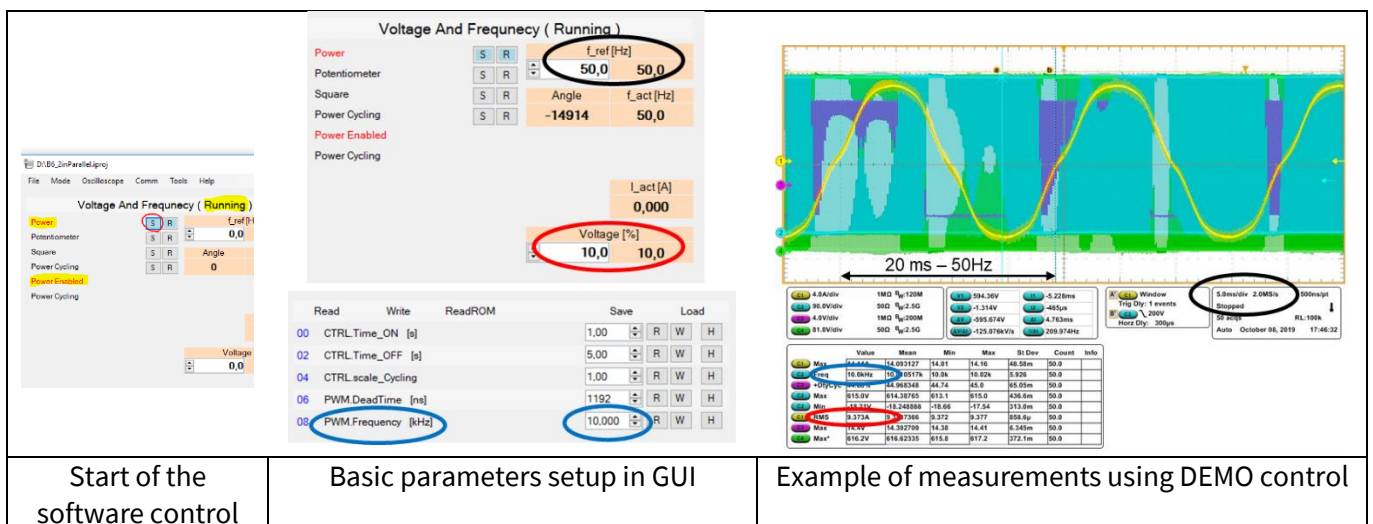

Figure 9 Example 1 – Changing main parameters of the Infineon DEMO control

The user has the possibility to change four basic parameters of the DEMO control:

- Phase fundamental/current frequency [Hz],
- Voltage Duty Cycle [%],

User Manual

EVAL-M5-IGBT7

Demo control

- Switching frequency [kHz],
- Dead Time [ns]

In addition the user can define a different testing load profile by changing two time periods and the scale factor of duty cycle. Figure 10 shows an example, how to create a testing load profile. This allows to test the devices at different load profiles, like the 3xI_{nom}, for a short time pulse.

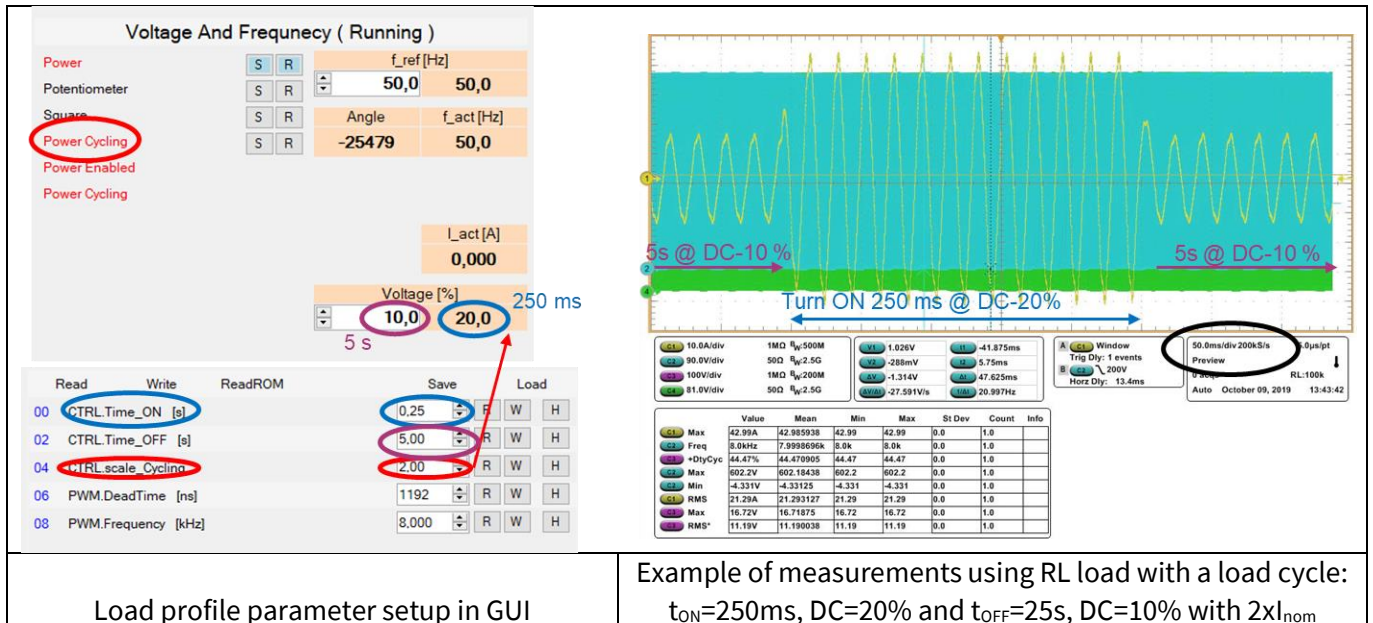

Load profile parameter setup in GUI

Example of measurements using RL load with a load cycle:
 $t_{ON}=250ms$, DC=20% and $t_{OFF}=25s$, DC=10% with $2xI_{nom}$

Figure 10 Example 2 – Defining a load profile with Infineon DEMO control

5 Schematics and Layout

5.1 Overview

An overview of the board's schematics is given in Figure 11. The schematic can be divided into four subcategories: the input circuit of the converter, the auxiliary supply, the power stage, and the measurements. The external controller board has to be connected to the evaluation board by the driver board connector X10. The logical ground is connected to the earth by the resistors R12 to R14. Alternatively, the board can be equipped with an iMOTION™ MADK M1 20 pin interface connector in a different population variant.

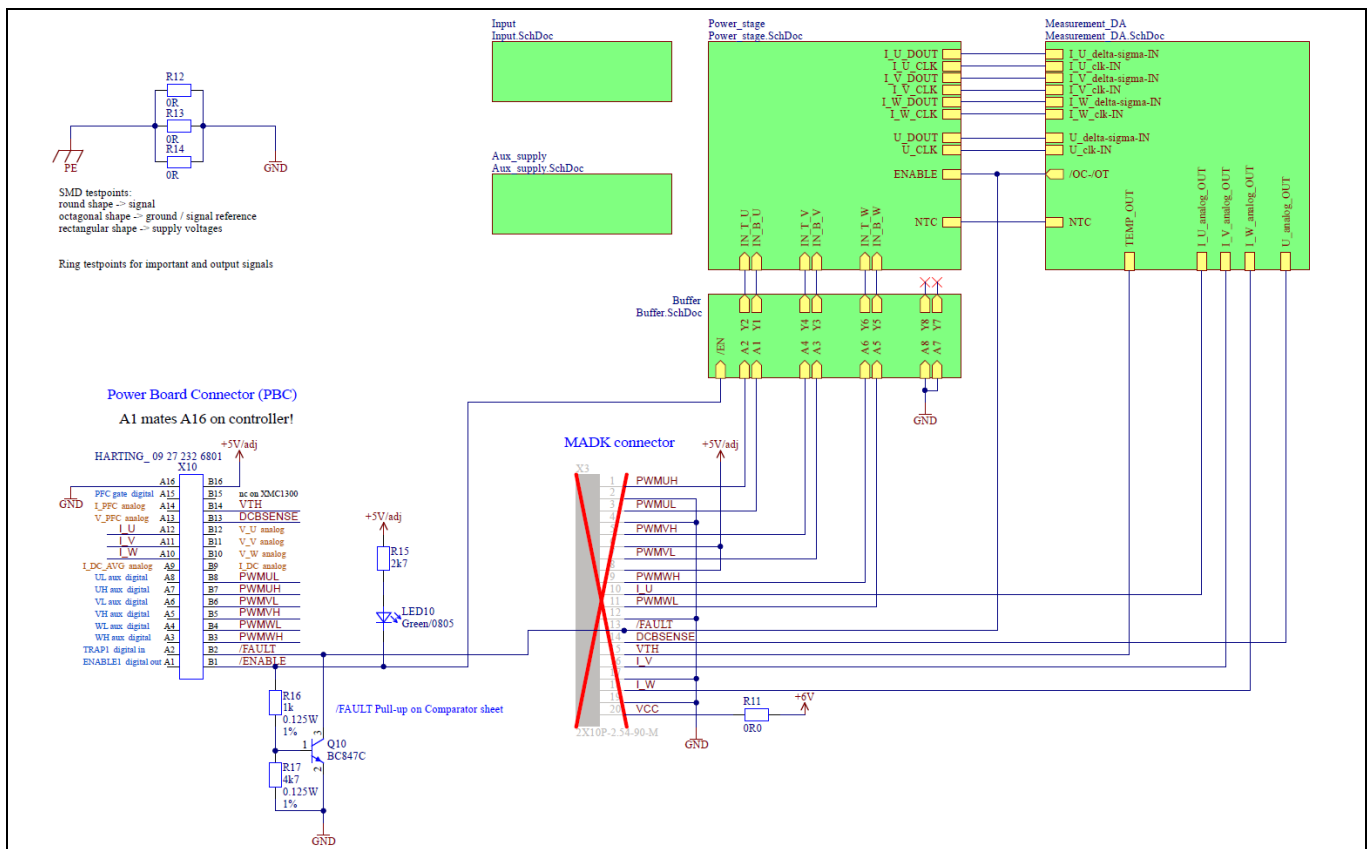

Figure 11 Overview and driver board connector

5.2 Input Circuit

The input circuit is shown in Figure 12. It is equipped with two NTC resistors, which limit the inrush current. The resistors are bypassed after the start of the auxiliary supply and a constant delay time. The DC-bus consists of four electrolytic capacitors and one film capacitor as well as four ceramic capacitors for the high frequency ripple currents. The electrolytic capacitors are series connected and balanced with two resistors.

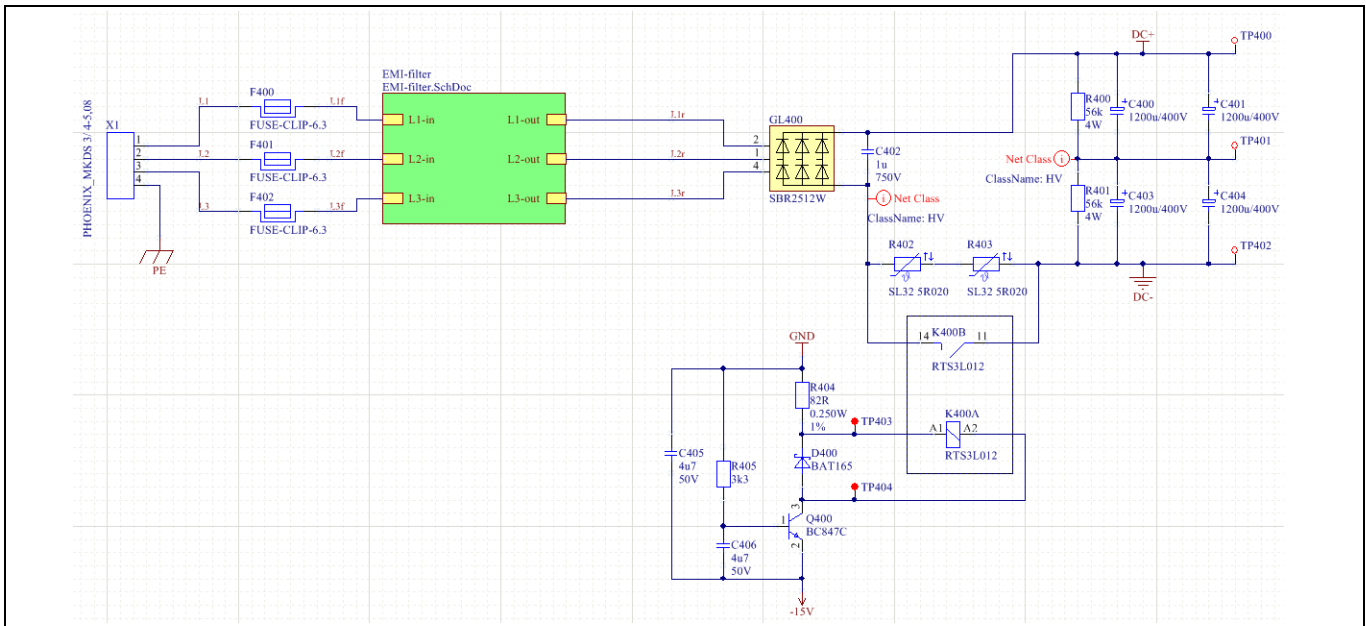

Figure 12 Mains input and precharge circuit

5.2.1 EMI Filter

The EVAL-M5-IGBT7 is equipped with an EMI filter circuit. The circuit is depicted in Figure 13.

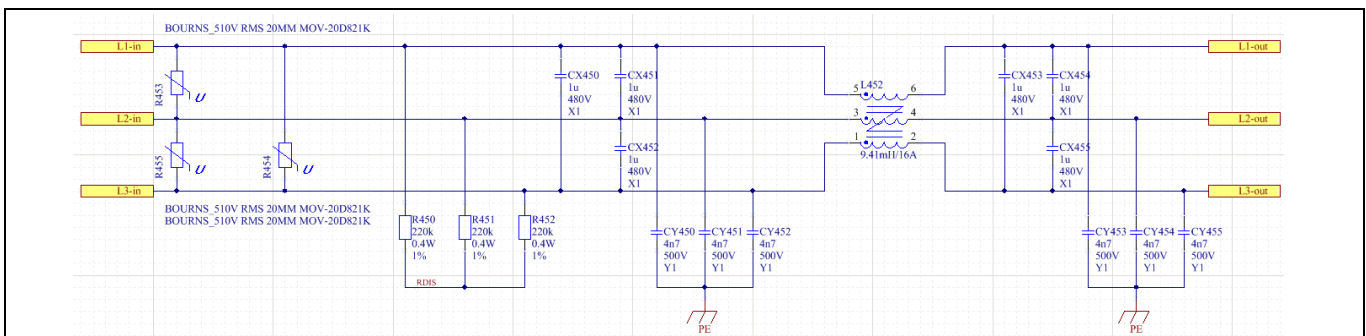

Figure 13 EMI Filter

The EMI filter is designed to minimize high-frequency emissions to the connected grid. Lower harmonics of the grid current are not suppressed! Additional mains line choke must be used to fulfill harmonic standards! In addition, a mains line choke also reduces the crest factor of the input current. Hence, an external choke allows higher RMS input currents leading to higher output power. Without an additional mains line choke an output power of approx. 6 kW can be achieved at 400 V line voltage.

However, the conducted EMI emission strongly depends on several operating conditions, like the connected motor, used switching frequency and so on. Consequently, the implemented filter not necessarily fulfill the required standard. If necessary a Vacuumschmelze W 424-53 ring core, or similar, with three turns can be added to the supply lines as a common mode choke to further reduce the conducted EMI.

5.3 Auxiliary Supply

All supply voltages are generated by a flyback converter, supplied from the DC-bus. It starts operation at a bus voltage of $477 V_{dc}$, which corresponds to approximately $340 V_{ac}$ input voltage. The supply circuit is realized with an Infineon ICE5QSAG control IC. To modify brownin voltage (e.g. to use 650 Voltage class devices) tune the

voltage divider (R668) according to ICE5QSAG datasheet. The supply voltages are isolated from the DC-bus potential by basic insulation. The complete schematic is shown in Figure 14.

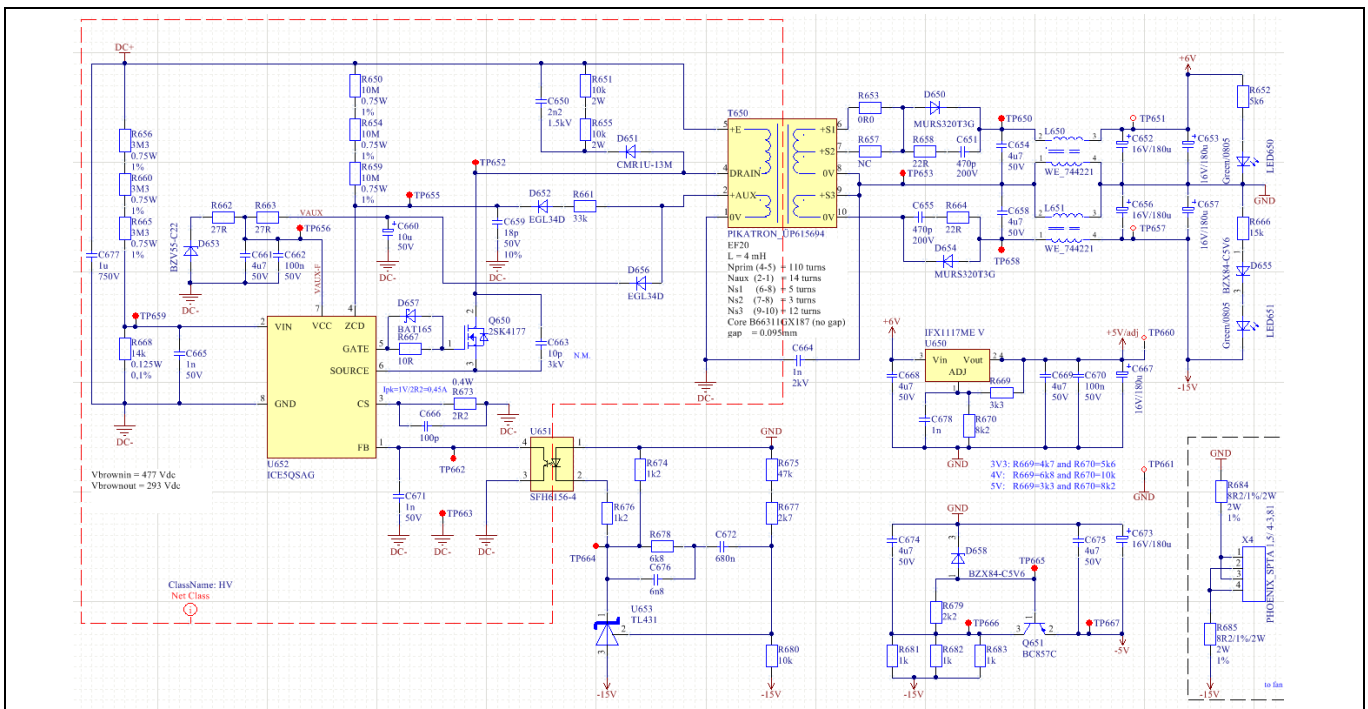

Figure 14 Auxiliary supply

The flyback converter generates three voltages. The auxiliary winding on the primary side of the transformer generates an unregulated 17.6 V supply for the control IC itself. On the transformer's secondary side two output voltages are generated: a regulated -15 V and indirect regulated +6 V. The -15 V supply voltage is mainly used for the IGBT driver supply circuit. From this voltage, a -5 V supply voltage is derived by a linear regulator used for the negative supply for the analog circuitry of the board. The positive analog supply is directly connected to the +6 V supply. This voltage rail is also used to generate the +5 V for the controller and overcurrent threshold generations.

If the EVAL-M5-IGBT7 is to be used with low DC-bus voltages below the brown in threshold of the flyback converter it is possible to supply it with an external power supply. Therefore, the test points TP651, TP656, and TP661 can be used. These test points are labeled with their corresponding voltage on the PCB. The points are depicted in Figure 15.

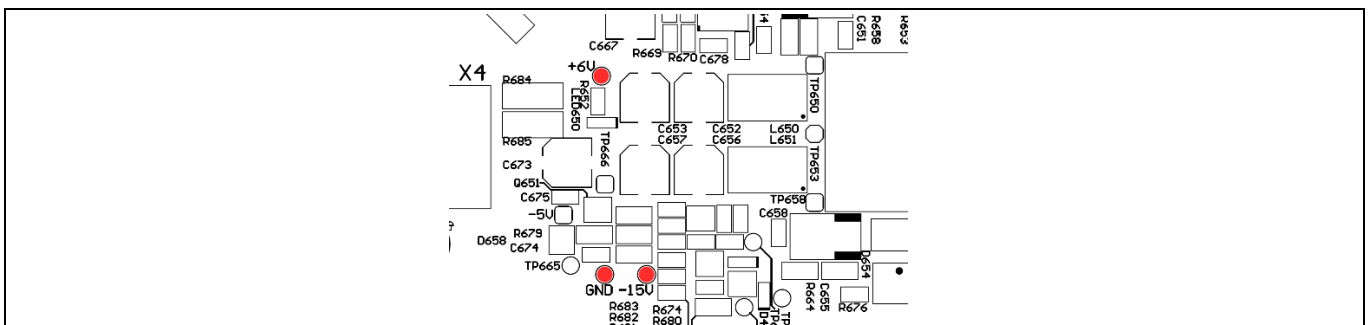

Figure 15 Major power supply test points

5.4 Power Stage

The schematic of the power stage is shown in Figure 16. The three-phase legs are connected to one film capacitor and four ceramic capacitors. Two of the ceramic capacitors are connected directly to the power switches prior to the current measuring shunt. For the film capacitors, two alternate packages can be mounted. Both high-frequency capacitor types are placed as close as possible to the power switches to minimize overvoltage at switching. Only two of the ceramic capacitors are connected prior to the shunt to limit short circuit energy. The DC-bus is led through to the connector X6.

The current measuring shunt is used to detect output short-circuits. An overcurrent protection circuit is used to monitor the shunt voltage and to disable all switches in an overcurrent condition.

At each phase, the output current is measured by a shunt resistor. The shunt voltages are measured by galvanic isolated DS-ADCs. Their supply is derived from an additional voltage level of the top-side driver supply circuit. The voltage of the DC-bus is measured by a voltage divider and the same isolated DS-ADC supplied from an additional driver voltage of the low-side driver supply. The functionalities of these blocks are explained below. An NTC can be mounted on the heatsink for generating a temperature-related measuring voltage V_{th} .

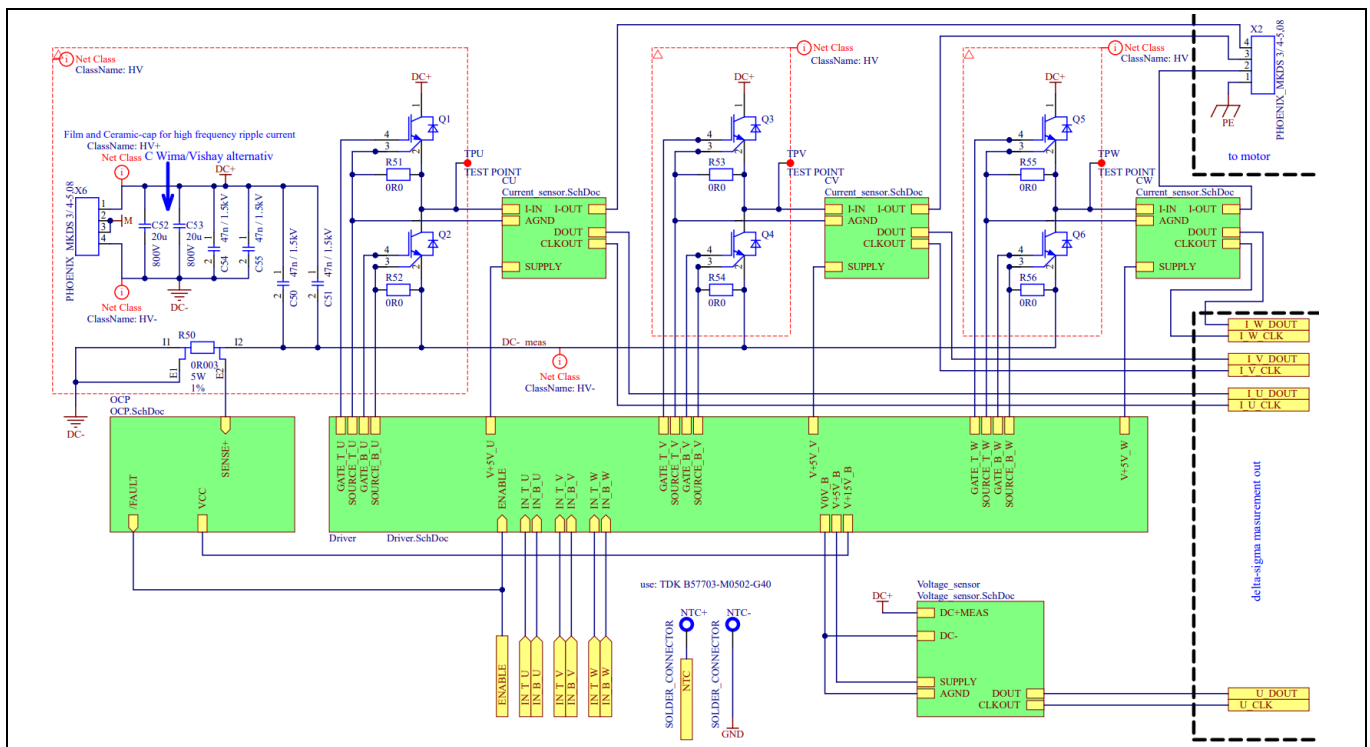

Figure 16 Power stage

5.5 Driver Circuit

Each of the six IGBTs is driven by Infineon’s IGBT EiceDRIVER™ 1EDI20H12AH. The positive input is protected by an additional glitch filter and a pull down resistor. All negative inputs are connected and are used for a global /ENABLE signal. The circuit, which is used for each phase leg, is shown in Figure 17.

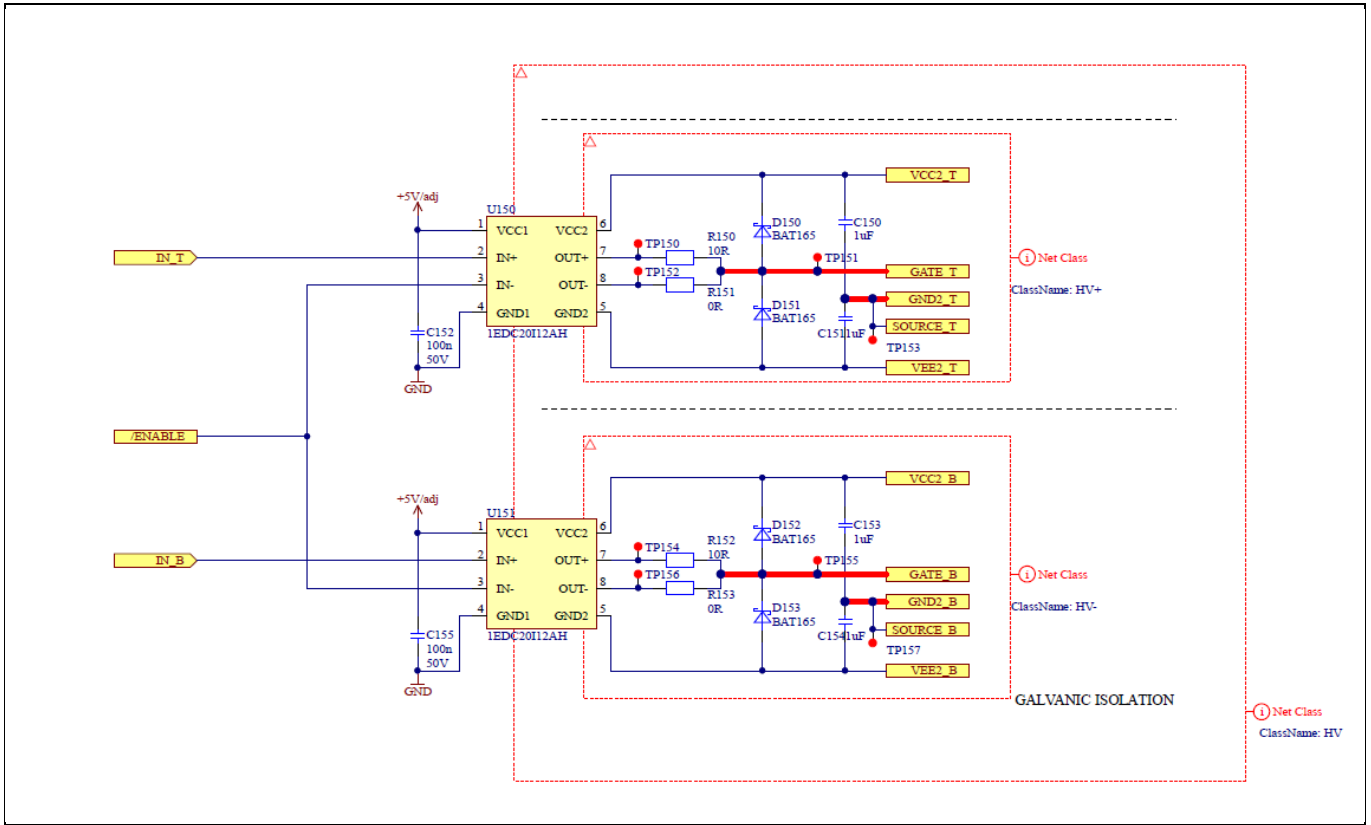

Figure 17 Driver circuit for one phase leg

The secondary sides of the EiceDRIVER™ are supplied by four galvanic isolated power supplies: one for each top-side driver including the current sensor supply and one for all low-side drivers together with the voltage sensor. The whole circuit is shown in Figure 18. The four output voltages are generated by two impulse transformers, which are supplied by a high-frequency oscillator. At each output, a rectifier is located which generates three different voltage levels.

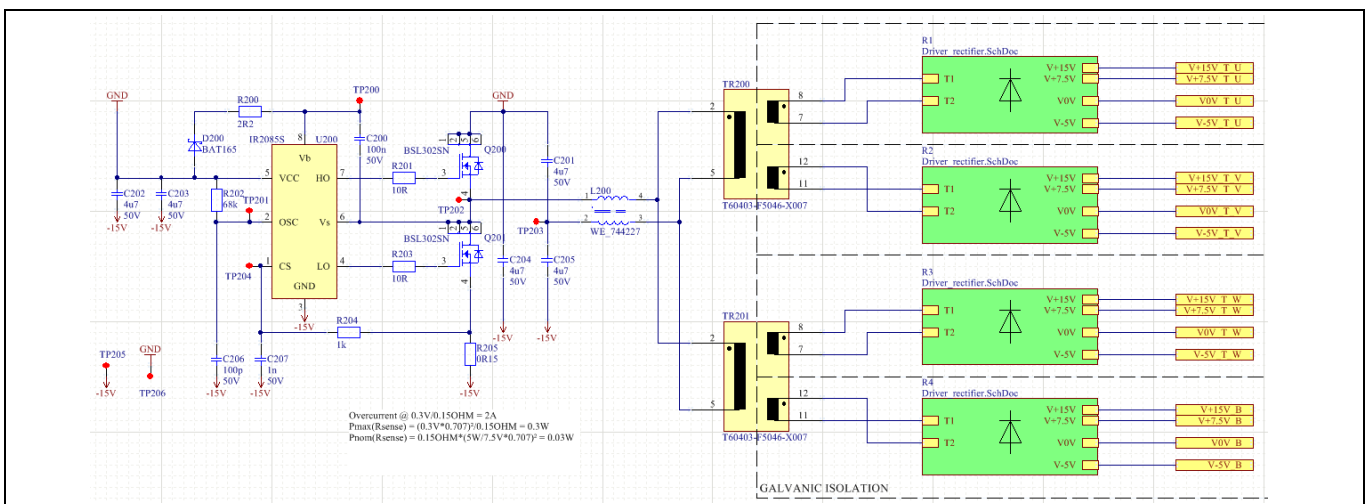

Figure 18 Driver power supply

The rectifier circuit generates three voltage levels for each driver: a regulated negative voltage for safe turning off the power IGBT, +15 V for turning on the power IGBT, and additionally +5 V for the additional current and voltage measurement. The circuit is shown in Figure 19.

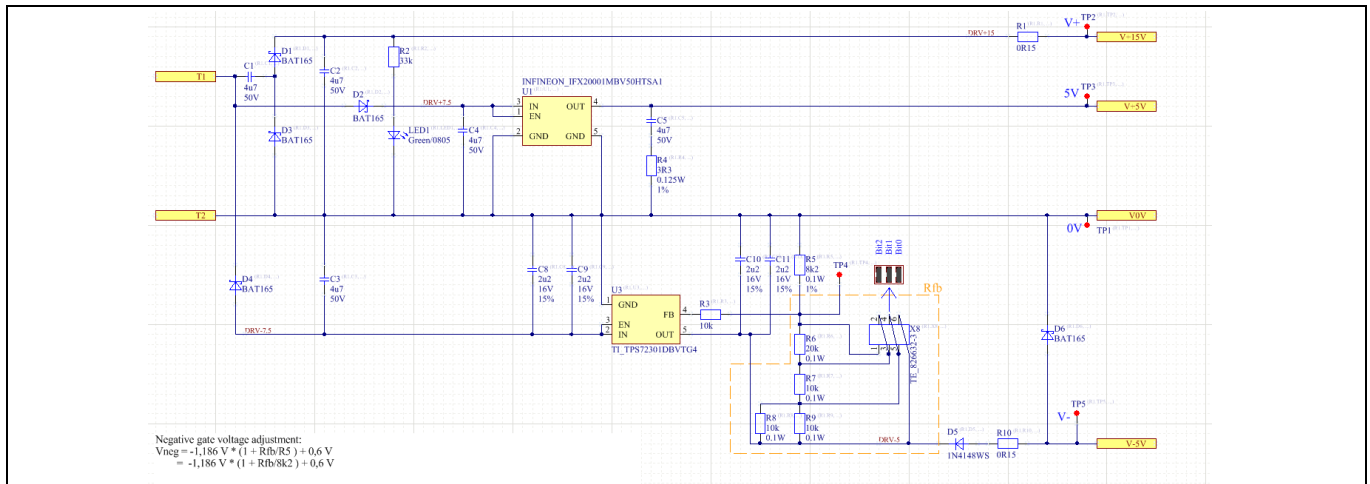

Figure 19 Rectifier circuit of driver power supply

The regulated negative voltage can be adjusted in 8 steps by placing jumpers on the pin header X8. This adjustment must be done for each rectifier circuit separately. By placing the jumpers the feedback resistor of the negative voltage regulator is changed. Consequently, its output voltage can be adjusted. The selectable voltages are shown in Table 10.

Additionally, it is possible to use real 0 V turn off voltage if R10 is removed and TP1 is connected to TP5. Be careful with adjusting the negative voltage! Load conditions might occur, which lead to undesired turn on of the power switches.

Table 10 X8 pin header negative gate voltage selection

Jumper setting	Negative gate voltage
	-5,6 V
	-4,9 V
	-4,2 V
	-3,5 V
	-2,8 V
	-2,0 V
	-1,3 V
	-0,6 V

5.6 Thermistor Output

The temperature of the heatsink is measured with a TDK B57703-M0502-G40 NTC resistor. The NTC resistor is connected to 5 V via a series resistor of 10 kΩ. The resulting NTC voltage is fed to the control board via an amplifier with a gain of 2. If necessary the signal level can be changed by exchanging the resistors R617, R620, R621, and R623. The evaluation circuit is depicted in Figure 20.

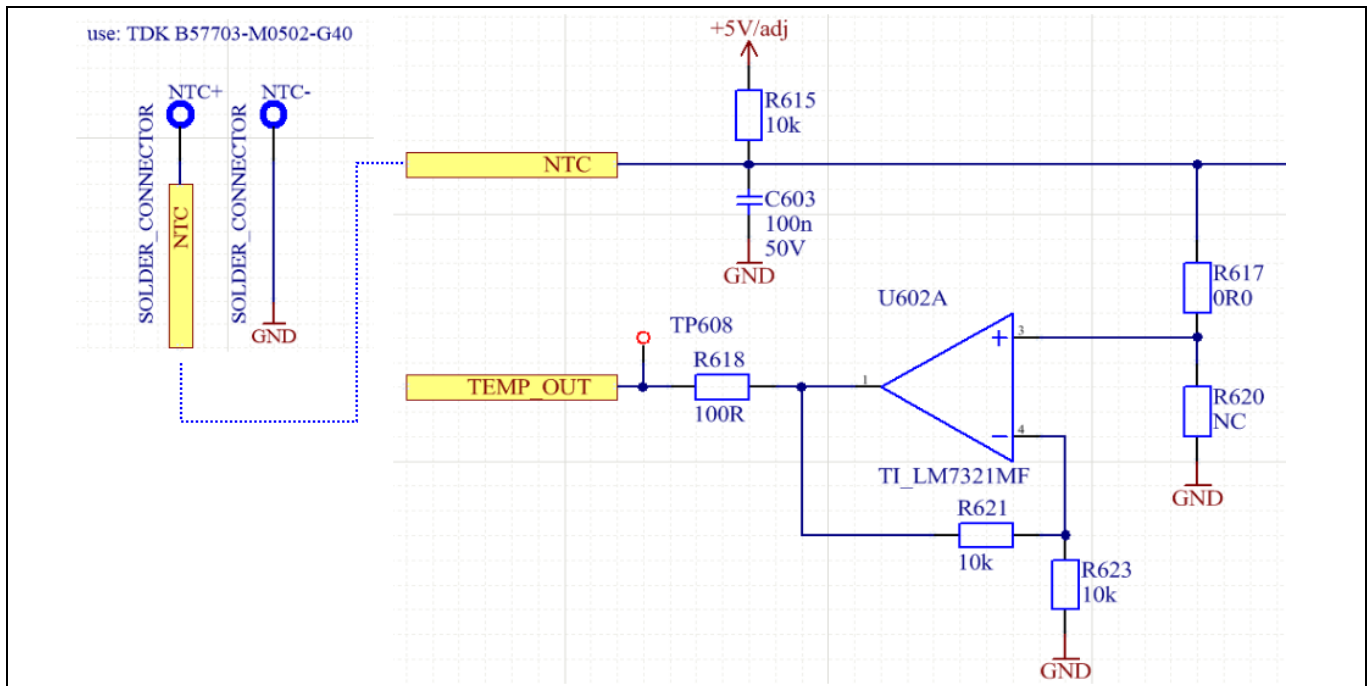

Figure 20 Evaluation circuit for NTC measurement

The dependency of the generated output voltage vs. the heatsink's temperature when using a TDK B57703-M0502-G40 NTC resistor is shown in Figure 21.

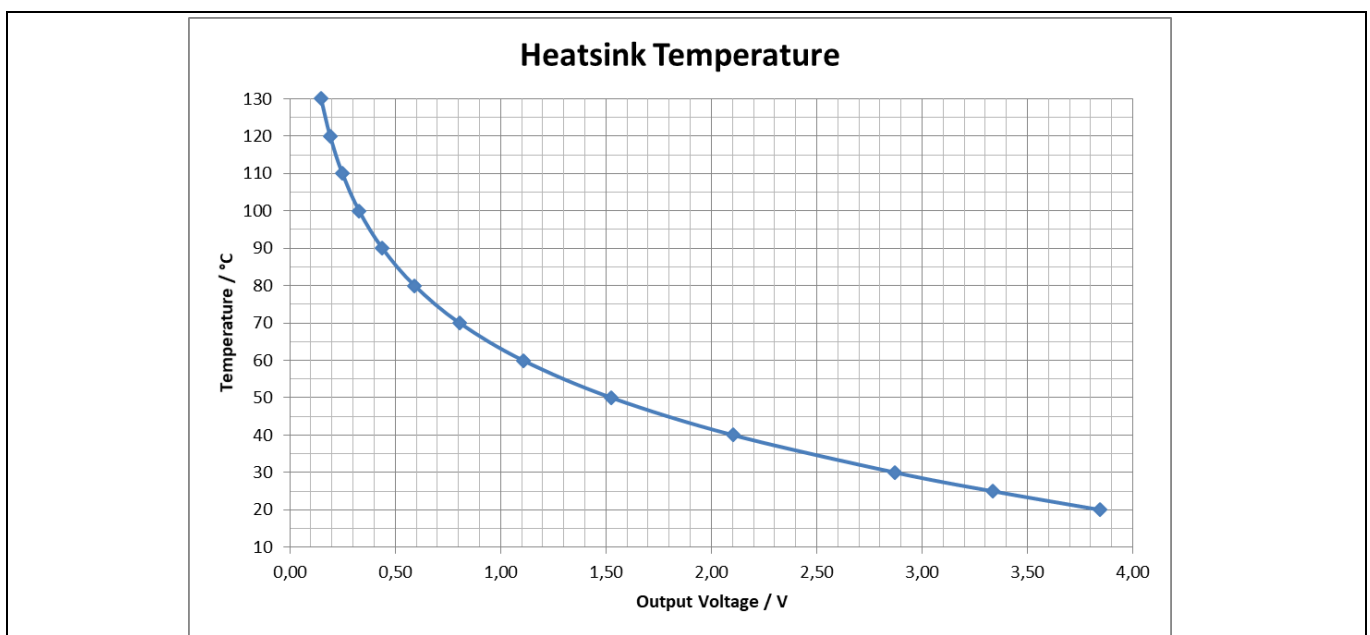

Figure 21 Heatsink temperature output

5.7 Current Measurement

The three phase currents are measured by shunt resistors. Each shunt voltage is measured by a galvanic isolated $\Delta\Sigma$ -modulator. The modulator generates a $\Delta\Sigma$ -modulated bit stream output with a clock frequency of 20 MHz. The circuit can be seen in Figure 22. The modulator is supplied via the +5 V output from the rectifier circuit.

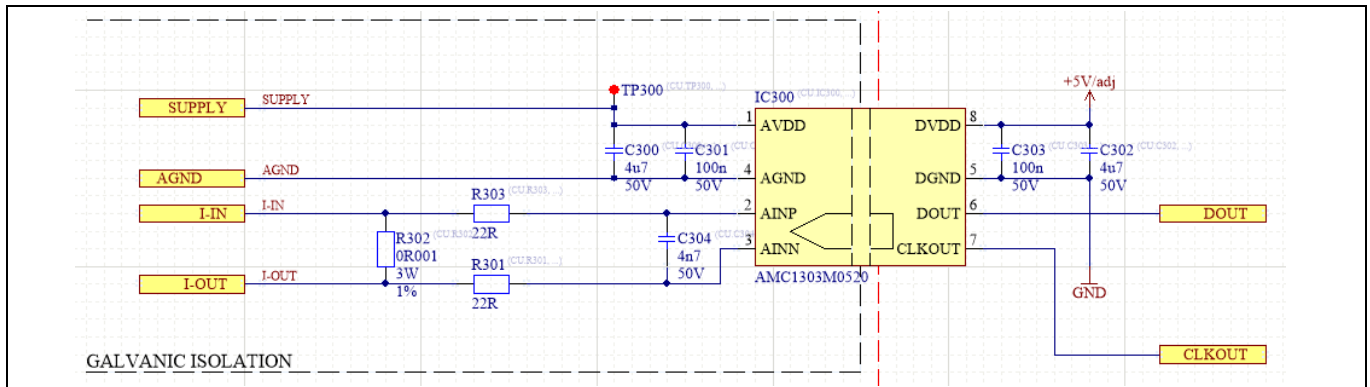

Figure 22 Phase current measurement

5.8 Voltage Measurement

Similar to the current measurement the DC-bus voltage is measured via a voltage divider and the galvanic isolated $\Delta\Sigma$ -modulator.

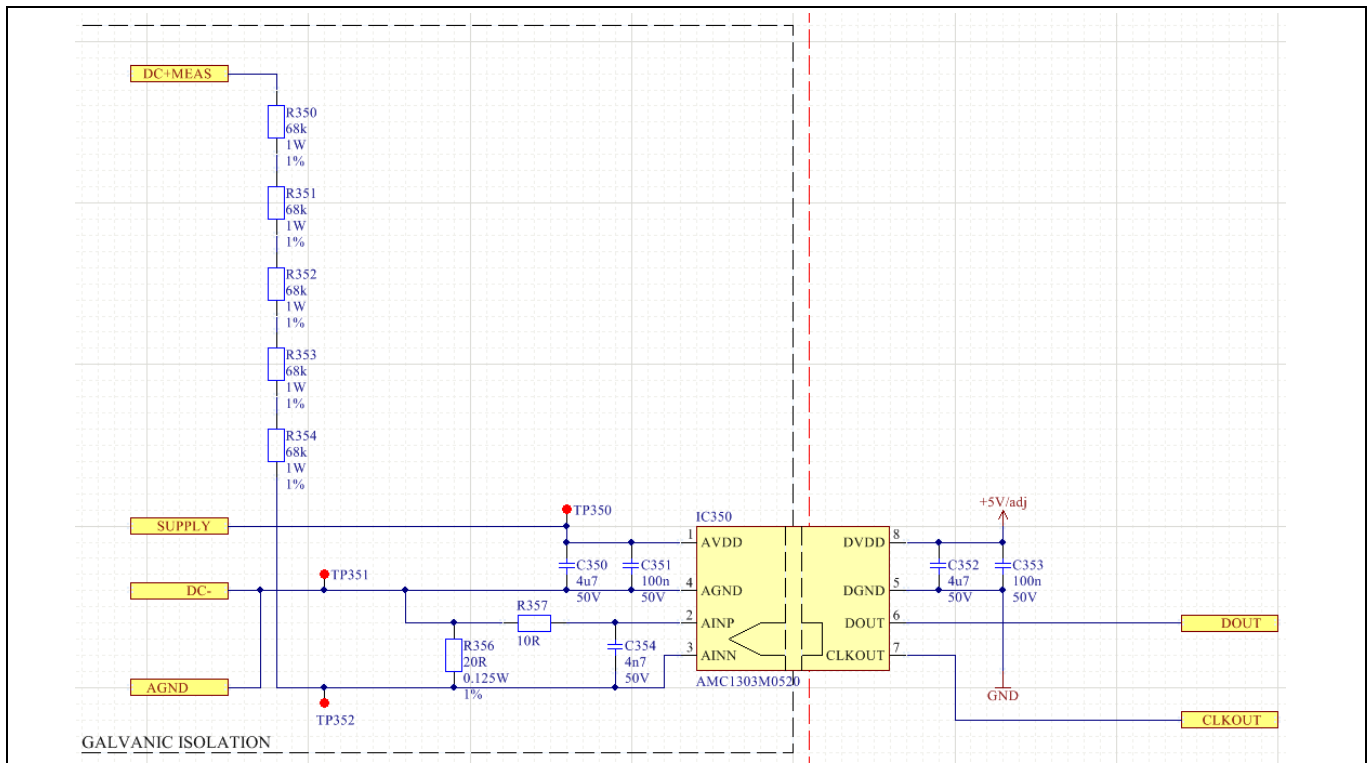

Figure 23 DC-bus voltage measurement

5.9 Analog to digital converter

The evaluation board contains four discrete analog to digital converters to generate analog signals from the digital $\Delta\Sigma$ -modulated bit streams. The analog signals are used for the on-board protection as well as for the external controller. The conversion is done by 2nd order low pass filters with approximately 6.5 kHz bandwidth. At zero input the $\Delta\Sigma$ -converter generates a bit stream with 50% duty cycle. For offset adjustment, the reference voltage of the low pass filters can be adjusted via the potentiometer R5564 for all three currents. The four $\Delta\Sigma$ -modulated bit streams can be measured directly at the pin headers X7.

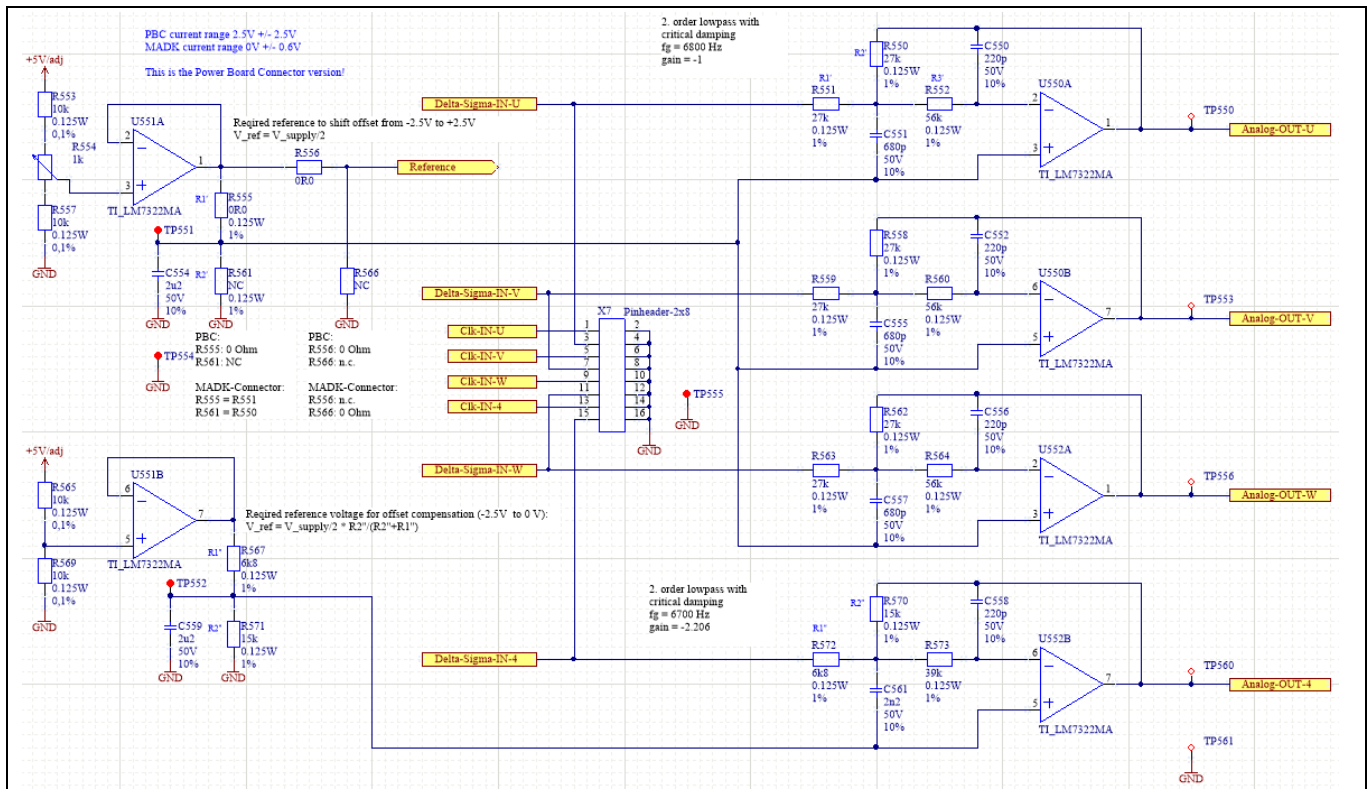

Figure 24 Measurement analog to digital conversion

5.10 Overload and Overtemperature Protection

The EVAL-M5-IGBT7 evaluation board is equipped with overcurrent and overtemperature protection. If an overcurrent or overtemperature event is detected the /FAULT signal is pulled low and the IGBT drivers are simultaneously disabled for around 30 ms.

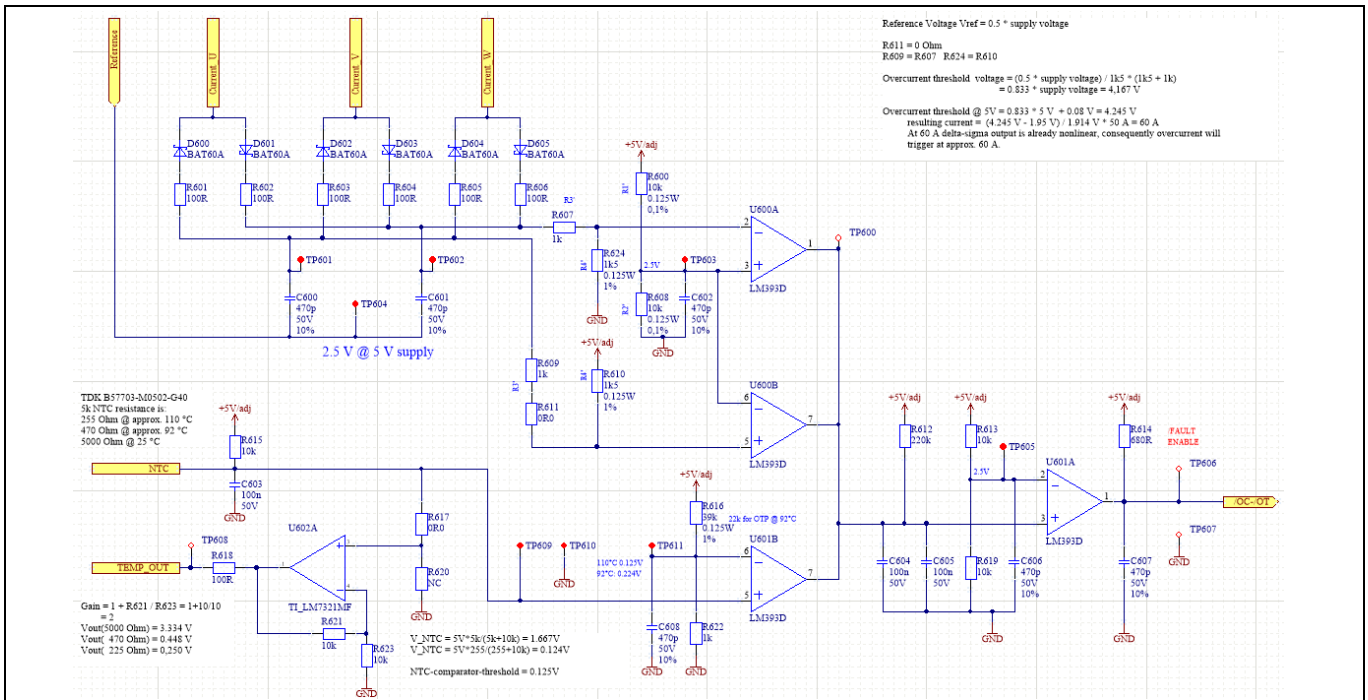

Figure 25 Protection circuit and temperature measurement

The overcurrent detection is realized with six ultra-low forward voltage drop diodes (D600 ... D605), which rectify the peak current of each phase. The peak positive value and the peak negative value are compared with a threshold value. If one is exceeded the /FAULT signal is triggered.

The overtemperature detection monitors directly the NTC voltage. A voltage below 0.125 V triggers the /FAULT signal. This threshold corresponds to a measured heatsink temperature of 110°C.

5.11 Overcurrent / Short Circuit Protection

The circuit, which monitors the voltage across a 3 mΩ shunt placed in the DC path of the power IGBT, is shown in Figure 26. A low side driver with an overcurrent protection feature is used here. The driver stage itself is unused. The Infineon 1ED44176N01F has 0.5 V overcurrent trigger threshold. This leads to a nominal current threshold of 167 A.

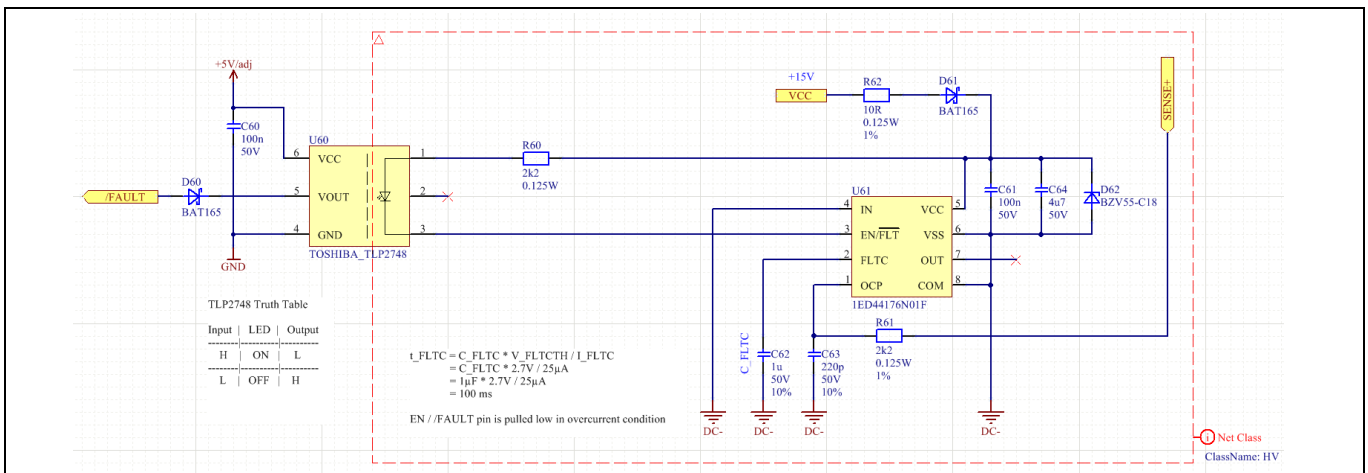

Figure 26 Short-circuit protection

Schematics and Layout

A low pass filter (R61/C63) is placed at the OCP pin of the IC. Its time constant of 484 ns is required to block high voltage spikes at fast current rises due to the parasitic inductance of the measuring shunt and its connection. If an overcurrent is detected the EN/FAULT pin of the driver is pulled low and the LED of the connected optocoupler turns on. Hence, the isolated side of the optocoupler turns low and the /FAULT signal is pulled low. Consequently, all IGBT drivers are turned off. The overall time delay from overcurrent to IGBT gate low is approximately 1 μ s.

The circuit is supplied via the low-side gate driver supply. This supply is referenced to the emitter of the low-side IGBTs which is before the shunt. Consequently, the supply of the OCP protection is decoupled with a diode (D61) and buffered with a capacitor (C64). This leads to a voltage drop of approximately 1 V in overcurrent condition but this is still sufficient to supply the circuit.

5.12 PCB Layout

The layout of this board is especially designed for evaluation purposes. Consequently, it has a lot of test points on it and is not necessarily suited for continuous operation at full load. The PCB has four electrical layers with 35 μ m copper. The size is 204 mm x 259 mm. The PCB thickness is 1.6 mm. Get in contact with our technical support team to get more detailed information of the layout design and the latest Gerber-files.

Measurements

6 Measurements

The following chapter shows some typical measurements made with the EVAL-M5-IGBT7 evaluation board with the IKW40N120CS7 device.

The board was supplied by a 400 V grid and it is connected at the output to a symmetrical RL – load illustrated in Figure 27.

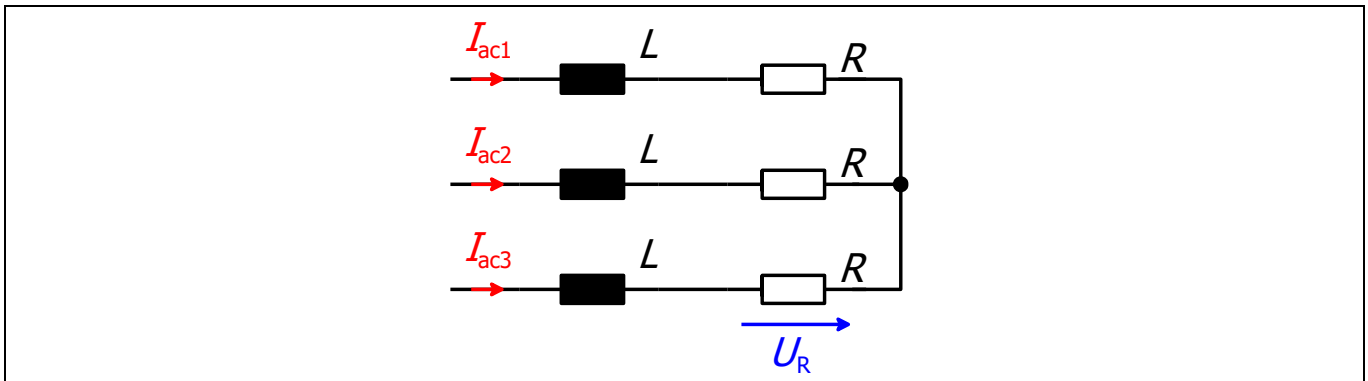

Figure 27 Test load

The value of the inductance is 1.5 mH and the value of the resistor is 30 Ω. With a nominal output current of 5 A_{RMS} the output power is about 2.3 kW. The switching frequency was set to 8 kHz and the dV/dt was reduced to max. 5 kV/μs with gate resistors of 27 Ω. The following figure 28 shows the related measurement.

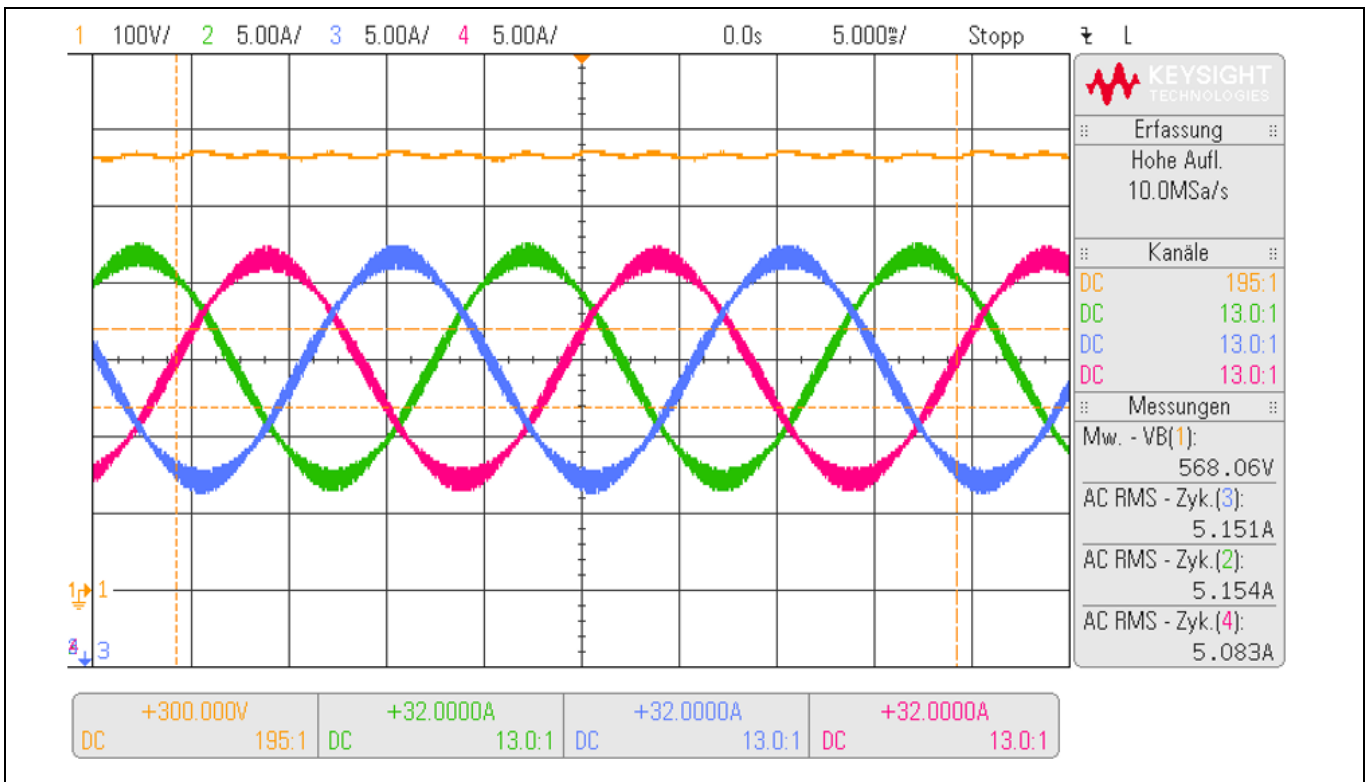

Figure 28 Measurement waveforms with test load (Ch1: DC-Bus voltage, Ch2 to Ch4: load currents)

Measurements

6.1 Thermal measurements

After the board was powered for around 10 minutes at this condition, the following thermal image was made.

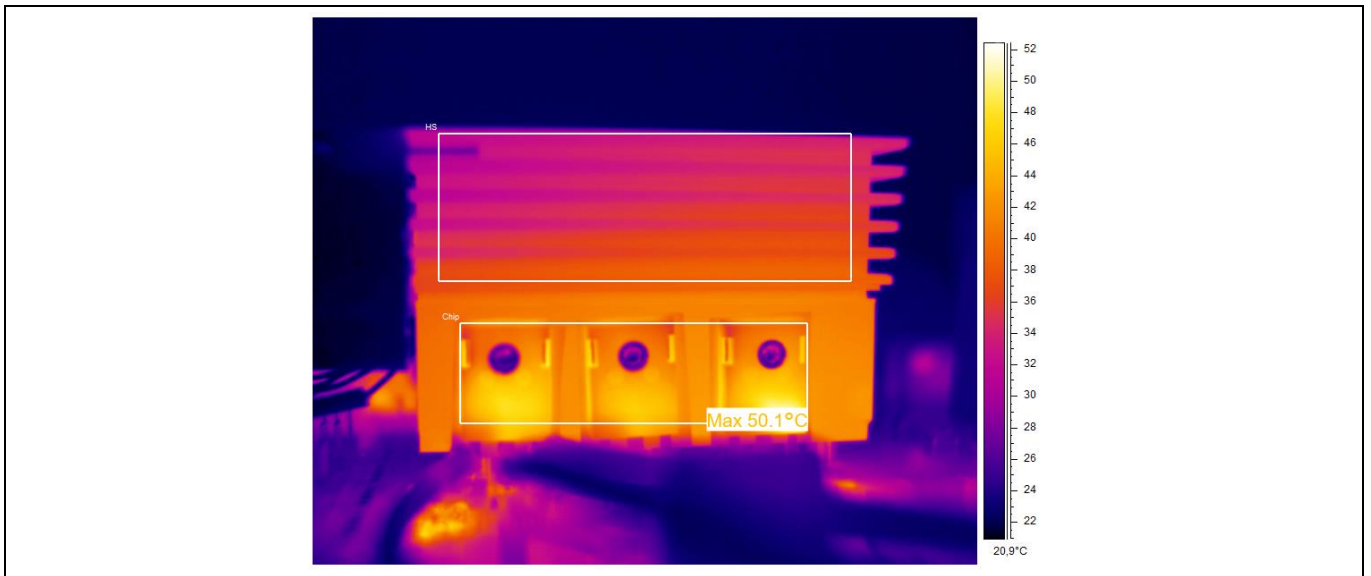

Figure 29 Thermal image the left power IGBTs with forced convection cooling

Bill of Material

7 Bill of Material

No	Qty	Part description	Designator	Part number	Manufacturer
	11	SCREW M3: ZYK ISK / 8mm / ST8,8 vz bp	SCREW1, SCREW2, SCREW3		no special
1	1	NUT: M3 / ST 8 vz bp	NUT1, NUT2, NUT3, NUT4, NUT5, NUT6, NUT7, NUT8, NUT9		no special
2	4	WASHER: 3,2mm / ST vz bp	WASHER1, WASHER2		no special
3	2	SPACER BOLT: M3 / M3 / 12mm / STvz / SW 5,5mm / Freistich	SPACER1, SPACER2, SPACER3, SPACER4, SPACER5, SPACER6, SPACER7, SPACER8, SPACER9	05.13.121	ETTINGER GmbH
4	2	DIODE ZENER: BZV55-C18	D62	BZV55-C18	no special
5	1	DIODE ZENER: BZV55-B22	D653	BZV55-B22	no special
6	2	DIODE ZENER: BZX84-C5V6	D655, D658	BZX84-C5V6	no special
7	1	DIODE SCHOTTKY: BAT165	D60, D61, D100, D101, D200, D400, D657, R1.D1, R1.D2, R1.D3, R1.D4, R1.D6, R2.D1, R2.D2, R2.D3, R2.D4, R2.D6, R3.D1, R3.D2, R3.D3, R3.D4, R3.D6, R4.D1, R4.D2, R4.D3, R4.D4, R4.D6	BAT165	Infineon
8	11	DIODE SCHOTTKY: BAT60A	D600, D601, D602, D603, D604, D605	BAT60AE6327HTSA1	Infineon
9	4	DIODE STANDARD: MURS320T3G	D650, D654	MURS320T3G	ON Semiconductor
10	1	DIODE STANDARD: CMR1U-13M	D651	CMR1U-13M	Central Semiconductor Corp.
11	1	DIODE STANDARD: EGL34D-E3	D652, D656	EGL34D-E3	Vishay
12	2	DIODE STANDARD: 1N4148WS	R1.D5, R2.D5, R3.D5, R4.D5	1N4148WS	no special
13	27	RECT BRIDGE: SBR2512W	GL400	SBR2512W	Multicomp
14	6	IC ADC: AMC1303M0520	CU.IC300, CV.IC300, CW.IC300, IC350	AMC1303M0520	Texas Instruments
15	4	IC OPAMP: LM7322MA	U550, U551, U552	LM7322MA	Texas Instruments
16	2	IC OPAMP: LM7321MF	U602	LM7321MF	Texas Instruments
17	1	IC DRIVER: 1ED44176N01F	U61	1ED44176N01F	Infineon
18	2	IC DRIVER: IR2085	U200	IR2085S	Infineon

Bill of Material

19	1	IC DRIVER: 1EDI20H12AH	U.U150, U.U151, V.U150, V.U151, W.U150, W.U151	1EDI20H12AH	Infineon
20	4	IC VOLT REG: IFX20001MBV50HTSA1	R1.U1, R2.U1, R3.U1, R4.U1	IFX20001MBV50HTS A1	Infineon
21	3	IC VOLT REG: TPS72301DBVTG4	R1.U3, R2.U3, R3.U3, R4.U3	TPS72301DBVTG4	Texas Instruments
22	1	IC VOLT REG: IFX1117ME V	U650	IFX1117ME V	Infineon
23	1	IC VOLT REG: ICE5QSAG	U652	ICE5QSAG	Infineon
24	6	IC VOLT REG: TL431AFDT	U653	TL431AFDT	NXP
25	1	IC COMP: LM393D	U600, U601	LM393D	Texas Instruments
26	1	IC LOGIC: 74HCT7541D	U20	74HCT7541D	NXP
27	1	IC OPTOCOUPLE: TLP2748	U60	TLP2748	Toshiba
28	1	IC OPTOCOUPLE: SFH6156-4T	U651	SFH6156-4T	Vishay
29	4	LED: 0805 / green	LED10, LED650, LED651, R1.LED1, R2.LED1, R3.LED1, R4.LED1	SMD-G0805-02	Sloan AG
30	4	TRANS NPN: BC847C	Q10, Q100, Q400	BC847C	Infineon
31	2	TRANS PNP: BC857C	Q651	BC857C	Infineon
32	1	IGBT: BSL302SN	Q200, Q201	BSL302SN	Infineon
33	1	IGBT: 2SK4177	Q650	2SK4177	ON Semiconductor
34		POWER IGBT	Q1, Q2, Q3, Q4, Q5, Q6		Infineon
35	1	RES SMD 0805: 22R / 1% / 0,125W	CU.R301, CU.R303, CV.R301, CV.R303, CW.R301, CW.R303		no special
36	7	RES SMD 0805: 0R15 / 1% / 0,125W	R1.R1, R1.R10, R2.R1, R2.R10, R3.R1, R3.R10, R4.R1, R4.R10, R205		no special
37	3	RES SMD 0805: 33k / 1% / 0,125W	R1.R2, R2.R2, R3.R2, R4.R2, R661		no special
38	1	RES SMD 0805: 3R3 / 1% / 0,125W	R1.R4, R2.R4, R3.R4, R4.R4		no special
39	2	RES SMD 0805: 0R0 / 1% / 0,125W	R11, R51, R52, R53, R54, R55, R56, R555, R556, R611, R617, R653		no special
40	1	RES SMD 0805: 2k7 / 1% / 0,125W	R15, R677		no special
41	1	RES SMD 0805: 1k0 / 1% / 0,125W	R16, R100, R204, R607, R609, R622		no special

Bill of Material

42	6	RES SMD 0805: 4k7 / 1% / 0,125W	R17		no special
43	1	RES SMD 0805: 2k2 / 1% / 0,125W	R60, R61		no special
44	4	RES SMD 0805: 10R / 1% / 0,125W	R62, R101, R201, R203, R357, R667, U.R152, U.R158, V.R152, V.R158, W.R152, W.R158		no special
45	24	RES SMD 0805: 10k / 1% / 0,125W	R102, R613, R615, R619, R621, R623, R680, U.R153, U.R159, V.R153, V.R159, W.R153, W.R159		no special
46	1	RES SMD 0805: 2R2 / 1% / 0,125W	R200		no special
47	6	RES SMD 0805: 68k / 1% / 0,125W	R202		no special
48	2	RES SMD 0805: 20R / 1% / 0,125W	R356		no special
49	11	RES SMD 0805: 3k3 / 1% / 0,125W	R405, R669		no special
50	1	RES SMD 0805: 100R / 1% / 0,125W	R500, R501, R502, R503, R601, R602, R603, R604, R605, R606, R618		no special
51	6	RES SMD 0805: 27k / 1% / 0,125W	R550, R551, R558, R559, R562, R563		no special
52	2	RES SMD 0805: 56k / 1% / 0,125W	R552, R560, R564		no special
53	2	RES SMD 0805: 10k / 0,1% / 0,125W	R553, R557, R565, R569, R600, R608		no special
54	1	RES SMD 0805: 6k8 / 1% / 0,125W	R567, R572, R678		no special
55	2	RES SMD 0805: 15k / 1% / 0,125W	R570, R571, R666		no special
56	2	RES SMD 0805: 39k / 1% / 0,125W	R573, R616		no special
57	2	RES SMD 0805: 1k5 / 1% / 0,125W	R610, R624		no special
58	3	RES SMD 0805: 220k / 1% / 0,125W	R612		no special
59	1	RES SMD 0805: 680R / 1% / 0,125W	R614		no special
60	1	RES SMD 0805: 5k6 / 1% / 0,125W	R652		no special
61	13	RES SMD 0805: 27R / 1% / 0,125W	R662, R663		no special
62	2	RES SMD 0805: 14k / 0,1% / 0,125W	R668		no special
63	1	RES SMD 0805: 8k2 / 1% / 0,125W	R670		no special
64	1	RES SMD 0805: 1k2 / 1% / 0,125W	R674, R676		no special
65	6	RES SMD 0805: 47k / 1% / 0,125W	R675		no special

Bill of Material

66	5	RES SMD 0805: 33R / 1% / 0,125W	U.R150, U.R151, U.R156, U.R157, V.R150, V.R151, V.R156, V.R157, W.R150, W.R151, W.R156, W.R157		no special
67	1	RES SMD 1206: 82R / 1% / 0,25W	R404		no special
68	1	RES SMD 1206: 22R / 1% / 0,25W	R658, R664		no special
69	3	RES SMD 1206: 2k2 / 1% / 0,25W	R679		no special
70	1	RES SMD 1206: 1k0 / 1% / 0,25W	R681, R682, R683		no special
71	1	RES SMD Melf: 2R2 / 1% / 0,4W	R673		no special
72	6	RES THT: PO591-0 5T 56K	R400, R401	PO591-0 5T 56K	VITROHM
73	1	VARISTOR: 510V RMS 20MM MOV-20D821K	R453, R454, R455	MOV-20D821K	Bourns
74	9	NTC: SL32 5R020	R402, R403	SL32 5R020	Ametherm
75	2	NTC: B57703-M0502-G40	THERMISTOR1	B57703M0502G040	TDK ehem. Epcos
76	1	RES VAR: 1k / 250mW / SMD	R554	23BR1KLFTR	BI Technologies
77	3	RES SMD 2512: 0R001 / 1% / 3W	CU.R302, CV.R302, CW.R302	CRE2512-FZ-R001E-3	Bourns
78	1	RES SMD 2512: 0R0 / 1W	R12, R13, R14		no special
79	1	RES SMD 2512: 68k / 1% / 1W	R350, R351, R352, R353, R354		no special
80	2	RES SMD 2512: 220k / 1% / 2W	R450, R451, R452		no special
81	3	RES SMD 2512: 10k / 1% / 1W	R651, R655		no special
82	2	RES SMD 2512: TE_8R2 / 1% / 3W	R684, R685	35228R2JT	TE Connectivity
83	1	RES SMD 0603: 10k / 1% / 0,1W	R1.R3, R1.R7, R1.R8, R1.R9, R2.R3, R2.R7, R2.R8, R2.R9, R3.R3, R3.R7, R3.R8, R3.R9, R4.R3, R4.R7, R4.R8, R4.R9, R20, R21, R22, R23, R24, R25		no special
84	5	RES SMD 0603: 8k2 / 1% / 0,1W	R1.R5, R2.R5, R3.R5, R4.R5		no special

Bill of Material

85	3	RES SMD 0603: 20k / 1% / 0,1W	R1.R6, R2.R6, R3.R6, R4.R6		no special
86	2	RES SMD 2010: 10M / 1% / 0,75W	R650, R654, R659		no special
87	2	RES SMD 2010: 3M3 / 5% / 0,75W	R656, R660, R665		no special
88	3	RES SMD special: 0R003 / 1% / 5W	R50	CSS2H-3920K-3L00F	no special
89	3	CAP CER 0805: 100n / 50V / X7R	C20, C60, C61, C200, C351, C353, C563, C564, C565, C603, C604, C605, C610, C611, C612, C613, C662, C670, CU.C301, CU.C303, CV.C301, CV.C303, CW.C301, CW.C303, U.C152, U.C157, V.C152, V.C157, W.C152, W.C157		no special
90	4	CAP CER 0805: 1u0 / 50V / X7R	C62		no special
91	22	CAP CER 0805: 220p / 50V / X7R	C63, C550, C552, C556, C558		no special
92	4	CAP CER 0805: 4u7 / 35V / X5R	C64, C201, C202, C203, C204, C205, C350, C352, C405, C406, C562, C609, C654, C658, C661, C668, C669, C674, C675, CU.C300, CU.C302, CV.C300, CV.C302, CW.C300, CW.C302, R1.C1, R1.C2, R1.C3, R1.C4, R1.C5, R2.C1, R2.C2, R2.C3, R2.C4, R2.C5, R3.C1, R3.C2, R3.C3, R3.C4, R3.C5, R4.C1, R4.C2, R4.C3, R4.C4, R4.C5, U.C151, U.C153, U.C156, U.C158, V.C151, V.C153, V.C156, V.C158, W.C151, W.C153, W.C156, W.C158		no special
93	3	CAP CER 0805: 47p / 50V / X7R	C100		no special
94	3	CAP CER 0805: 100p / 50V / X7R	C206, C666, U.C150, U.C155, V.C150, V.C155, W.C150, W.C155		no special
95	1	CAP CER 0805: 1n0 / 50V / X7R	C207, C665, C671, C678		no special
96	1	CAP CER 0805: 4n7 / 50V / X7R	C354, CU.C304, CV.C304, CW.C304		no special
97	8	CAP CER 0805: 10n / 50V / X7R	C500, C501, C502, C503		no special
98	5	CAP CER 0805: 680p / 50V / X7R	C551, C555, C557		no special
99	6	CAP CER 0805: 2u2 / 50V / X7R	C554, C559		no special
100	3	CAP CER 0805: 2n2 / 50V / X7R	C561		no special

Bill of Material

101	4	CAP CER 0805: 470p / 50V / X7R	C600, C601, C602, C606, C607, C608		no special
102	1	CAP CER 0805: 18p / 50V / X7R	C659		no special
103	4	CAP CER 0805: 680n / 50V / X7R	C672		no special
104	1	CAP CER 0805: 6n8 / 50V / X7R	C676		no special
105	4	CAP CER 0805: 3n3 / 50V / X7R	U.C154, U.C159, V.C154, V.C159, W.C154, W.C159		no special
106	30	CAP CER 1206: 470p / 200V / X7R	C651, C655		no special
107	1	CAP CER: 47n / 1,5kV / X7R	C50, C51, C54, C55	2220SC473KAT1A	AVX
108	1	CAP CER: VY1472M61Y5UC63V0	CY450, CY451, CY452, CY453, CY454, CY455	VY1472M61Y5UC63V0	Vishay
109	2	CAP FILM: MKP 20u 800VDC DC-Link 4Pin	C52	DCP4L052007GD4K* SD	WIMA
110	57	CAP FILM: B32674D1105K000	C402, C677	B32674D1105K000	TDK ehem. Epcos
111	1	CAP FILM: B32021A3222M189	C650	B32021A3222M189	TDK ehem. Epcos
112	2	CAP FILM: B32021A3102M	C664	B32021A3102M289	TDK ehem. Epcos
113	6	CAP FILM: 1u / 480V / X1	CX450, CX451, CX452, CX453, CX454, CX455	F339X151048KKI2B0	Vishay
114	4	CAP ALUM: B43630A9128M000	C400, C401, C403, C404	B43630A9128M000	TDK ehem. Epcos
115	1	CAP ALUM: 16SVPF180M	C652, C653, C656, C657, C667, C673	16SVPF180M	Panasonic
116	1	CAP ALUM: NACZ100M50V6,3X6,3	C660	NACZ100M50V6.3X6.3	NIC Components
117	6	CAP CER 0603: 2u2 / 16V / X5R	R1.C8, R1.C9, R1.C10, R1.C11, R2.C8, R2.C9, R2.C10, R2.C11, R3.C8, R3.C9, R3.C10, R3.C11, R4.C8, R4.C9, R4.C10, R4.C11		no special
118	1	IND CM MODE: 744227	L200	744227	Würth Elektronik
119	2	IND CM MODE: T60405-S6123-X317	L452	T60405-S6123-X317	VACUUMSCHMELZ E
120	1	IND CM MODE: 744221	L650, L651	744221	Würth Elektronik
121	6	TRANSFORMER: T60403-F5046-X007 Pulstrafo	TR200, TR201	T60403-F5046-X007	VACUUMSCHMELZ E
122	4	FUSE: D6,3x32mm / 16A	F400, F401, F402		no special
123	16	FUSE CLIP: 8040.0001	X401, X402, X403, X404, X405, X406	80.400.001	Schurter
124	1	RELAY: RTS3L012	K400	1-1415898-9	TE Connectivity / Schrack

Bill of Material

125	2	CON MULTIPOLE: 2x16	X10	09 27 232 6801	Harting
126	1	CON: pinheader 2x3	R1.X8, R2.X8, R3.X8, R4.X8, X11	826632-3	TE Connectivity
127	2	CON: pin header 2x8	X7	TSM-108-01-T-DV	Samtec
128	3	CON TERM BLOCK: MKDS 3/ 4-5,08	X1, X2, X6	1712805	PHOENIX CONTACT
129	6	CON TERM BLOCK: SPTA 1,5/ 4-3,81	X4	1751493	PHOENIX CONTACT
130	1	TRANSFORMER: Flyback	T650	ÜP615694	Pikatron GmbH
131	1	HEATSINK: ICK S 29 x 29 x 30	HS2	ICK S 29 x 29 x 30	Fischer Elektronik
132	5	HEATSINK: SK 641/84 SA	HS1	SK 641 84 SA	Fischer Elektronik
133	1	HEATSINK CLIP: THFU3	TRANSISTOR_CLIP_1, TRANSISTOR_CLIP_2, TRANSISTOR_CLIP_3, TRANSISTOR_CLIP_4, TRANSISTOR_CLIP_5, TRANSISTOR_CLIP_6	THFU 3	Fischer Elektronik
134	3	HEATSINK ISO: Keramik / TO218/247/248 / ohne Loch	TRANSISTOR_ISO_1, TRANSISTOR_ISO_2, TRANSISTOR_ISO_3, TRANSISTOR_ISO_4, TRANSISTOR_ISO_5, TRANSISTOR_ISO_6	AOS 247	Fischer Elektronik
135	11	SCREW M3: ZYK ISK / 8mm / ST8,8 vz bp	SCREW1, SCREW2, SCREW3		no special

- [1] Datasheet of compatible Infineon IGBTs
- [2] Datasheet of Infineon EiceDRIVER™ 1EDI20H12AH
- [3] Datasheet of Texas Instruments isolated $\Delta\Sigma$ -Modulator AMC1303M2520

Revision history

Document version	Date of release	Description of changes