

Austin TLynx™ Series Evaluation Board Documentation

There are three Austin TLynx™ series evaluation boards. One board has a dual layout of the Austin PicoTLynx™ and the Austin MicroTLynx™ / ProLynx™ modules, the second has a dual layout of the Austin MicroTLynx™/ ProLynx™ and the Austin TLynx™/MegaTLynx™ modules and the third has a single layout of the GigaTLynx modules. Note that the boards come with a module already assembled on to the board. The specific combination of module and board desired can be ordered using the list available from your sales representative.

The dual layouts on each board also serve as example layouts for applications where dual layouts may be desirable, e.g. when the output current is uncertain and there is an advantage in either adding a higher power or lower power capability through a dual layout.

1. Schematics

Figures 1 and 2 show schematics of the PicoTLynx/MicroTLynx/ProLynx and MicroTLynx/ProLynx/TLynx/MegaTLynx evaluation boards. Figure 3 shows the Giga TLynx board

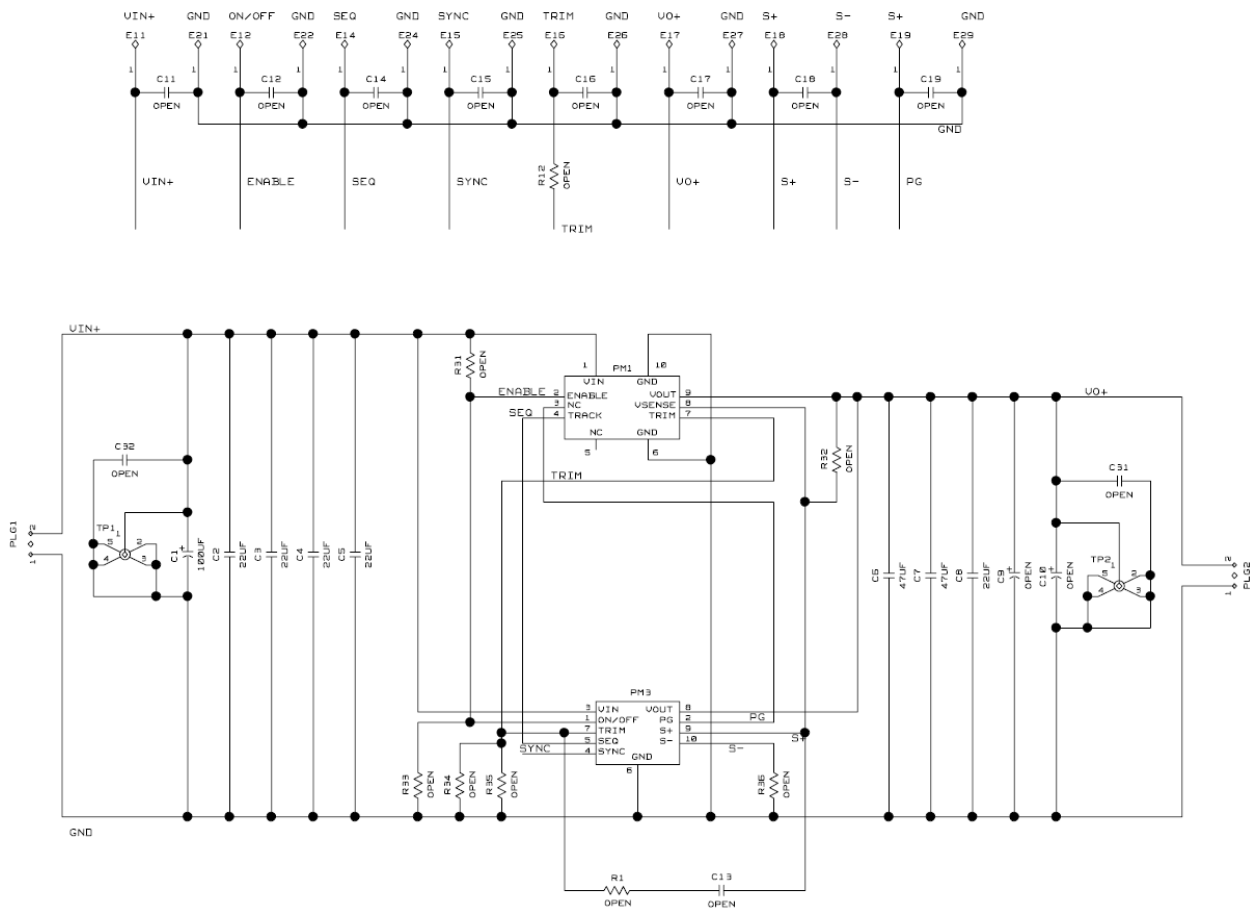

Figure 1. Schematic of the PicoTLynx/MicroTLynx/ProLynx Evaluation board.

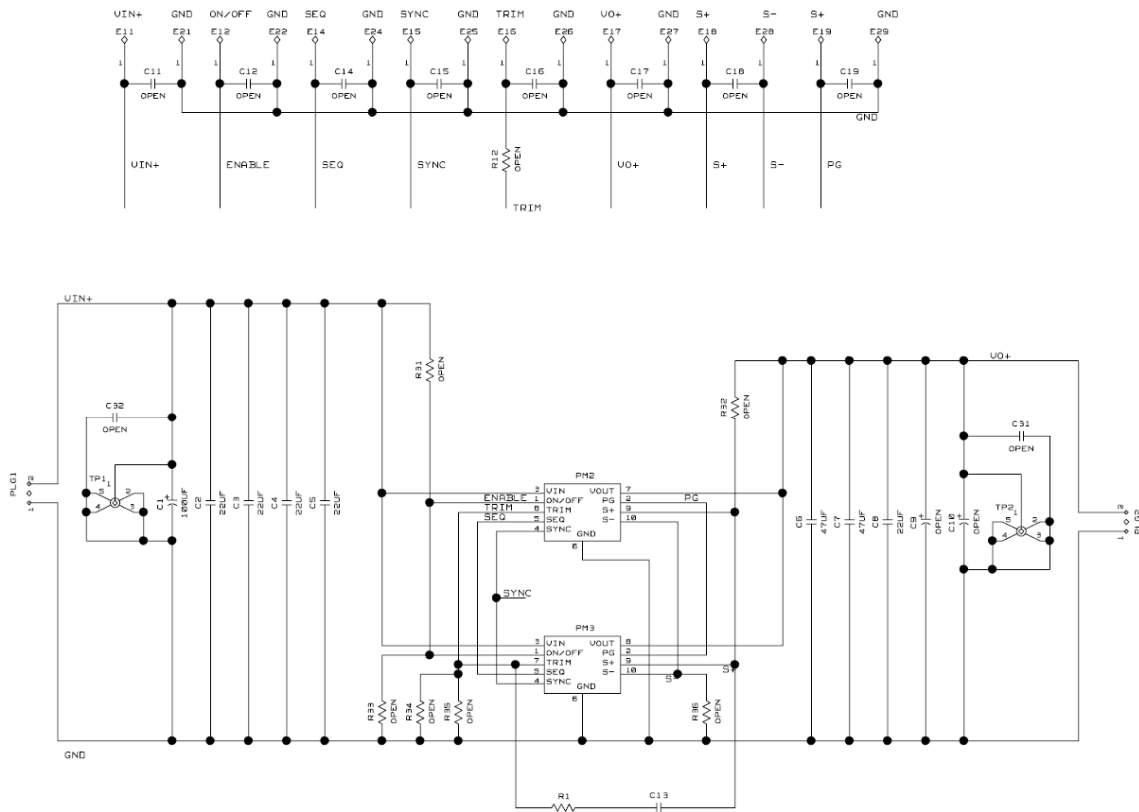

Figure 2. Schematic of the MicroTLynx/ProLynx/TLynx/MegaTLynx Evaluation board.

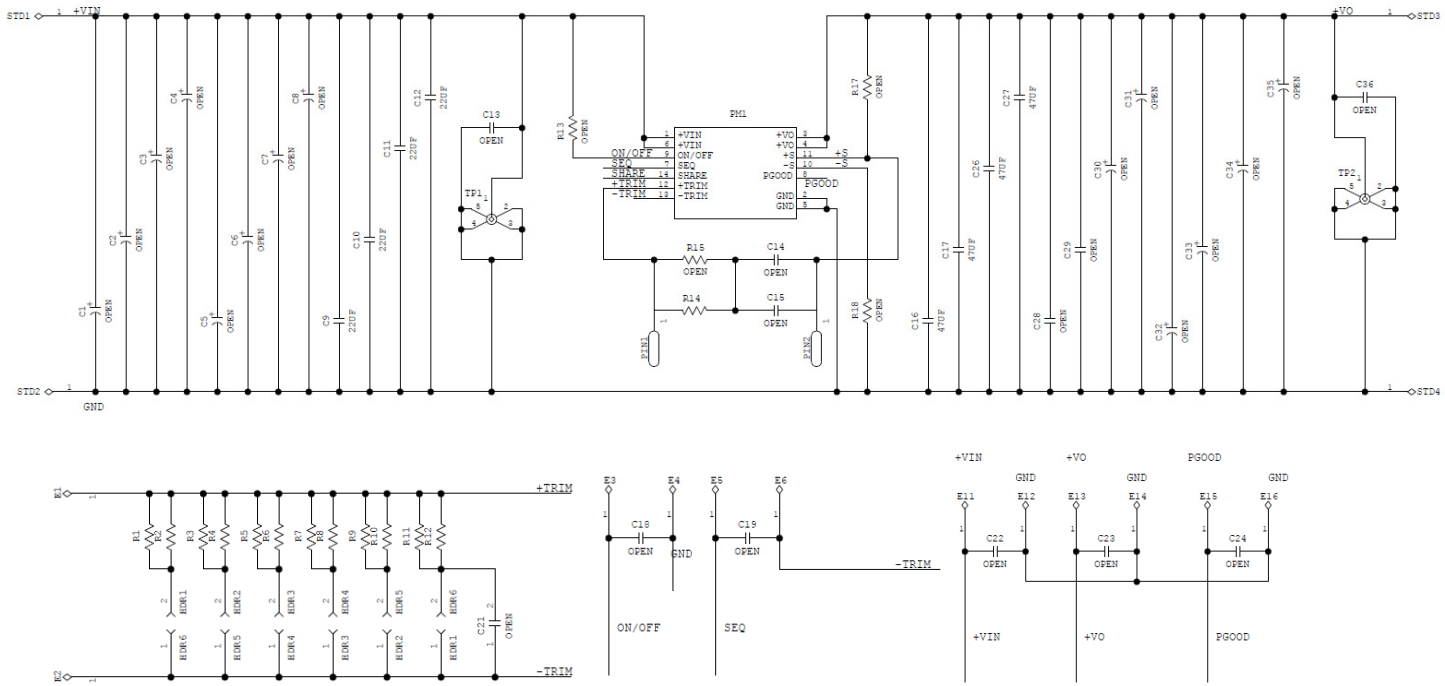

Figure 3. Schematic of the GigaTLynx Evaluation board.

2. Physical Descriptions

An annotated photograph of the PicoTLynx/MicroTLynx/ProLynx evaluation board is provided in the figure below. The notes indicate locations of various components. A minimum list of external components are the trim resistor R34/R35, input filtering (a $1\mu\text{F} + 2 \times 22\mu\text{F}, 16\text{Vmin}$) ceramic capacitors are recommended as a minimum and are already assembled on the board) and some modest amount of output filtering ($1\mu\text{F} + 10\mu\text{F}$ ceramic). Please refer to module datasheet for minimum specified capacitance.

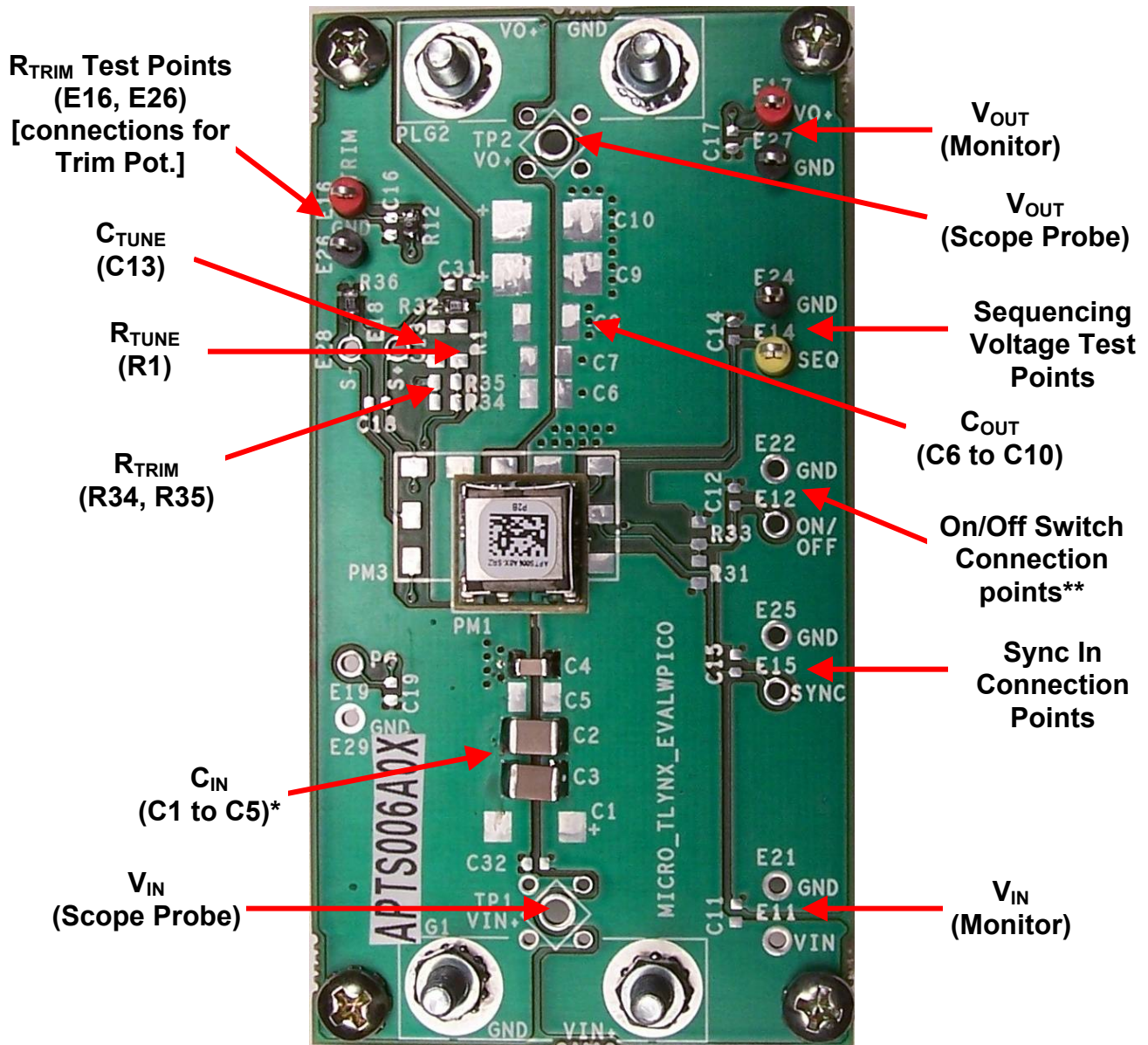

Figure 4 - PicoTLynx/MicroTLynx/ProLynx evaluation board

Caution! Before applying power, make sure that the unit under test and the externally installed capacitors (input & output) have appropriate voltage ratings.

Notes: Module can be trimmed either by soldering fixed resistor(s) @ R34/R35 or by attaching a trim potentiometer/resistor between test points E16 and E26.

* 50V cap rating for ProLynx modules

**For ProLynx module, On/Off should be shorted to ground for module to turn-on

An annotated photograph of the MicroTLynx/ProLynx/TLynx/MegaTLynx evaluation board is provided in the figure below. The notes indicate locations of various components. A minimum list of external components are the trim resistor R34/R35, input filtering (a $1\mu\text{F} + 2 \times 22\mu\text{F}$, 16V/50Vmin) ceramic capacitors are recommended as a minimum and are already assembled on the board) and some modest amount of output filtering ($1\mu\text{F}+10\mu\text{F}$ ceramic). Please refer to module datasheet for minimum specified capacitance. The ProLynx board needs at least 50V rated input caps

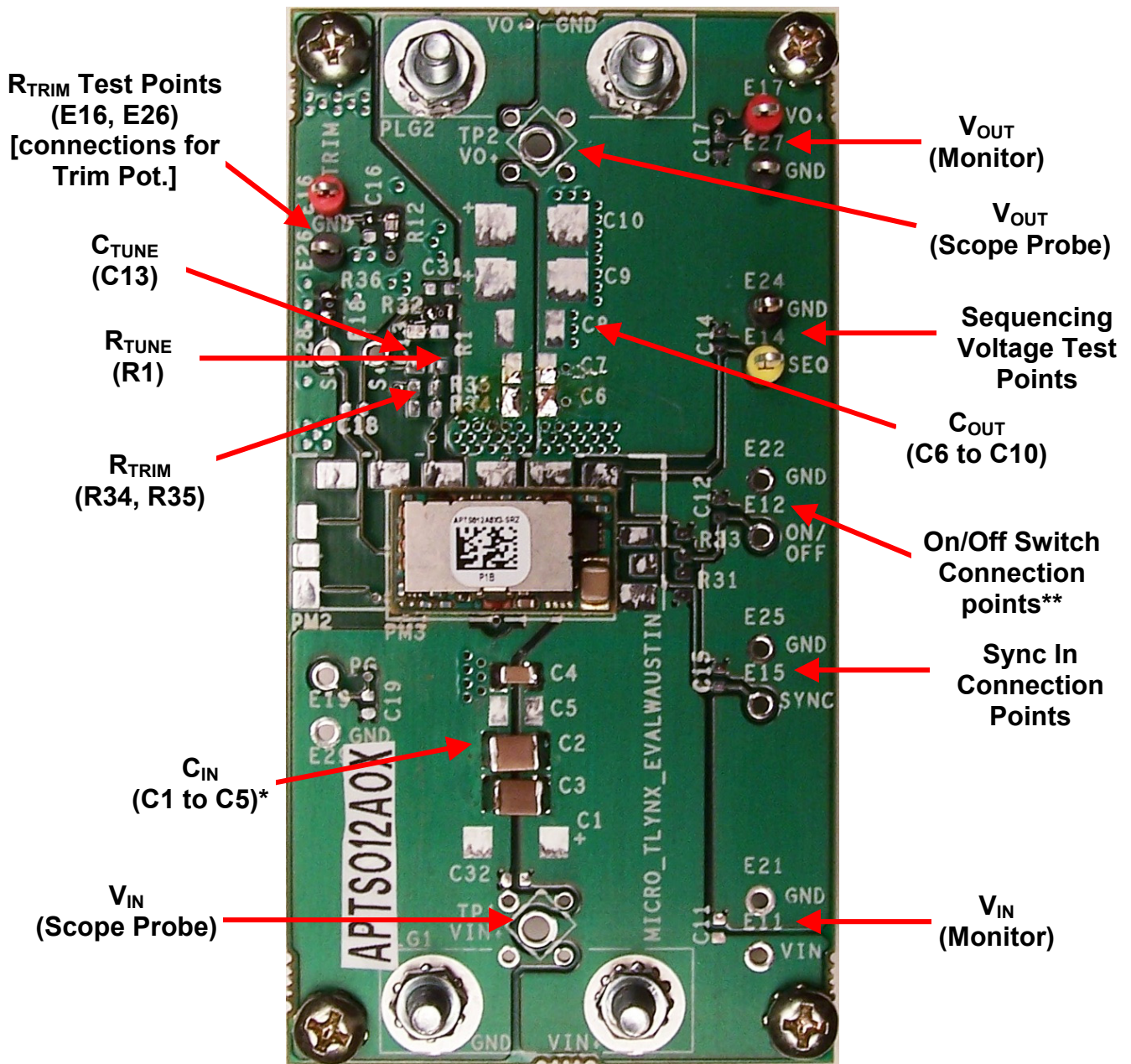

Figure 5 - MicroTLynx/ProLynx/TLynx/MegaTLynx evaluation board

Caution! Before applying power, make sure that the unit under test and the externally installed capacitors (input & output) have appropriate voltage ratings.

Notes: Module can be trimmed either by soldering fixed resistor(s) @ R34/R35 or by attaching a trim potentiometer/resistor between test points E16 and E26.

* 50V cap rating for ProLynx modules

**For ProLynx module, On/Off should be shorted to ground for module to turn-on

An annotated photograph of the Giga TLynx evaluation board is provided in the figure below. The notes indicate locations of various components. A minimum list of external components are input filtering (4 x 22 μ F, 16Vmin ceramic capacitors are recommended as a minimum and are already assembled on the board) and some modest amount of output filtering (1 μ F+2x10 μ F ceramic, 4Vmin). Please refer to module datasheet for minimum specified capacitance.

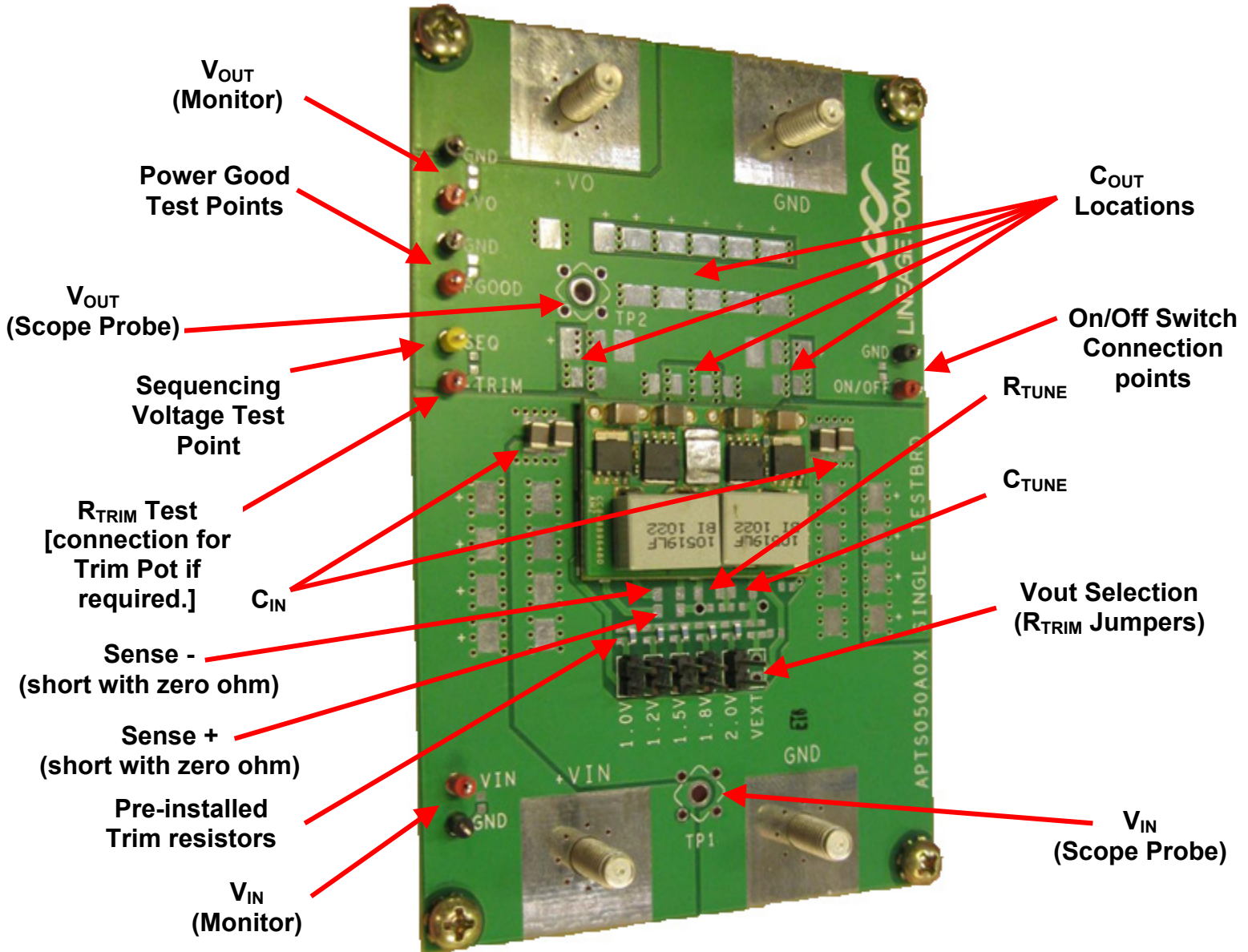

Figure 6 – Giga TLynx evaluation board

Caution! Before applying power, make sure that the unit under test and the externally installed capacitors (input & output) have appropriate voltage ratings.