

## 1A, 1.5MHz, 6V CMCOT Synchronous Step-Down Converter

### ***Purpose***

The RT5710A is a high efficiency synchronous step-down DC-DC converter. Its input voltage range is from 2.5V to 6V and provides an adjustable regulated output voltage from 0.6V to 3.4V while delivering up to 1A of output current. This document explains the function and use of the RT5710A evaluation board (EVB), and provides information to enable operation, modification of the evaluation board and circuit to suit individual requirements.

## Table of Contents

Purpose .....	1
Introduction.....	2
Key Performance Summary Table .....	2
Bench Test Setup Conditions .....	3
Schematic, Bill of Materials & Board Layout .....	5
More Information.....	12
Important Notice for Richtek Evaluation Board .....	12

## Introduction

### General Product Information

The RT5710A is a high efficiency synchronous step-down DC-DC converter. Its input voltage range is from 2.5V to 6V and provides an adjustable regulated output voltage from 0.6V to 3.4V while delivering up to 1A of output current. The internal synchronous low on-resistance power switches increase efficiency and eliminate the need for an external Schottky diode. The Current Mode Constant-On-time (CMCOT) operation with internal compensation allows the transient response to be optimized over a wide range of loads and output capacitors.

### Product Feature

- Efficiency Up to 95%
- $R_{DS(on)}$  160m $\Omega$  HS / 110m $\Omega$  LS
- $V_{IN}$  Range 2.5V to 6V
- $V_{REF}$  0.6V with  $\pm 2\%$  Accuracy
- CMCOT™ Control Loop Design for Best Transient Response, Robust Loop Stability with Low-ESR (MLCC)  $C_{OUT}$
- Fixed Soft-Start 1.2ms
- Cycle-by-Cycle Over-Current Protection
- Input Under-Voltage Lockout
- Output Under-Voltage Protection (UVP Hiccup)
- Thermal Shutdown Protection
- Power Saving at Light Load

### Key Performance Summary Table

Key Features	Evaluation Board Number : PCB104_V1
Default Input Voltage	3.3V
Max Output Current	1A
Default Output Voltage	1.2V
Default Marking & Package Type	RT5710AHGQW, WDFN-6L 2x2
Operation Frequency	1.5MHz in CCM mode

## Bench Test Setup Conditions

### Headers Description and Placement

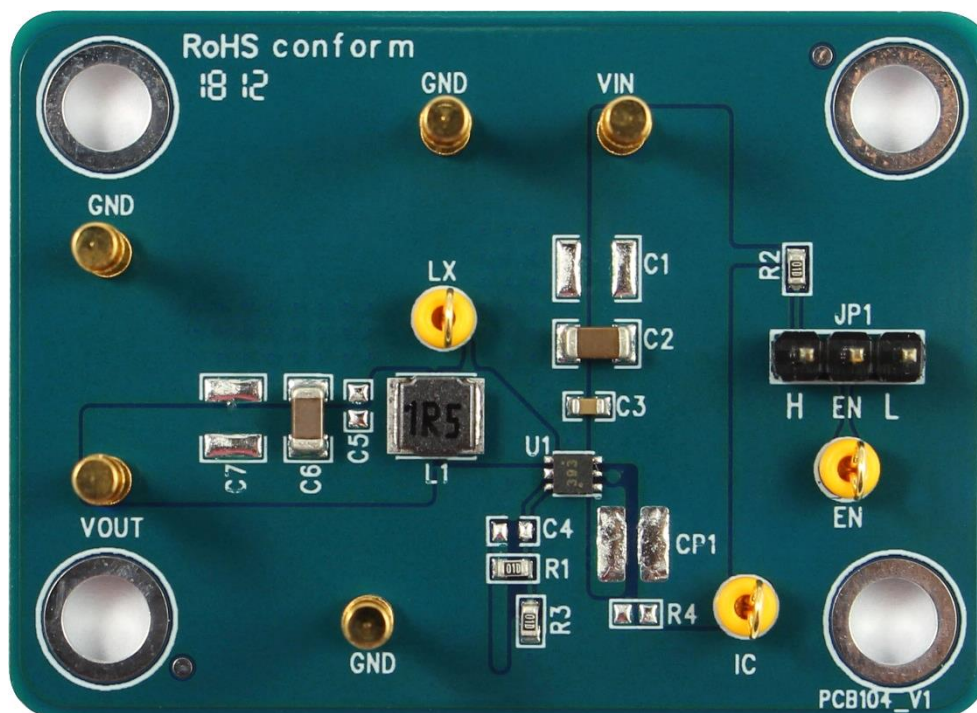

Carefully inspect all the components used in the EVB according to the following Bill of Materials table, and then make sure all the components are undamaged and correctly installed. If there is any missing or damaged component, which may occur during transportation, please contact our distributors or e-mail us at [evb\\_service@richtek.com](mailto:evb_service@richtek.com).

### Test Points

The EVB is provided with the test points and pin names listed in the table below.

Test point/ Pin name	Signal	Comment (expected waveforms or voltage levels on test points)
<b>NC, IC</b>	No Internal Connection	No internal connection.
<b>EN</b>	Enable Control Input	Enable control input.
<b>VIN</b>	Supply Voltage Input	The RT5710A operates from a 2.5V to 6V input.
<b>LX</b>	Switch Node	Switch node.
<b>GND</b>	Ground	Ground. The exposed pad must be soldered to a large PCB and connected to GND for maximum thermal dissipation.
<b>FB</b>	Feedback	Feedback.
<b>VOUT</b>	Output Voltage	Output voltage.

**Power-up & Measurement Procedure**

1. Apply a 3.3V nominal input power supply ( $2.5V < V_{IN} < 6V$ ) to the VIN and GND terminals.
2. Set the jumper at JP1 to connect terminals 2 and 3, connecting EN to VIN through resistor R2 (100k $\Omega$ ). The Enable pin can be connected to VIN directly as well to enable operation.
3. Verify the output voltage (approximately 1.2V) between VOUT and GND.
4. Connect an external load up to 1A to the VOUT and GND terminals and verify the output voltage and current.

**Output Voltage Setting**

Set the output voltage with the resistive divider (R1, R3) between VOUT and GND with the midpoint connected to FB. The output is set by the following formula :

$$V_{OUT} = V_{FB} \times \left(1 + \frac{R1}{R3}\right)$$

The placement of the resistive divider should be within 5mm of the FB pin. The resistance of R3 is suggested between 10k $\Omega$  and 150k $\Omega$  to minimize power consumption, and noise pick-up at the FB pin. The resistance of R1 can then be obtained as below :

$$R1 = \frac{R3 \times (V_{OUT} - V_{FB})}{V_{FB}}$$

For better output voltage accuracy, divider resistors (R1 and R3) should have tolerance of  $\pm 1\%$  tolerance or better.

**Schematic, Bill of Materials & Board Layout**

**EVB Schematic Diagram**

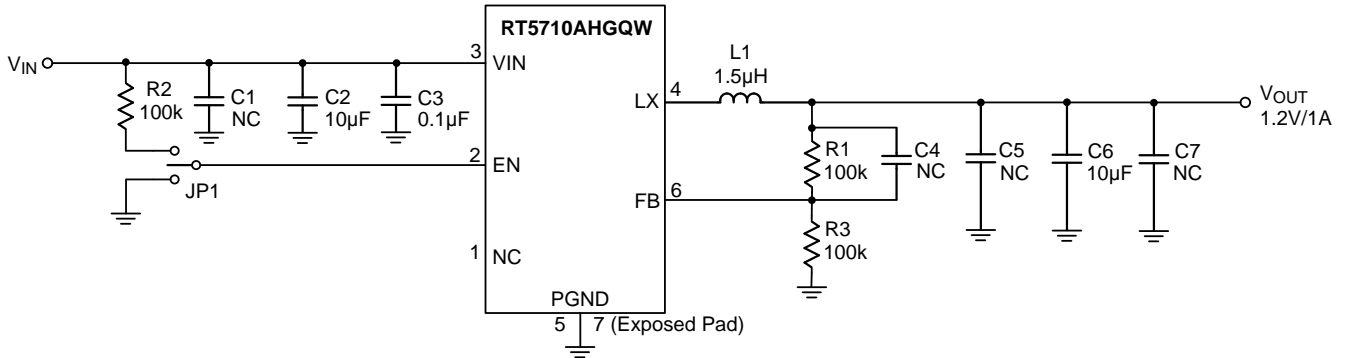

C2, C6 : 10µF/25V/1206 X7R GRM31CR71E106KA12L  
L1 : 1.5µH, 31mΩ, I<sub>SAT</sub> = 4.3A, Würth 74404042015

**Note :**

1. Do not hot-plug a live 3.3V supply to the board; if hot-plugging is required, add ~100µF electrolytic capacitor at the input.

A small feedforward capacitor (C4) can be introduced into the feedback network to speed up the transient response of high output voltage circuits. Adding C4 can also improve the light load PSM switching behavior. The feedforward capacitor is added across the upper FB divider.

To optimize transient response, C4 value is chosen so that the gain and phase boost of the feedback network increases the bandwidth of the converter, while still maintaining an acceptable phase margin. Generally, larger C4 values provide higher bandwidth, but may result in an unacceptable phase margin or instability.

**Measurement Results**

<p>Output ripple measurement, 10mA load Blue : V<sub>OUT</sub> ; Cyan : V-LX</p>	<p>Output ripple measurement, 1A load Blue : V<sub>OUT</sub> ; Cyan : V-LX</p>
<p>Ch1 Pk-Pk 24.0mV Ch2 Freq 1.368MHz Waveform Intensity: 95%</p>	<p>Ch1 Pk-Pk 5.60mV Ch2 Freq 1.519MHz</p>
<p>Output ripple : 24mVpp</p>	<p>Output ripple : 5.6mVpp, Frequency : 1.519MHz</p>

<p>Dynamic load 30mA to 800mA Blue : V<sub>OUT</sub> ; Green : Load current step</p>	<p>Dynamic load 300mA to 800mA Blue : V<sub>OUT</sub> ; Green : Load current step</p>
<p>Ch1 Max 13.0mV Ch1 Min -30.0mV Ch4 High 810mA Ch4 Low 30.0mA</p>	<p>Ch1 Max 13.0mV Ch1 Min -15.0mV Ch4 High 810mA Ch4 Low 300mA</p>
<p>Overshoot : 13mV, undershoot : 30mV</p>	<p>Overshoot : 13mV, undershoot : 15mV</p>

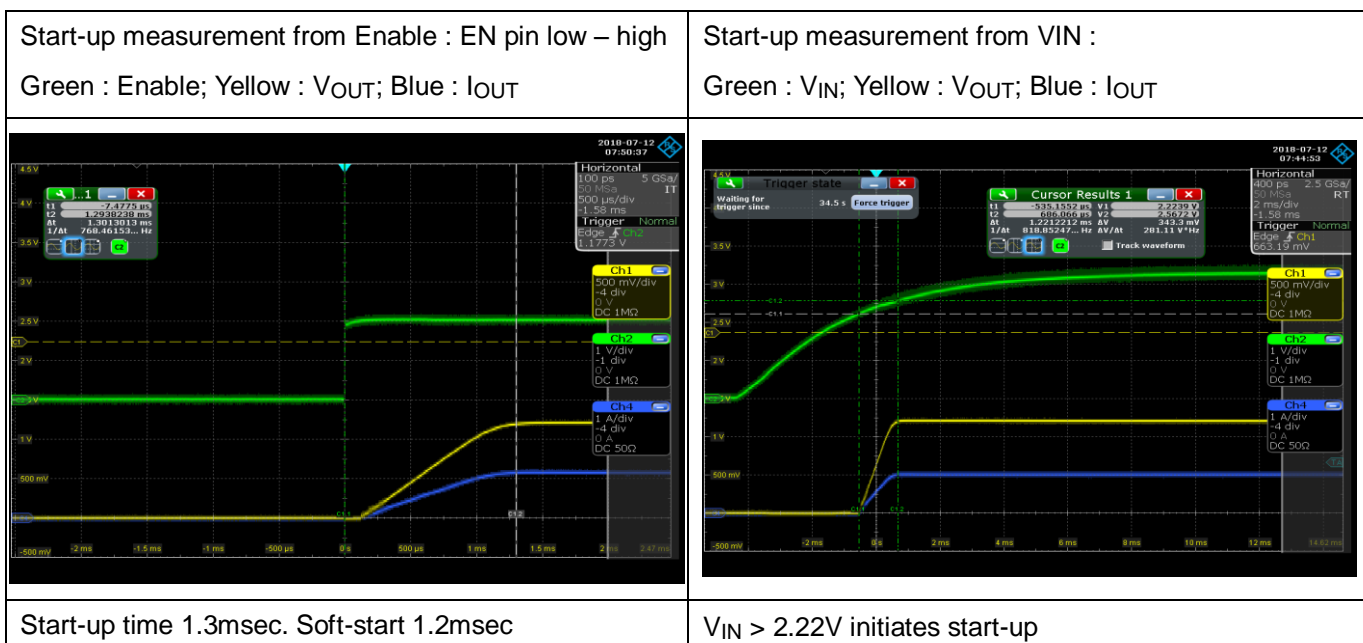
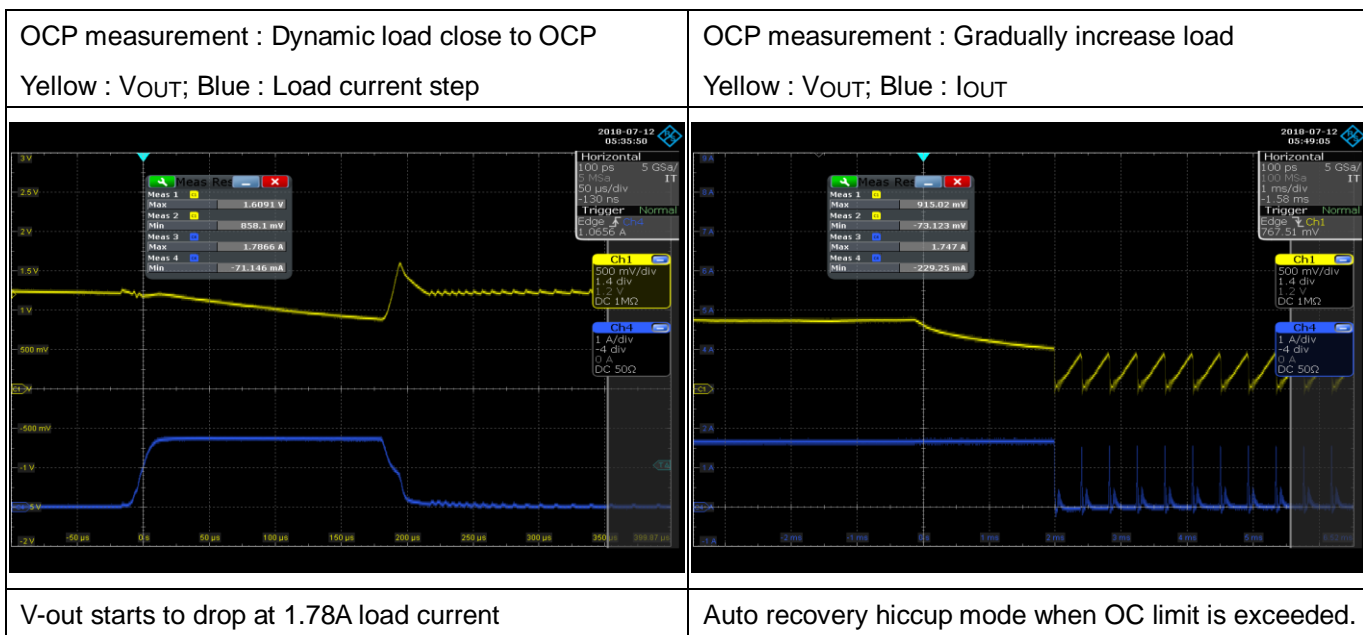

**Efficiency Measurements**

3.3V to 1.2V

$V_{IN}$ (V)	$V_{OUT}$ (V)	$I_{IN}$ (A)	$I_{OUT}$ (A)	Efficiency (%)
3.299	1.220	0.0005141	0.001	71.93
3.299	1.220	0.00433738	0.01	85.26
3.299	1.215	0.04215278	0.1	87.37
3.299	1.203	0.12214476	0.3	89.56
3.299	1.203	0.20562464	0.5	88.67
3.299	1.203	0.33956308	0.8	85.91
3.300	1.202	0.43489106	1	83.75

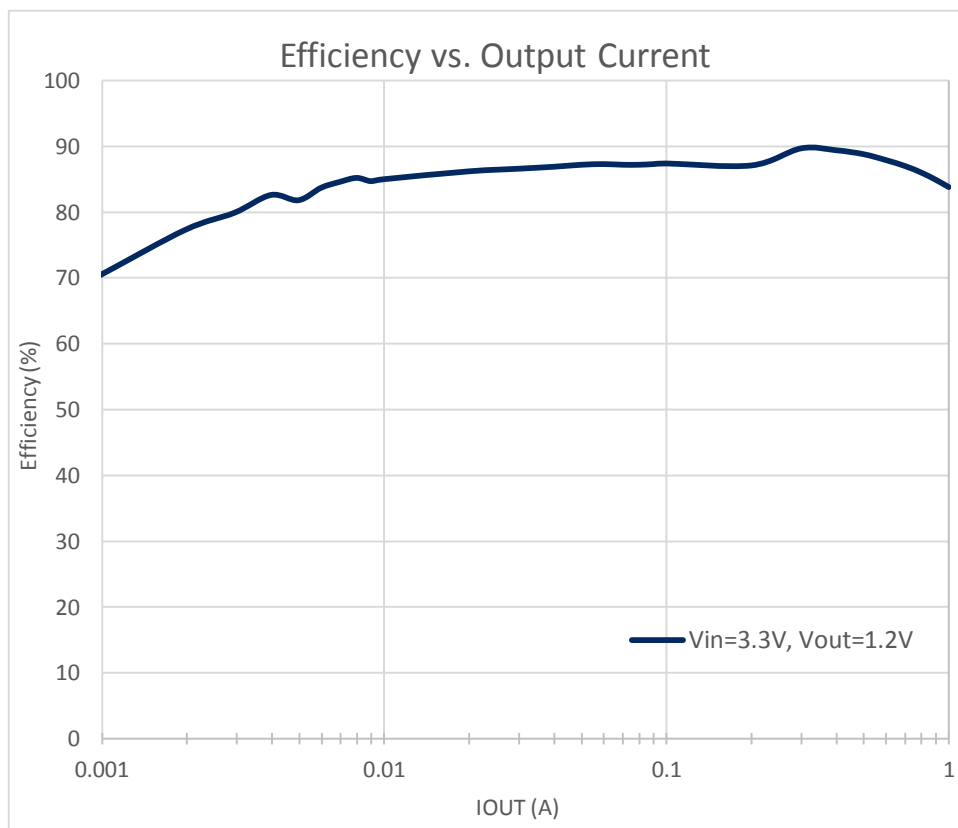



**Bill of Materials**

Reference	Qty	Part Number	Description	Package	Manufacturer
U1	1	RT5710AHGQW	DC-DC Converter	WDFN-6L 2x2	Richtek
C1, C7	2		NC	C-1206	
C2, C6	2	GRM31CR71E106KA12L	10uF/25V/X7R/1206	C-1206	MURATA
C3	1	C1608X7R1H104K080AA	100nF/50V/X7R/0603	C-0603	TDK
C4, C5	1		NC	C-0603	
L1	1	74404042015	1.5μH	4.0x4.0x1.8mm	WURTH ELEKTRONIK
R1, R2, R3	3		100k/0603	R-0603	
R4	1		NC	R-0603	

**PCB Layout**

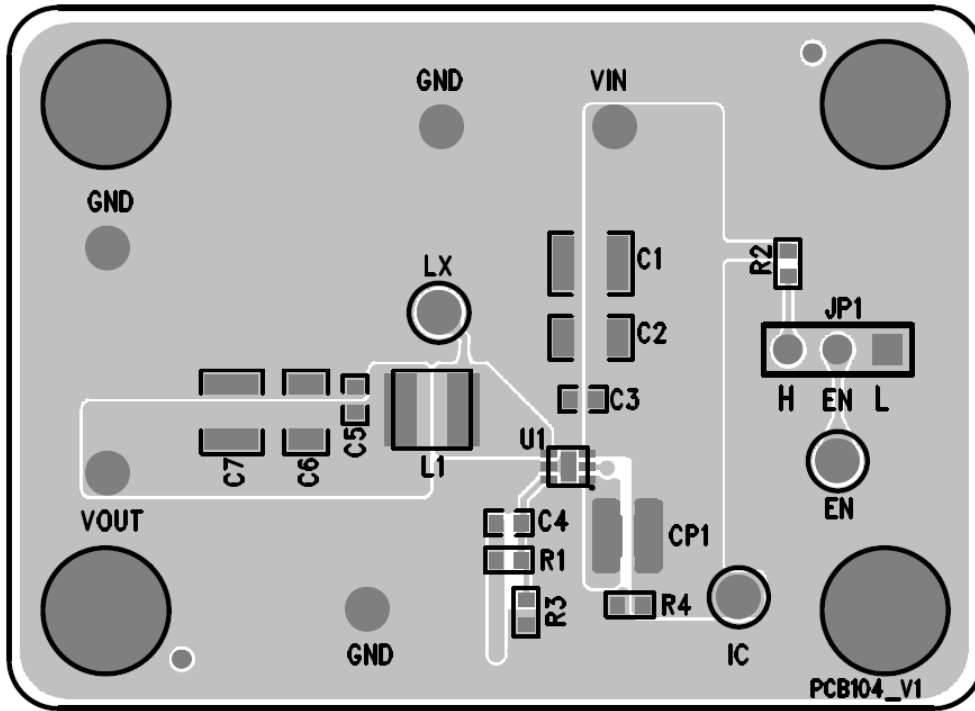

Top View (1<sup>st</sup> layer)

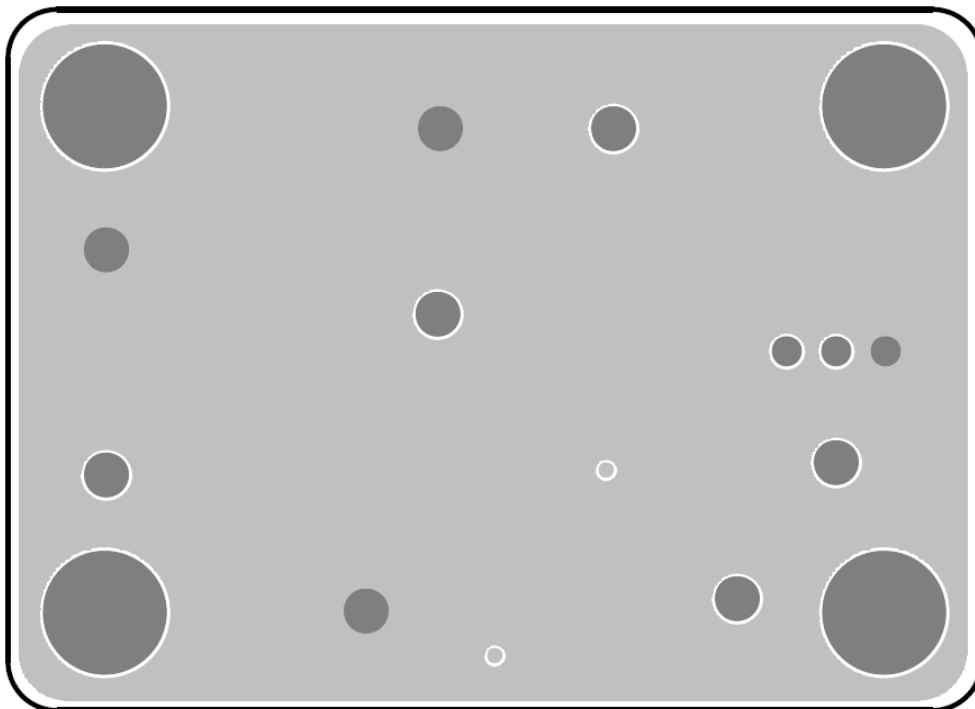

PCB Layout—Inner Side (2<sup>nd</sup> Layer)

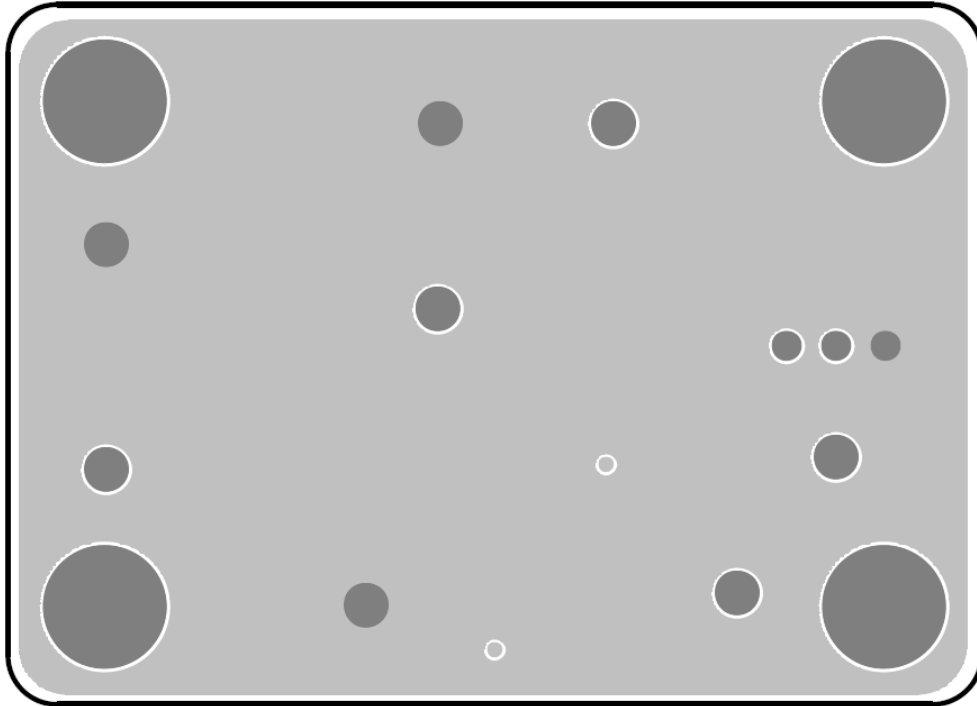

PCB Layout—Inner Side (3<sup>rd</sup> Layer)

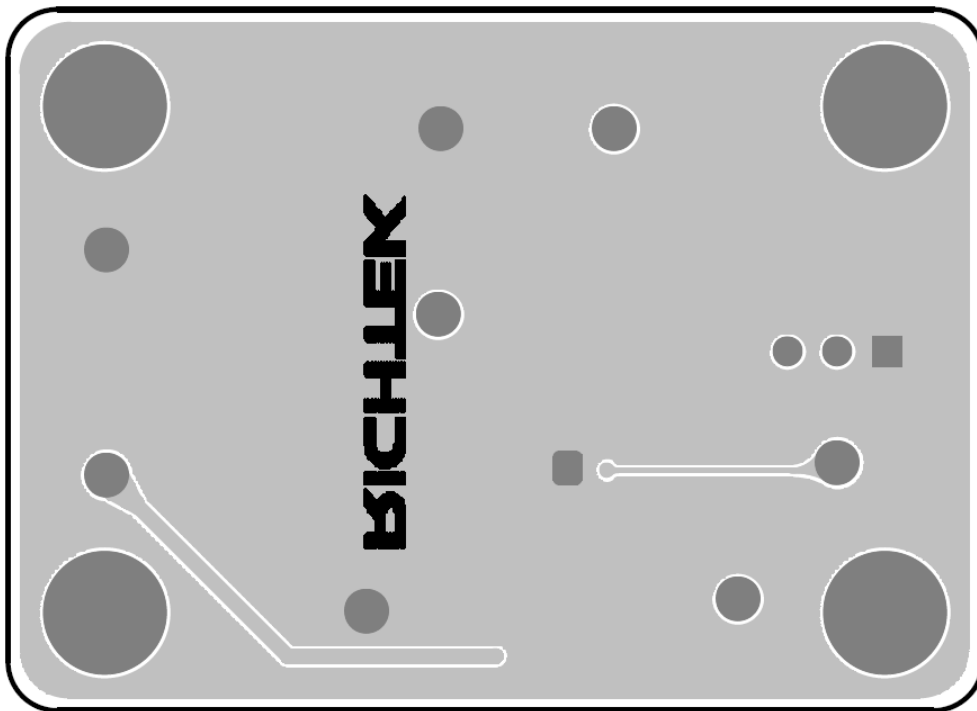

Bottom View (4<sup>th</sup> Layer)