

## **2A, 6V, 1.5MHz, 25 $\mu$ A I<sub>Q</sub>, ACOT™ Synchronous Step-Down Converter**

### ***Purpose***

The RT5784A is a current mode step-down converter with the input voltage range from 2.5V to 6V and provides 2A output current. This document explains the function and use of the RT5784A evaluation board (EVB), and provides information to enable operation, modification of the evaluation board and circuit to suit individual requirements.

## **Table of Contents**

Purpose.....	1
Introduction .....	2
Bench Test Setup Conditions.....	3
Schematic, Bill of Materials & Board Layout.....	5
More Information.....	6
Important Notice for Richtek Evaluation Board.....	8

## Introduction

### General Product Information

The RT5784A is a high-performance, Advanced Constant On-Time (ACOT™) monolithic synchronous step-down DC/DC converter that can deliver up to 2A output current from a 2.5V to 6V input supply. The proprietary ACOT control architecture features quick transient response and provides stable operation with small ceramic output capacitors and without complicated external compensation. The switching ripple voltage is easily smoothed-out by small package filtering elements due to a constant switching frequency of 1.5MHz and the maximum duty cycle of 100% allows the device to operate at low dropout use. With internal low on-resistance power switches and extremely low quiescent current, the RT5784A displays excellent efficiency and good behavior across a range of applications. Cycle-by-cycle current limit provides protection against shorted outputs, input under-voltage lock-out, output under-voltage protection, and thermal shutdown provide safe and smooth operation in all operating conditions. The RT5784A is available in the WDFN-8JL 2x1.5 (FC) package.

### Product Feature

- Dramatically Fast Transient Response
- Steady 1.5MHz  $\pm 200$ kHz Switching Frequency
- Very Low Input Quiescent and Shutdown Currents
- Advanced COT Control Loop Design
- Optimized for Ceramic Output Capacitors
- 2.5V to 6V Input Voltage Range
- Accurate Voltage Reference 0.6V  $\pm 2\%$
- Integrated 100m $\Omega$ /60m $\Omega$  MOSFETs
- Internal Start-Up into Pre-biased Outputs
- Power Good Indicator
- Enable Control
- Over-Current and Over-Temperature Protections
- Under-Voltage Protection with Hiccup Mode
- RoHS Compliant and Halogen Free

### Key Performance Summary Table

Key Features	Evaluation Board Number: PCB078_V1
Default Input Voltage	5V
Max Output Current	2A
Default Output Voltage	1.0V
Default Marking & Package Type	RT5784AGQWF, WDFN-8JL 2x1.5 (FC)
Operation Frequency	Steady 1.5MHz at all loads

## Bench Test Setup Conditions

### Headers Description and Placement

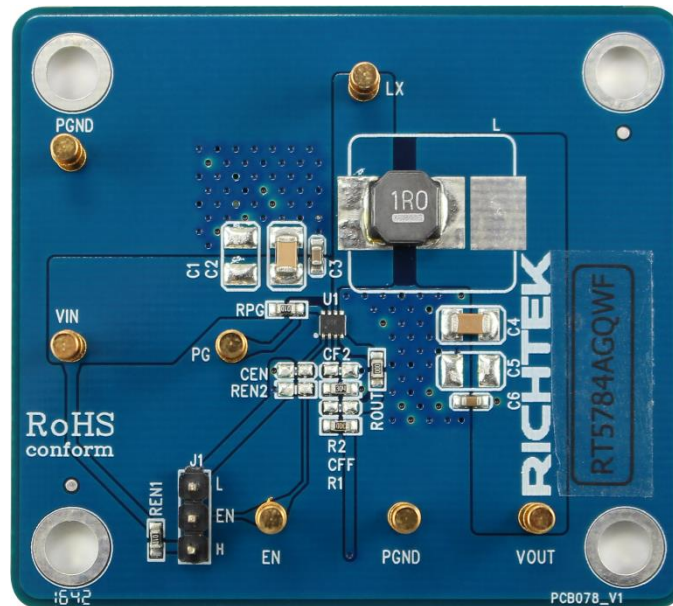

Carefully inspect all the components used in the EVB according to the following Bill of Materials table, and then make sure all the components are undamaged and correctly installed. If there is any missing or damaged component, which may occur during transportation, please contact our distributors or e-mail us at [evb\\_service@richtek.com](mailto:evb_service@richtek.com).

### Test Points

The EVB is provided with the test points and pin names listed in the table below.

Test point/ Pin name	Signal	Comment (expected waveforms or voltage levels on test points)
<b>VIN</b>	Input voltage	Supply Input. Supplies the power to the internal control circuit as well as the power switches of the device. Drive VIN with a 2.5V to 6V power source and bypass VIN to PGND with a suitably large capacitor to eliminate noise on the input to the IC.
<b>EN</b>	Enable test point	Enable Control Input. Connecting this pin to logic high can enable the device and connecting this pin to GND can disable the device.
<b>PGND</b>	Ground	Power Ground. This pin must be soldered to a large PCB and connected to analog ground for maximum power dissipation.
<b>FB</b>	Feedback voltage input	Feedback Voltage Input. This pin is used to set the desired output voltage via an external resistive divider. The feedback reference voltage is 0.6V typically.
<b>PGOOD</b>	Power Good test point	Power Good Indicator Output. This pin is an open-drain logic output that is pulled to ground when the output voltage is lower or higher than its specified threshold under the conditions of UVP, OTP, dropout, EN shutdown, or during slow start.
<b>VOUT</b>	Output Voltage	Output Voltage Sense Input. This pin is used to monitor and adjust output voltage for superior load transient regulation.
<b>LX</b>	Switch node test point	Switch Node. LX is the switching node that supplies power to the output and connect the output LC filter from LX to the output load.
<b>AGND</b>	Ground	Analog Ground. Provides the ground return path for control circuitry and internal reference.

### ***Power-up & Measurement Procedure***

1. Connect input power ( $2.5V < V_{IN} < 6V$ ) and input ground to VIN and GND test pins respectively.
2. Connect positive end and negative terminals of load to VOUT and GND test pins respectively.
3. There is a 3-pin header “EN” for enable control. To use a jumper at “H” option to tie EN test pin to input power VIN for enabling the device. Inversely, to use a jumper at “L” option to tie EN test pin and ground GND for disabling the device.
4. Verify the output voltage (approximately 1.0V) between VOUT and GND.
5. Connect an external load up to 2A to the VOUT and GND terminals and verify the output voltage and current.

### ***Output Voltage Setting***

Set the output voltage with the resistive divider (R1, R2) between VOUT and GND with the midpoint connected to FB. The output is set by the following formula:

$$V_{OUT} = V_{FB} \times (1 + R1 / R2)$$

**Schematic, Bill of Materials & Board Layout**

**EVB Schematic Diagram**

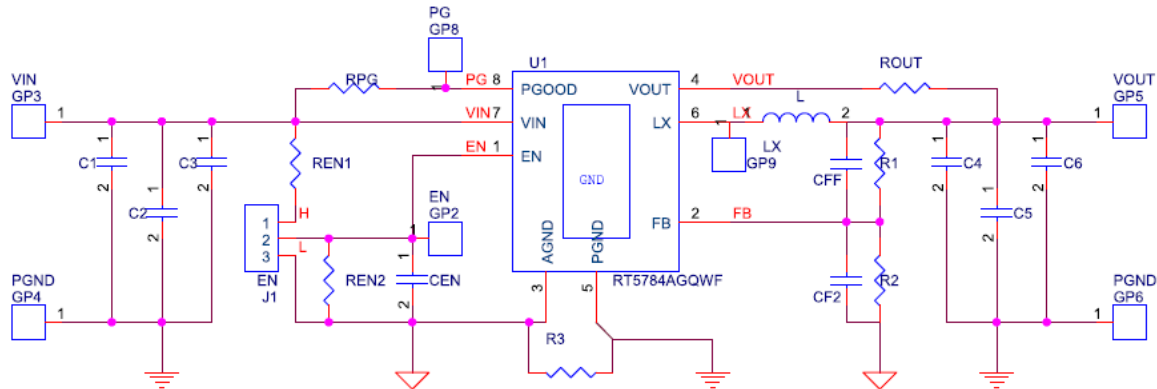

**Bill of Materials**

Reference	Qty	Part number	Description	Package	Manufacturer
U1	1	RT5784AGQWF	RT5784AGQWF	WDFN-8JL 2x1.5 (FC)	RICHTEK
REN2, CF2, CEN, CFF, C1, C5	6	NC	NC		
C2, C4	2	10 $\mu$ F/1210,16V	10 $\mu$ F/25V/X5R/1206		TDK
C3, C6	2	0.1 $\mu$ F/0603	0.1 $\mu$ F/ $\pm$ 10%/50V/X7R/0603		TDK
J1	1	EN	單排排針		
L	1	1 $\mu$ H	1.0uH/4.2A/6mm*6mm	6x6x4.5mm	TAIYO YUDEN
REN1, RPG	2	100k/0603	100k/0603		WALSIN
ROUT	1	0R	0R		WALSIN
R1	1	200k/0603	200k/0603		WALSIN
R2	1	300k/0603	300k/0603		WALSIN
R3	1	0 ohm	0R		WALSIN

**PCB Layout**

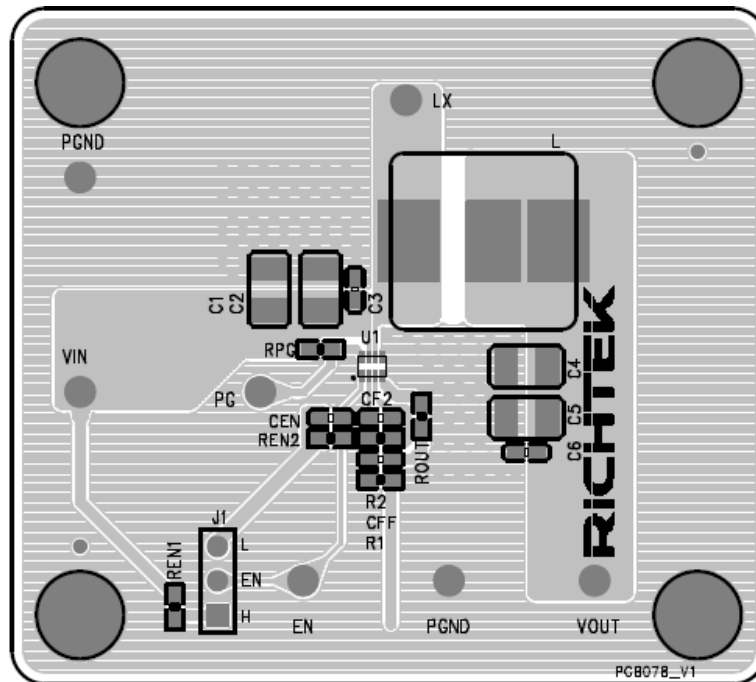

Top View (1<sup>st</sup> layer)

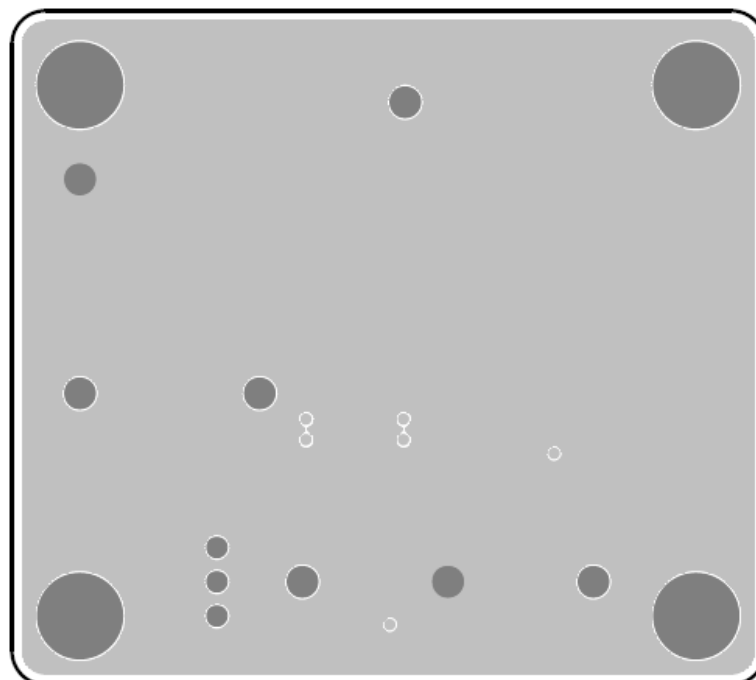

PCB Layout—Inner Side (2<sup>nd</sup> Layer)

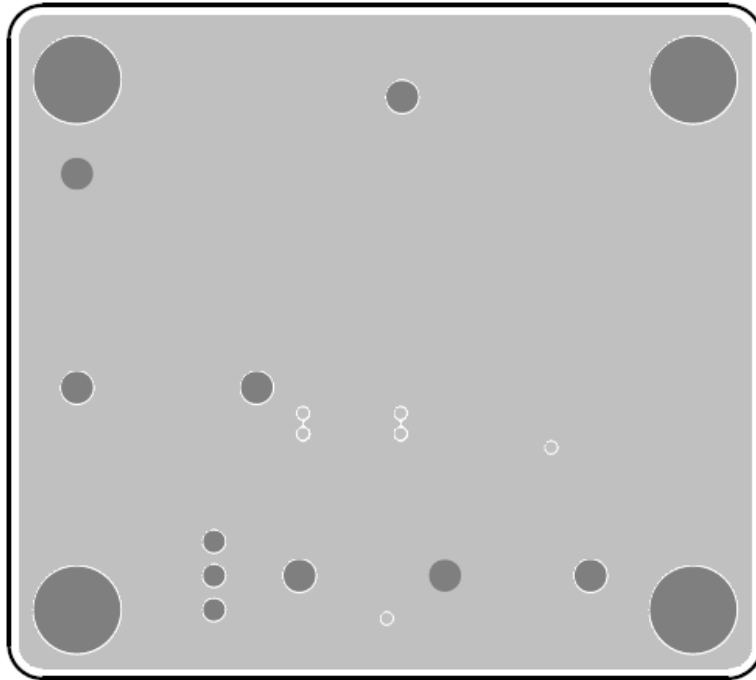

PCB Layout—Inner Side (3<sup>rd</sup> Layer)

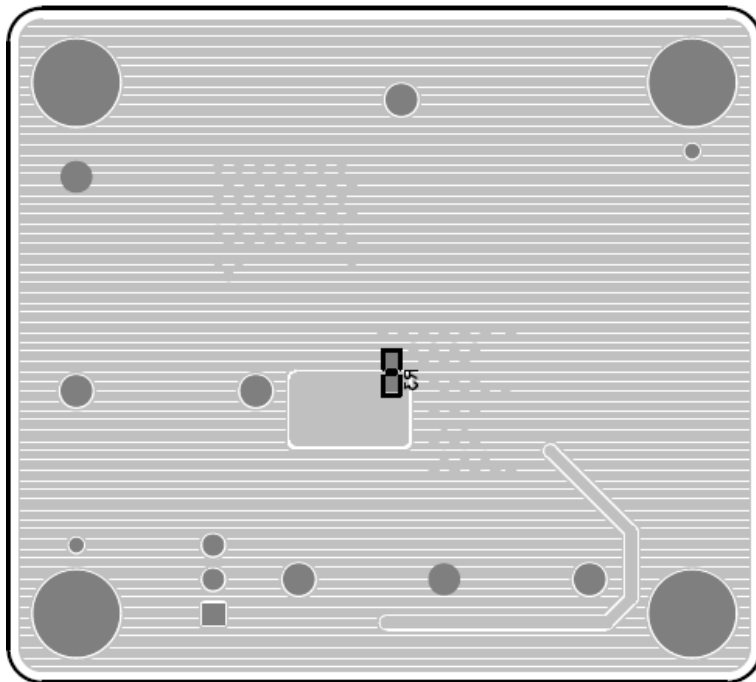

Bottom View (4<sup>th</sup> Layer)