

PRODUCT SPECIFICATION FOR APPROVAL

Product Description: : ENCODER
Product Part Number : (Panasonic Part Number: EVERQHPK016B)
Country of Origin : VIETNAM (Indicated on the packing label in English)
Applications : Model :

- * In case of use other than the application described above, contact Panasonic representatives.
- * If you approve this specification, please fill in and sign the below and return 1 copy to us.

Approval No. :	
Approval Date :	
Executed by :	
_____ (Signature)	
Title :	
Dept. :	

Electromechanical Components Business Division
1006 Kadoma, Kadoma City, Osaka, Japan
Phone: (06) 6908-7304 (Direct)

Prepared by : Input Devices Development Team
Contact Person : Engineering Group

Signature 
Name (Print) : A. Matsumoto
Title : Staff Engineer
Phone : +81-868-26-3791

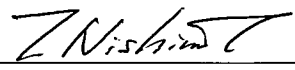
Authorized by : 
Signature : T. Nishimoto
Name (Print) : T. Nishimoto
Title : Team Leader of Engineering

Classification	SPECIFICATIONS		Issue No. 1898
Part Name 11mm GS Encoder	Part No. EVERQHPK016B		2/10

1. Notification items.

1.1 Information of Chemical Substance and Environmental Hazardous Substances.

- This product has not been manufactured with ozone depleting chemical controlled under the Montreal Protocol.
- This product complies with the RoHS Directive (Restriction of the use of certain Hazardous Substance in electrical and electronic equipment (DIRECTIVE 2011/65/EU).
- All the materials used in this part are registered material under the Law Concerning the Examination and Regulation of Manufacture etc. or Chemical Substances.
- This product does not yet confirm to Halogen Free regulation generally required.

1.2 Limitation of Application

- This product has been designed and manufactured for general electronic devices, such as home electronics, office equipment, information devices and communication devices.
In an event that this product is used for more sophisticated applications requiring higher safety and reliability and its failure or malfunction of this product may impose damage to human life or property, agreement on product specifications for approval suitable for such applications are required.
Such applications shall include the following:
 - aircraft equipment, aerospace equipment, disaster prevention / crime prevention equipment, medical equipment, transportation equipment (vehicles, trains, ships, etc.), information processing equipment that are highly publicized, and other equivalent equipment
- Regardless of its applications, in an event that this product is used for the equipment requiring high safety levels, place protective circuits or redundant circuits and perform safety tests to improve your products' safety.

1.3 Export control

When going through export procedures, please comply with laws and regulations related to export control such as Foreign Exchange and Foreign Trade Law.

1.4 Handling of approval specification

- Writings in this specification from are subject to change through precautions.
- This specification from specify this item only. Please perform your approval test in the actual equipment conditions beforehand.

1.5 Manufacturing sites

Production country : Vietnam

Production factory : Panasonic Industrial Devices Vietnam Co.,Ltd

Address : Plot J1, J2 Thang Long Industrial Park, Dong Anh District, Hanoi, VIETNAM

2. Outline

- 2.1 This specification applied to rotary encoder used in electronic equipment.
- 2.2 This specification is a constituent document of contract for business concluded between your company and Panasonic Corporation.
- 2.3 Item not particularly specified in this specification shall be in conformance with JIS Standards.

Classification

SPECIFICATIONS

Issue No.

1898

Part Name

11mm GS Encoder

Part No.

EVERQHPK016B

3/10

3. Shape and dimension, Circuit diagram, Marking

3.1 Shape and dimension (General dimension tolerance : $\pm 0.5\text{mm}$) <Unit : mm>

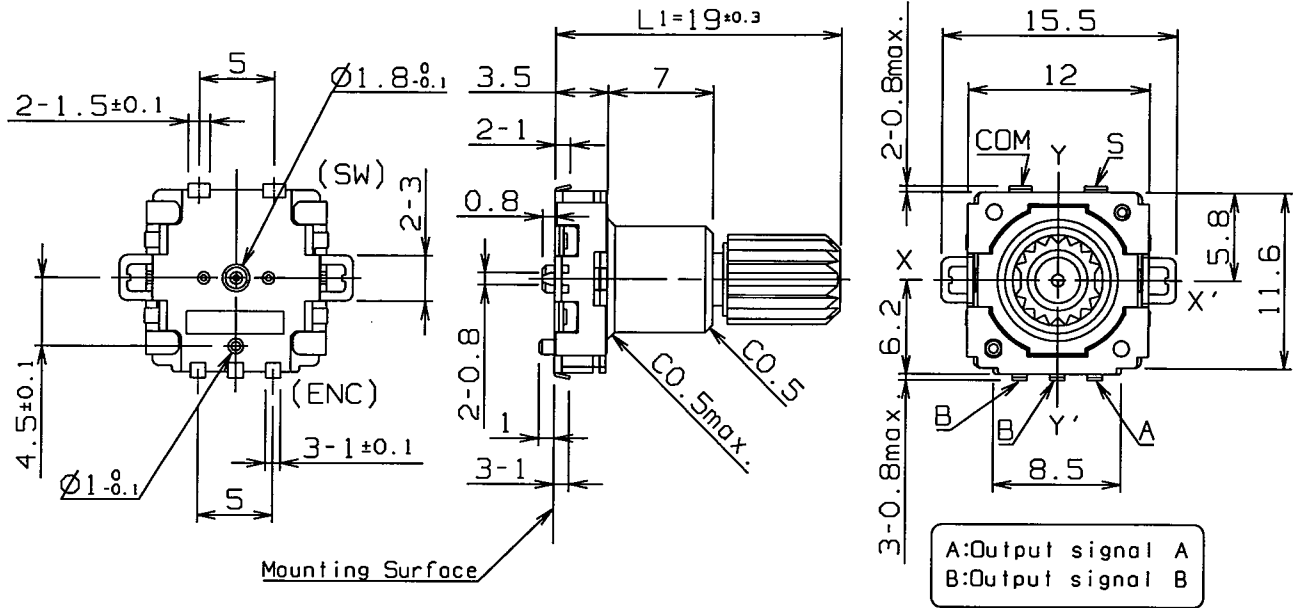

Shaft shape and dimension

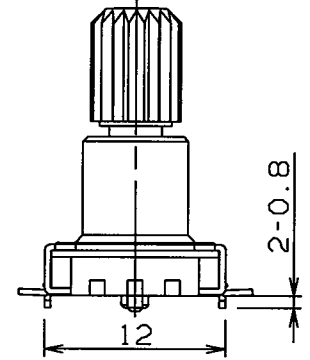
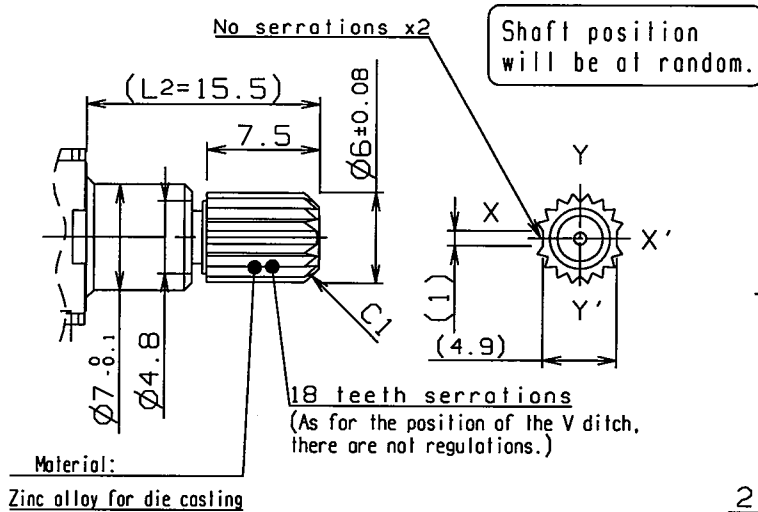

Recommended land pattern plan.

(Tolerance : ± 0.1)

(View from mounting side)

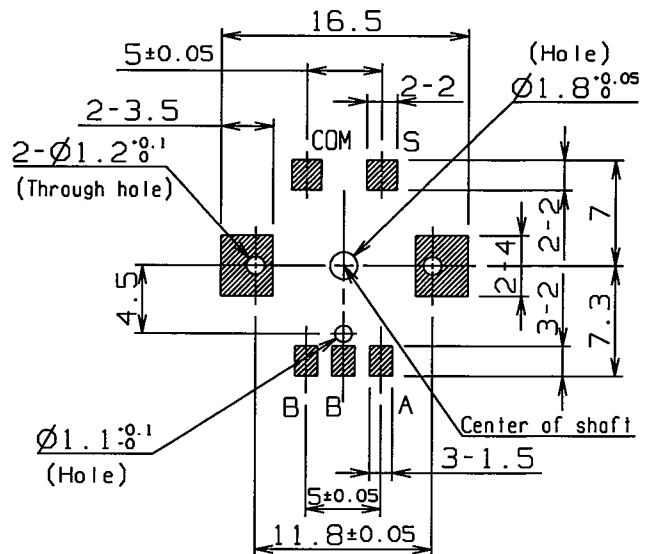

Marking

1. Date code
2. Out put signal
3. VN (Distinction of production country)

Classification	SPECIFICATIONS		Issue No. 1898
Part Name 11mm GS Encoder	Part No. EVERQHPK016B		4/10

Encoder terminal layout and switch circuit diagram.

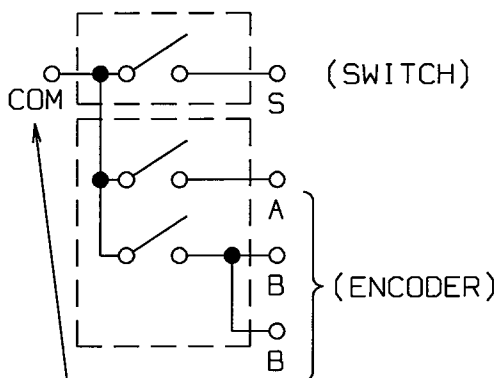

(Notice)
Common terminal is shared
between encoder and switch

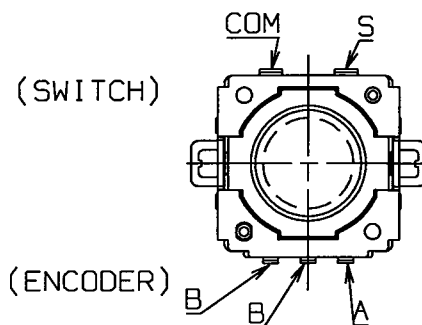

ENCODER: A:Output signal A
B:Output signal B

SWITCH: D:Output signal
for switch
E:Output signal
for switch

4. General

- 4.1 Rated voltage :Encoder part D.C 10V
Switch part D.C 16V
- 4.2 Rated current :Encoder part D.C 1mA
Switch part D.C 20mA
- 4.3 Operating temperature range : -40°C to +85°C
- 4.4 Storage temperature range : -40°C to +85°C
- 4.5 Standard atmospheric conditions

Unless otherwise specified. The standard range of atmospheric conditions for making measurements and tests is as follows.

Ambient temperature : 15°C to 35°C
Relative humidity : 25% to 75%
Air pressure : 86kPa to 106kPa

Classification	SPECIFICATIONS		Issue No. 1898
Part Name 11mm GS Encoder	Part No. EVERQHPK016B		5/10

5. Performance

5.1 Mechanical performance (Encoder part)

Item		Conditions		Specifications
5.1.1	Rotation angle			360° (Endless)
5.1.2	Detent points			32 detent point
5.1.3	Each detent angle			11.25°±3°
5.1.4	Rotation torque (Detent torque) (Average torque)	Operating temperature	5°C~85°C	Before reflow soldering 12.0mNm ± 6.0mNm After reflow soldering 10.0mNm ± 6.0mNm
			-20°C~5°C	40 mN·m max.
			-40°C~-20°C	50 mN·m max.
5.1.5	Shaft pull-push strength	Pull and push static load of 100N shall be applied to the shaft in the axial direction for 10 second. (Mount the product to P.W.B)		Without damage or excessive play in shaft. No excessive abnormality in rotational feeling. And electrical characteristics shall be satisfied.
5.1.6	Shaft side-load strength	A momentary load of 0.5N shall be applied at the point 5mm from the tip of the shaft in a direction perpendicular to the axis of shaft for 10 second. (Mount the product to P.W.B)		Without excessive play or bending in shaft. No excessive abnormality in rotational feeling. And electrical characteristics shall be satisfied.
5.1.7	Shaft wobble	A momentary load of 50 mNm shall be applied at the point 2mm from the tip of the shaft in a direction perpendicular to the axis of shaft. (Mount the product to P.W.B)		0.65xL/30 mm(P-P)max. L=Distance between mounting surface and measuring point on the shaft.
5.1.8	Shaft play in rotational wobble	Measure with jig for rotational angle.		2° max.

5.2 Mechanical performance (Switch part)

Item		Conditions		Specifications
5.2.1	Switch type			Push type S.P.S.T.
5.2.2	Switch operation force	Measure the max. load until switch turned on when pressing the center of shaft to the operation direction of push SW.		6.0 N ± 2.5 N
5.2.3	Push stroke	Measure the distance until switch turned on when pressing the center of shaft to the operation direction of push SW. < Switch feeling curve (Fig.-8)>		0.4mm ± 0.2 mm (At push force 8.5N)
				0.3mm ± 0.15 mm (Travel to ON)

Classification	SPECIFICATIONS		Issue No. 1898
Part Name 11mm GS Encoder	Part No. EVERQHPK016B		6/10

5.3 Electrical performance (Encoder part)

Item	Conditions	Specifications
5.3.1	Output signal (Output of phase difference Fig-1)	A,B 2 signals.
5.3.2	Output resolution	Number of pulses in 360° rotation. 16Pulse / 360°
5.3.3	Contact resistance	Measurement shall be stable condition which a output signal is ON condition. 1 Ω max.
5.3.4	Bouncing	Measurement circuit diagram.(Fig-2) At rotational speed 60 min ⁻¹ <Phase t1,t3 (Fig-3)> (Passing time between 3.5V and 1.5V) t1,t3: 5 ms max.
5.3.5	Sliding noise phase	Take sliding noise as time in the code-on area between bouncing(t1,t3) and voltage change exceed 1.5V.(Fig-3) Rotate shaft at speed 60 \pm 3 min ⁻¹ and measure. t2: 3 ms max.
5.3.6	Phase-difference	Measurement shall be made under the condition which the shaft is rotated at 60 min ⁻¹ . T1, T2, T3, T4 (Fig-1) 4 ms min.
5.3.7	Insulation resistance	Measurement shall be made under the condition which a voltage of 250V D.C. is applied between individual terminals and a shaft. 50M Ω min.
5.3.8	Withstand voltage	A voltage of 300V A.C. shall be applied for 1min. between individual terminals and a shaft. Without arcing or breakdown.

5.4 Electrical performance (Switch part)

Item	Conditions	Specifications
5.4.1	Bouncing	Measurement circuit diagram.(Fig-4) At operation speed 3~4 times/s <Phase t4,t5 (Fig-5)> (Passing time between 3.5V and 1.5V) t4,t5: 10ms max.
5.4.2	Contact resistance	Measurement the contact resistance between COM and SW when push SW is ON. Applying force: 7.0N 100m Ω max.
5.4.3	Insulation resistance	Measurement shall be made under the condition which a voltage of 250V D.C. is applied between individual terminals and a shaft. 50M Ω min.
5.4.4	Withstand voltage	A voltage of 300V A.C. shall be applied for 1min. between individual terminals and a shaft. Without arcing or breakdown.

Phase difference.
(Fig-1)

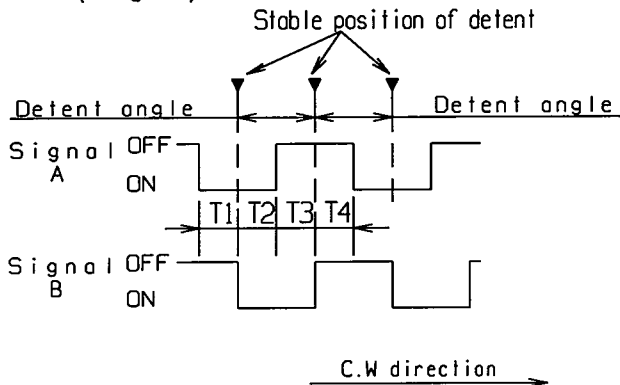

Measurement circuit diagram.
(Fig-2)

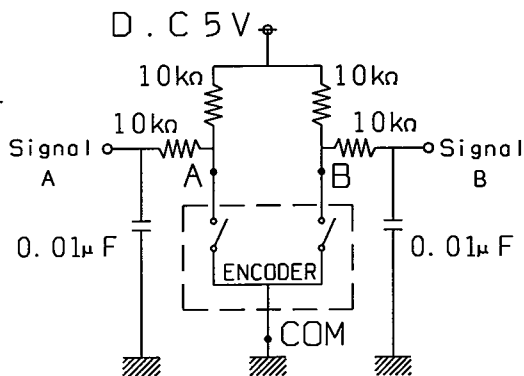

At each detent position, output between COM and A is stable ON or OFF.
(Output between COM and B is not specified.)

Bouncing phase (Fig-3)

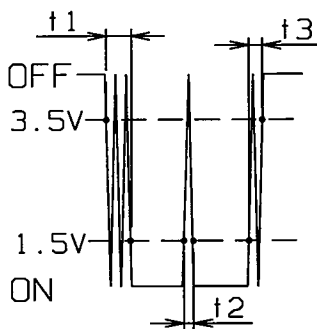

Measurement circuit diagram (Fig-4)

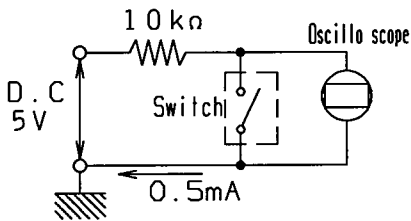

Bouncing phase (Fig-5)

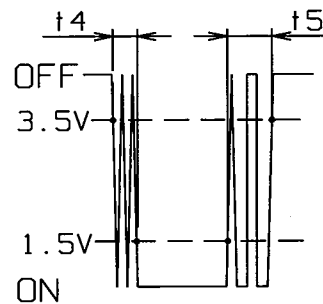

Classification		SPECIFICATIONS	Issue No. 1898
Part Name	11mm GS Encoder	Part No. EVERQHPK016B	8/10

5.5 Durability performance

	Item	Conditions	Specifications
5.5.1	Rotation life (Encoder)	The shaft of encoder shall be rotated to 30,000 cycles at a speed of 600 to 1000 cycles/h in room temp(15°C to 35°C) without electrical load after which measurements shall be made. (1 cycle is 360° rotation of CW and 360° rotation of CCW)	Rotation torque: Initial torque ±70% Phase-difference: 2.5 ms min. Contact resistance: 100 Ω max. Clause 5.3.4, 5.3.5, 5.3.7, 5.3.8 be conformed
5.5.2	Push operating life (Switch)	Apply 8.5N push strength to shaft to the switch operating direction. The shaft of encoder shall be pushed to 30,000 times at a speed of 2500 times/h in room temp(15°C to 35°C) without electrical load after which measurements shall be made.	Operation force: Initial operation force ±40% Contact resistance: 200 Ω max. Clause 5.4.1, 5.4.3, 5.4.4 be conformed
5.5.3	Heat temperature	The encoder shall be stored at a temperature of 85±3°C for 240±10h in a thermostatic chamber. And then the encoder shall be subjected to standard atmospheric conditions for 1.5h after which measurements shall be made. (Without electrical load)	Contact resistance: 100 Ω max. SW Contact resistance: 200 Ω max. Clause 5.1.4, 5.3.4 to 5.3.8 5.4.1 to 5.4.4 be conformed
5.5.4	Humidity	The encoder shall be stored at a temperature of 60±3°C with relative humidity of 90% to 95% for 240±10h in a thermostatic chamber. And then the encoder shall be subjected to standard atmospheric conditions for 1.5h after which measurements shall be made. (Without electrical load)	
5.5.5	Low temperature	The encoder shall be stored at a temperature of -40±3°C for 240±10h in a thermostatic chamber. And then the encoder shall be subjected to standard atmospheric conditions for 1.5h after which measurements shall be made. (Without electrical load)	

Classification

SPECIFICATIONS

Issue No.

1898

Part Name

11mm GS Encoder

Part No.

EVERQHPK016B

9/10

6. Packing:

- (1) Package style : Card bord box.(250pcs./pack)
- (2) Package size : W:160 X L:260 X H:130
- (3) Tray style : Plastic tray.(50pcs./tray)
- (4) Tray size : W:150 X L:248 X H:25

Carton Box Size

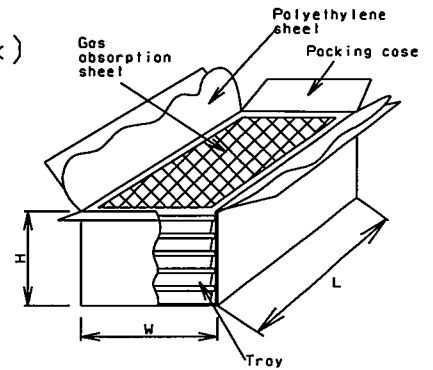

Packing Tray Configuration

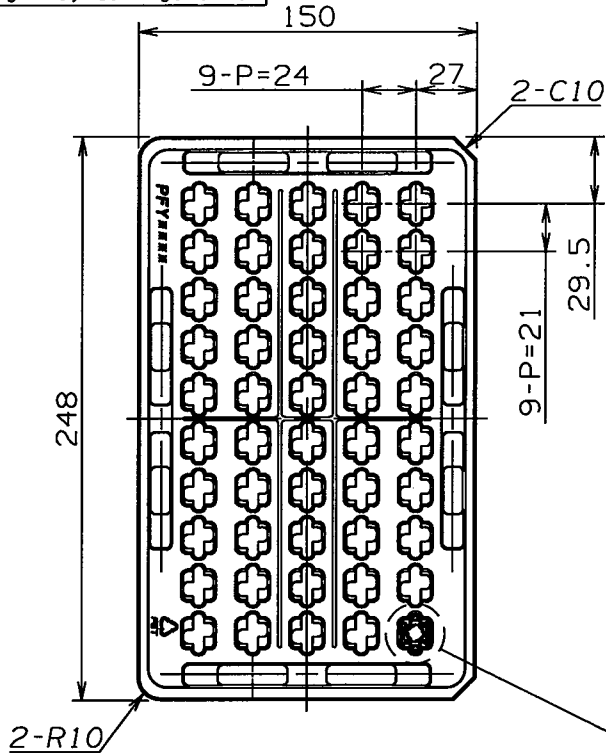

Take out direction.

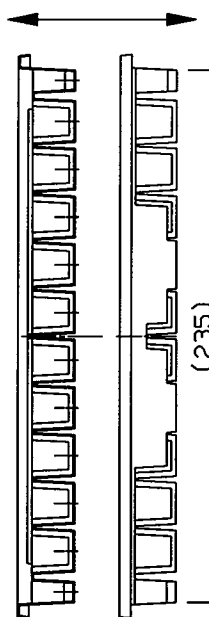

Details of Cavity
Product Direction

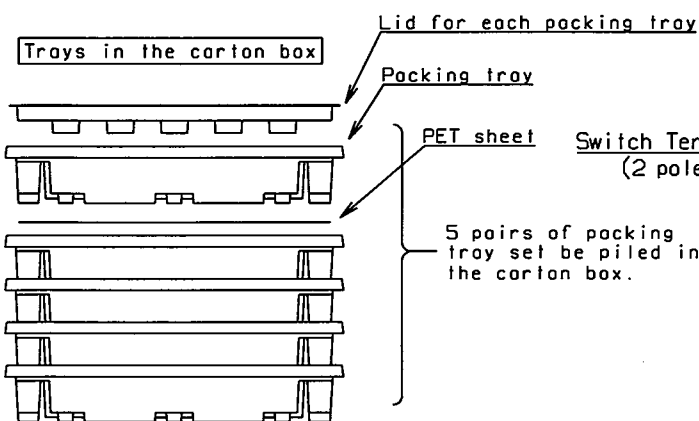
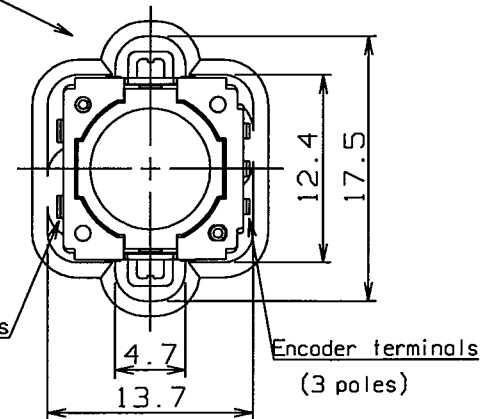
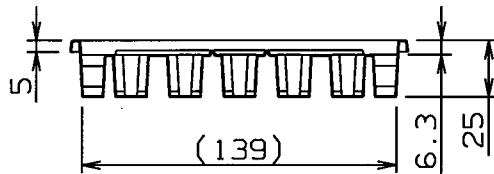

Classification	SPECIFICATIONS		Issue No. 1898
Part Name 11mm GS Encoder	Part No. EVERQHPK016B		10/10

7. Soldering conditions :

Perform the soldering under the conditions shown bellow.

Soldering conditions (1)

<Reflow soldering>

- Solder clean thickness :
t=0.15 mm - 0.2 mm
- Soldering condition(1)
<Reflow soldering>
Fig-7 2times max.
(Temperature profile of
reflow soldering)
- Prohibitive items :
You should not use preflux.

Temperature profile of reflow soldering.(Fig-7)

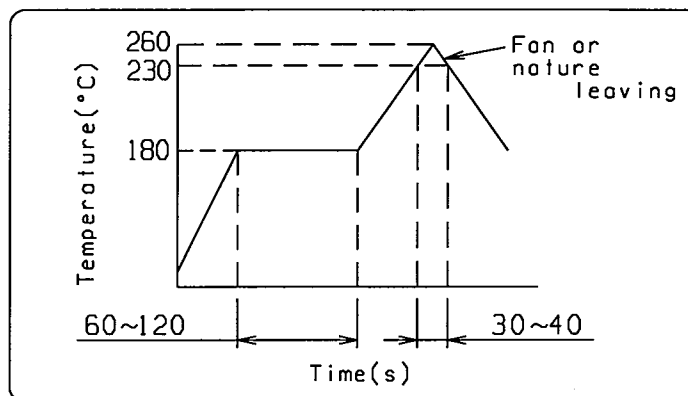

Soldering conditions (2)

<Soldering iron>

- Soldering iron : 20W or lower.
- Temperature of the iron tip : 350°C or lower.
- The duration to apply the soldering iron : 3 seconds or lower. (1 time)

PWB design - When you design mounting hole of PWB, please refer to its dimension defined in this specification.

Particularly, care should be taken in the case of wiring such as jumper wire near the product body where flux is delating.

If flux is spattered to the product body, it may cause electrical contact or sliding trouble.

8. Application Notes

8.1 Prohibited items on fire and smoking

Absolutely avoid use of a product beyond its rated range because doing so may cause a fire. If misuse or abnormal use may result under conditions in which the product is used out of its rated range, take proper measures such as current interruption using a protective circuit.

The grade of nonflammability for resin used in product is "94HB," which is based on UL94 Standards (flammability test for plastic materials).

Prohibit use in a location where a spreading fire may be generated or prepare against a spreading fire.

8.2 For use in equipment for which safety is requested

Although care is taken to ensure product quality, inferior Characteristics, short circuits, and open circuits are some problems that might be generated. To design a equipment which places maximum emphasis on safety, review the affect of any single fault of a product in advance and perform virtually fail-safe design to ensure maximum safety by:

- Preparing a protective circuit or a protective device to improve system safety, and set
- Preparing a redundant circuit to improve system safety so that the single fault of a product does not cause a dangerous situation.

8.3 Reliability

- Storage condition

Do not store the product under high temperatures and/or high humidity, or in a location where corrosive gas may be generated.

Store the product at room temperature and room humidity in a packed condition.

Use them within a maximum of 6 months.

Check the date of manufacture on the package box and apply the "first-in-first-out" rule.

If unpacked product must be stored as inventory, Store them in polyethylene bag to keep out air.

- The encoder's pulse count method should be designed with taking operating speed, sampling time, and the design of the microcomputer software, etc. into consideration.