

To: OurPCB Tech. Ltd.

Issue No. : RV-V-EVE-0087

Date of Issue : 13<sup>th</sup>. Apr .2020

Classification :  New  Change

Product Description: : 11mm GS ENCODER  
Product Part Number : Panasonic Part Number EVEUPCAH508B  
Country of Origin : VIETNAM (Indicated on the packing label in English)  
Applications :

## Provisional Product Specification

Panasonic Industrial Devices Vietnam  
Co.,Ltd.

Plot J1-J2, Thang Long Industrial Park, Kim  
Chung commune, Dong Anh District, Hanoi,  
Vietnam

Prepared by : Technical Section

Contact Person

Signature

Name (Print)

Title

Phone

Authorized by

Signature

Name (Print)

Title

: +84-243-955-0082, Ext: 3249

: Dang Thi Phuc



: Technical section Manager

All the materials used in this part are registered material under the Law  
Concerning the Examination and Regulation of Manufacture etc. or Chemical Substances.

**Panasonic**

Classification		PROVISIONAL SPECIFICATIONS		Issue No.
Part Name		Part No.		RV-V-EVE-0087
11mm GS Encoder		EVEUPCAH508B		1 / 9

REVISION'S CAREER SHEET

ISSUE	PAGE	REVISIONS	DATE	DESIGN	CHECK	APPROVAL
/	/	New issue	10.Apr.2020	PHUC		

Classification		PROVISIONAL SPECIFICATIONS	Issue No. RV-V-EVE-0087
Part Name	11mm GS Encoder	Part No. EVEUPCAH508B	2 / 9

1. Notification items.

1.1 Information of Chemical Substance and Environmental Hazardous Substances.

- This product has not been manufactured with ozone depleting chemical controlled under the Montreal Protocol.
- This product complies with the RoHS Directive (Restriction of the use of certain Hazardous Substance in electrical and electronic equipment (DIRECTIVE 2011/65/EU as amended by EU2015/863)).
- The material used in product contain only the substances listed in the List of existing Chemical Substances specified in 'Act on the Evaluation of Chemical Substances and regulation of Their Manufacture, etc'.

1.2 Limitation of Application

- This product has been designed and manufactured for general electronic devices, such as home electronics, office equipment, information devices and communication devices. In an event that this product is used for more sophisticated applications requiring higher safety and reliability and its failure or malfunction of this product may impose damage to human life or property, agreement on product specifications for approval suitable for such applications are required.
- Such applications shall include the following:
- . Aircraft equipment, aerospace equipment, disaster prevention / crime prevention equipment, medical equipment, transportation equipment (vehicles, trains, ships, etc.), information processing equipment that are highly publicized, and other equivalent equipment
  - . Regardless of its applications, in an event that this product is used for the equipment requiring high safety levels, place protective circuits or redundant circuits and perform safety tests to improve your products' safety.

1.3 Export control

When going through export procedures, please comply with laws and regulations related to export control such as Foreign Exchange and Foreign Trade Law.

1.4 Handling of provisional specification

Since the contents of this reference specification are subject to change without prior notifications. Please request us a formal specification again for your investigation before using.

1.5 Manufacturing sites

Production country : Viet Nam  
 Production factory : Panasonic Industrial Devices Vietnam Co.,Ltd  
 Address factory : Plot J1, J2 Thang Long Industrial Park, Dong Anh District, Hanoi, VietNam

2. Outline

- 2.1 This specification applied to rotary encoder used in electronic equipment.
- 2.2 This specification is a constituent document of contract for business concluded between your company and Panasonic Corporation.
- 2.3 Item not particularly specified in this specification shall be in conformance with JIS Standards.

2. Application Notes :

- 1. Avoid storing the products in a place at high temperature and high humidity and in corrosive gases.
- 2. The encoder's pulse count method should be designed with taking operating speed, sampling time, and the design of the microcomputer software, etc. into consideration.
- 3. Prohibited items on fire and smoking  
 Absolutely avoid use of a product beyond its rated range because doing so may cause a fire  
 If misuse or abnormal use may result in conditions in which the encoder is used out of its rated range, take proper measures such as current interruption using a protective circuit.  
 Please do not use the product in any location or circumstances where spreading fire may occur, or necessary measure against spreading fire if use in such locations or circumstances
- 4. For use in equipment for which safety requested  
 Although care is taken to encoder quality, inferior characteristics, short circuits, open circuits are some problems that might be generated. To design a set which places maximum emphasis on safety, review the affect of any single fault of an encoder in advance and perform virtually fail-safe design to ensure maximum safety by:
  - Preparing a protective circuit or a protective device to improve system safety, and
  - Preparing a redundant circuit to improve system safety so that the signal fault of a product encoder does not cause a dangerous situation.

Classification	PROVISIONAL SPECIFICATIONS		Issue No.
Part Name	11mm GS Encoder	Part No.	RV-V-EVE-0087
		EVEUPCAH508B	3 / 9

3. Shape and dimension, Circuit diagram, Marking

3.1 Shape and dimension (General dimension tolerance :  $\pm 0.5\text{mm}$ ) <Unit : mm>

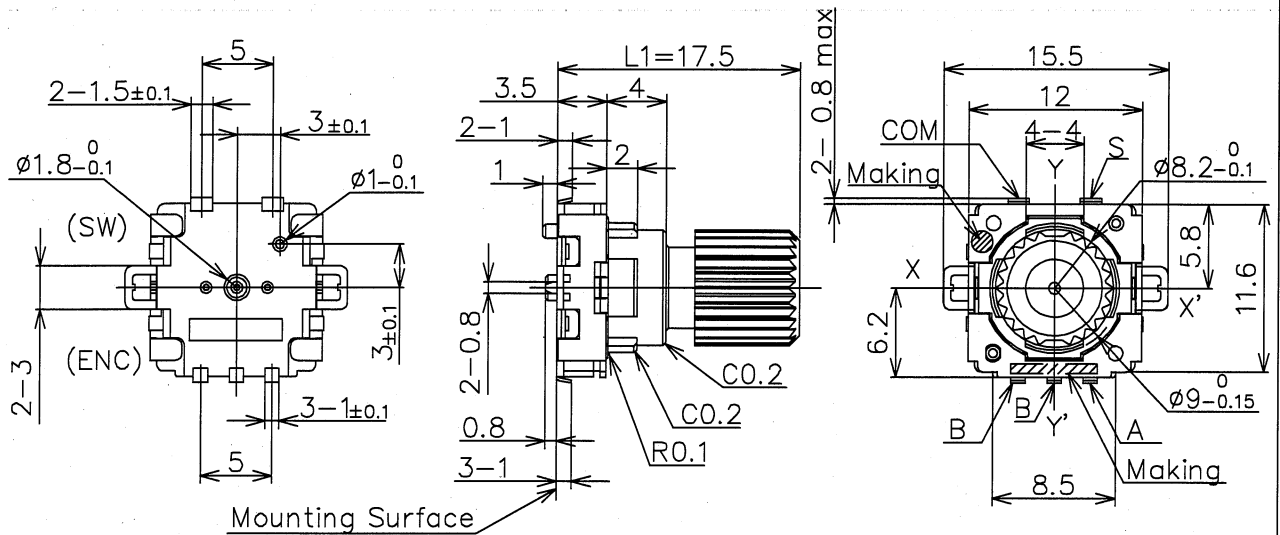

A : Output signal A  
B : Output signal B

Shaft shape and dimension

Shaft position will be at random.

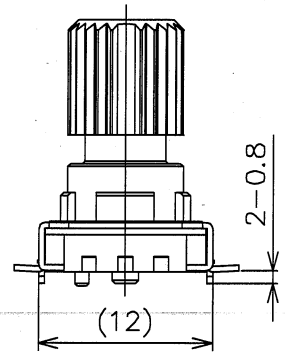
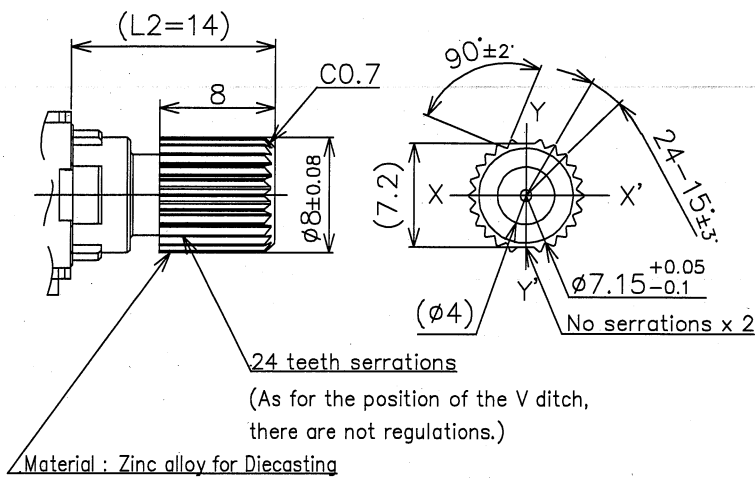

Recommended land pattern plan.

(Tolerance :  $\pm 0.1$ )  
(View from mounting side)

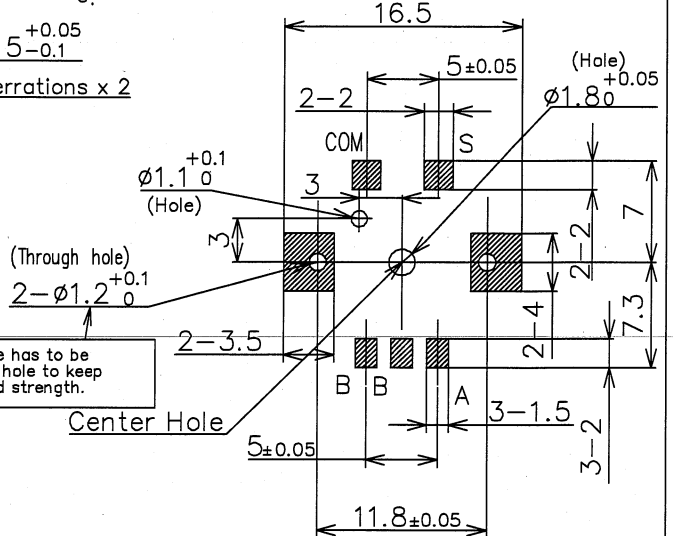

Marking

1. Date code
2. Out put signal
3. VN (Distinction of production country)

Classification	PROVISIONAL SPECIFICATIONS		Issue No.
Part Name	11mm GS Encoder	Part No.	RV-V-EVE-0087
		EVEUPCAH508B	4/ 9

#### 4. General

4.1 Standard atmospheric conditions : Unless otherwise specified. The standard range of atmospheric conditions for making measurements and tests is as follows.

Ambient temperature : 15°C ~ 35°C

Relative humidity : 25% ~ 75%

Air pressure : 86kPa ~ 106kPa

4.2 Operating temperature range : -40°C ~ +85°C

4.3 Storage temperature range : -40°C ~ +85°C

4.4 Rated voltage : Encoder D.C 10V

Switch D.C 16V

4.5 Rated current : Encoder D.C 1mA

Switch D.C 20mA

#### 5. Performance

##### 5.1 Mechanical performance(Encoder part)

Item		Conditions		Specifications
5.1.1	Rotation angle			360° (Endless)
5.1.2	Detent points			16 detent point
5.1.3	Each detent angle			22.5°±3°
5.1.4	Rotation torque (Detent torque)  (Average torque)	Operating temperature	5°C ~ 85°C	Before soldering 14.0mNm ± 8.0mNm After soldering 12.0mNm ± 7.0mNm
			-20°C ~ 5°C	40 mN·m max.
			-40°C ~ -20°C	50 mN·m max.
5.1.5	Shaft pull-push strength	Pull and push static load of 100N shall be applied to the shaft in the axial direction for 10 second.		Without damage or excessive play in shaft. No excessive abnormality in rotational feeling. And electrical characteristics shall be satisfied.
5.1.6	Shaft side-load strength	A momentary load of 0.5 Nm shall be applied at the point 5mm from the tip of the shaft in a direction perpendicular to the axis of shaft for 10 second.		Without excessive play or bending in shaft. No excessive abnormality in rotational feeling. And electrical characteristics shall be satisfied.
5.1.7	Shaft wobble	A momentary load of 50 mNm shall be applied at the point 2mm from the tip of the shaft in a direction perpendicular to the axis of shaft.		0.35xL/30 mm(P-P)max. L=Distance between mounting surface and measuring point on the shaft.
5.1.8	Shaft play in rotational wobble	Measure with jig for rotational angle.		2° max.

Classification	PROVISIONAL SPECIFICATIONS		Issue No. RV-V-EVE-0087
Part Name 11mm GS Encoder	Part No. EVEUPCAH508B	5 / 9	

### 5.2 Mechanical performance(Switch part)

Item	Conditions	Specifications
5.2.1	Switch type	Push type S.P.S.T.
5.2.2	Switch operation force	Measure the max.load until switch turned on when pressing the center of shaft to the operation direction of push SW. 6.0 N $\pm$ 2.5 N
5.2.3	Push stroke	Measure the distance until switch turned on when pressing the center of shaft to the operation direction of push SW. 0.4 mm <sup>+0.5</sup> <sub>-0.2</sub> mm (At push force 8.5N)
		0.3 mm <sup>+0.25</sup> <sub>-0.15</sub> mm (Travel to ON)

### 5.3 Electrical performance (Encoder part)

Item	Conditions	Specifications
5.3.1	Output signal	(Output of phase difference Fig-1) A,B 2 signals.
5.3.2	Output resolution	Number of pulses in 360° rotation. 8 Pulse / 360°
5.3.3	Contact resistance	Measurement shall be stable condition which a output signal is ON condition. 1 $\Omega$ max.
5.3.4	Bouncing	Measurement circuit diagram.(Fig-2) At rotational speed 60 min <sup>-1</sup> <Phase $\pm$ 1, $\pm$ 3 (Fig-3)> (Passing time between 3.5V and 1.5V) $\pm$ 1, $\pm$ 3: 5 ms max.
5.3.5	Sliding noise phase	Take sliding noise as time in the code-on area between bouncing( $\pm$ 1, $\pm$ 3) and voltage change exceed 1.5V.(Fig-3) Rotate shaft at speed 60 $\pm$ 3 min <sup>-1</sup> and measure. $\pm$ 2: 3 ms max.
5.3.6	Phase-difference	Measurement shall be made under the condition which the shaft is rotated at 60 min <sup>-1</sup> T1, T2, T3, T4 (Fig-1) 4 ms min.
5.3.7	Insulation resistance	Measurement shall be made under the condition which a voltage of 250V D.C. is applied between individual terminals and a shaft. 50M $\Omega$ min.
5.3.8	Withstand voltage	A voltage of 300V A.C. shall be applied for 1min. between individual terminals and a shaft. Without arcing or breakdown.

### 5.4 Electrical performance (Switch part)

Item	Conditions	Specifications
5.4.1	Bouncing	Measurement circuit diagram.(Fig-4) At operation speed 3~4 times/s <Phase $\pm$ 4, $\pm$ 5 (Fig-5)> (Passing time between 3.5V and 1.5V) $\pm$ 4, $\pm$ 5: 10 ms max.
5.4.2	Contact resistance	Measurement the contact resistance between COM and SW when push SW is ON. Applying force: 8.5N 100m $\Omega$ max.
5.4.3	Insulation resistance	Measurement shall be made under the condition which a voltage of 250V D.C. is applied between individual terminals and a shaft. 50M $\Omega$ min.
5.4.4	Withstand voltage	A voltage of 300V A.C. shall be applied for 1min. between individual terminals and a shaft. Without arcing or breakdown.

Classification

# PROVISIONAL SPECIFICATIONS

Issue No.

RV-V-EVE-0087

Part Name

11mm GS Encoder

Part No.

EVEUPCAH508B

6 / 9

### Phase difference.

(Fig-1)

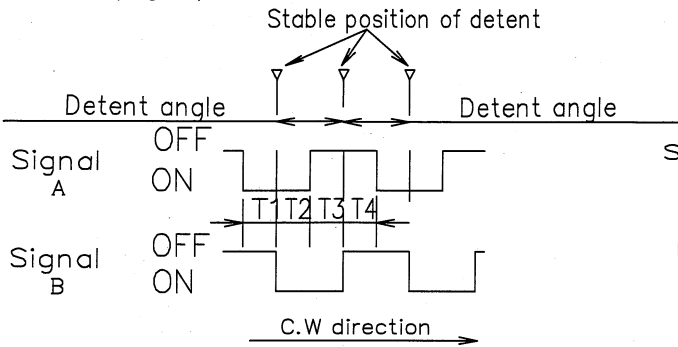

### Measurement circuit diagram.

(Fig-2)

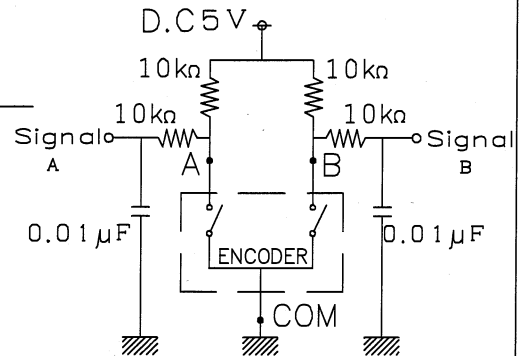

At each detent position, output between COM and A is stable ON or OFF. (Output between COM and B is not specified.)

### Bouncing phase(Fig-3)

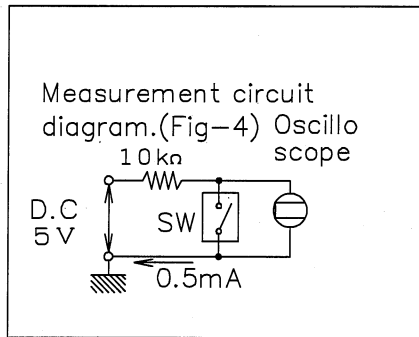
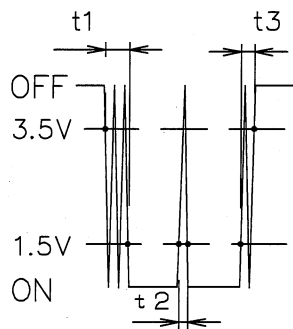

### Bouncing phase(Fig-5)

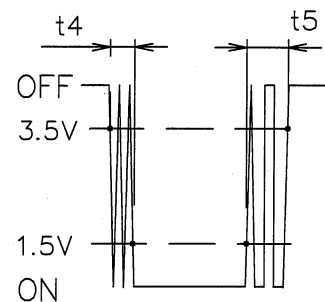

### Encoder terminal layout and switch circuit diagram.

(Fig-6)

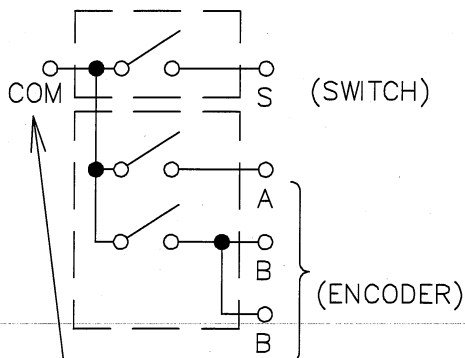

(Notice)

Common terminal is shared between encoder and switch

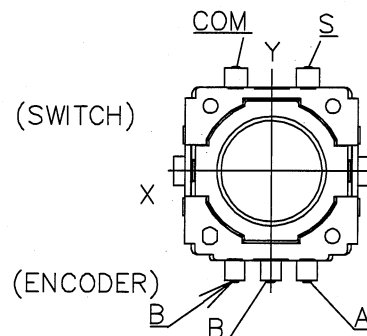

- ENCODER: A : Output signal A
- ENCODER: B : Output signal B
- SWITCH: S : Output signal for switch

Classification	PROVISIONAL SPECIFICATIONS		Issue No.
Part Name	11mm GS Encoder	Part No.	RV-V-EVE-0087
		EVEUPCAH508B	7 / 9

### 5.5 Durability performance

Item	Conditions	Specifications
5.5.1 Rotation life (Encoder)	The shaft of encoder shall be rotated to 30,000 cycles at a speed of 600 to 1000 cycles/h in room temp(15°C to 35°C) without electrical load after which measurements shall be made.	Rotation torque: Initial torque $\pm 80\%$ Phase-difference: 2.5 ms min. Contact resistance: 100 $\Omega$ max. Clause 5.3.4, 5.3.5, 5.3.7, 5.3.8 be conformed
5.5.2 Push operating life (Switch)	Apply 8.5N push strength to shaft to the switch operating direction. The shaft of encoder shall be pushed to 30,000 times at a speed of 2500 times/h in room temp(15°C to 35°C) without electrical load after which measurements shall be made.	Operation force: Initial operation force $\pm 50\%$ Contact resistance: 200m $\Omega$ max. Clause 5.2.3, 5.4.1, 5.4.3, 5.4.4 be conformed
5.5.3 Heat temperature	The encoder shall be stored at a temperature of 85 $\pm 3^\circ\text{C}$ for 240 $\pm 10\text{h}$ in a thermostatic chamber. And then the encoder shall be subjected to standard atmospheric conditions for 1.5h after which measurements shall be made. (Without electrical load)	Contact resistance: 100 $\Omega$ max.
5.5.4 Humidity	The encoder shall be stored at a temperature of 60 $\pm 3^\circ\text{C}$ with relative humidity of 90% to 95% for 240 $\pm 10\text{h}$ in a thermostatic chamber. And then the encoder shall be subjected to standard atmospheric conditions for 1.5h after which measurements shall be made. (Without electrical load)	SW Contact resistance: 200 m $\Omega$ max. Clause 5.1.4, 5.2.2, 5.3.4 to 5.3.8, 5.4.1, 5.4.3, 5.4.4 be conformed
5.5.5 Low temperature	The encoder shall be stored at a temperature of -40 $\pm 3^\circ\text{C}$ for 240 $\pm 10\text{h}$ in a thermostatic chamber. And then the encoder shall be subjected to standard atmospheric conditions for 1.5h after which measurements shall be made. (Without electrical load)	



Classification	PROVISIONAL SPECIFICATIONS		Issue No. RV-V-EVE-0087
Part Name 11mm GS Encoder	Part No. EVEUPCAH508B	8 / 9	

6.Packing:

- (1)Package style : Card bord box.(250pcs./pack)
- (2)Package size : W:160 X L:260 X H:130
- (3)Tray style : Plastic tray.(50pcs./tray)
- (4)Tray size : W:150 X L:248 X H:25

Carton Box Size

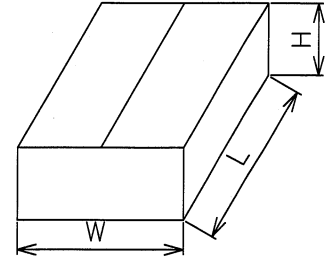

Packing Tray Configuration

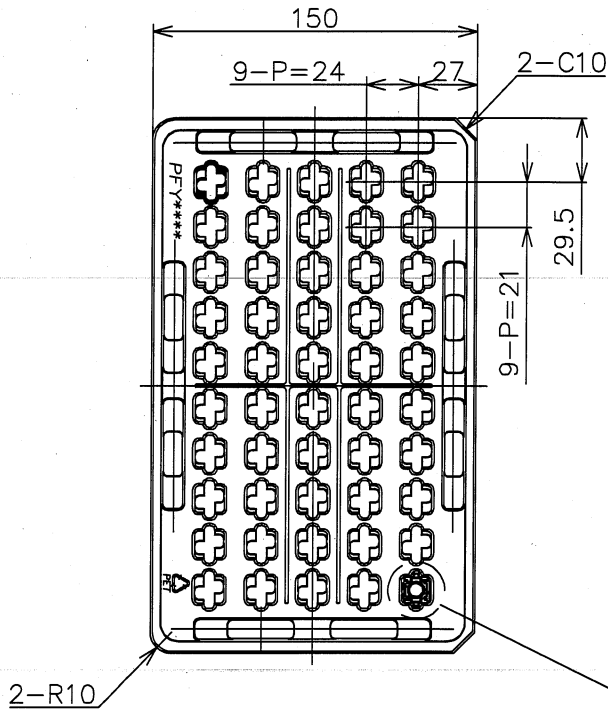

Take out direction.

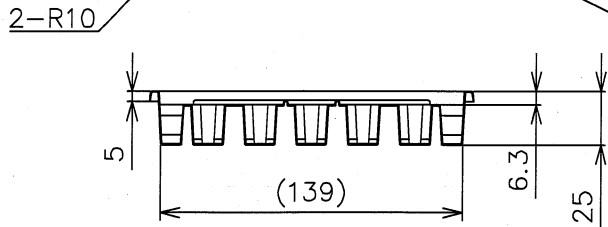
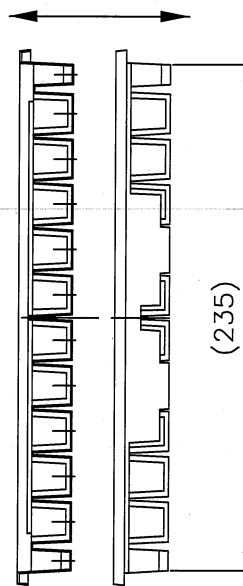

Details of Cavity  
Product Direction

