

THIRD ANGLE PROJECTION

ALL DIMENSIONS ARE IN MILLIMETERS.

DO NOT SCALE DRAWING

General dimension toleranace :  $\pm 0.5$  ( ):Reference dimension

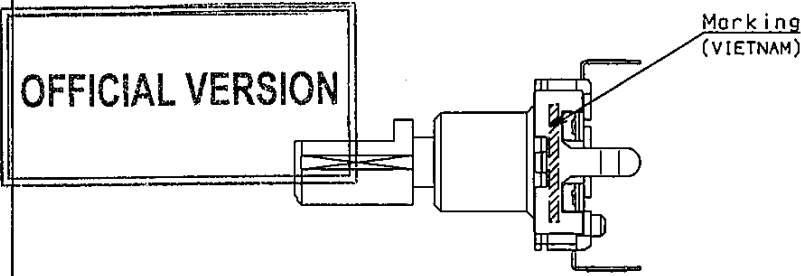
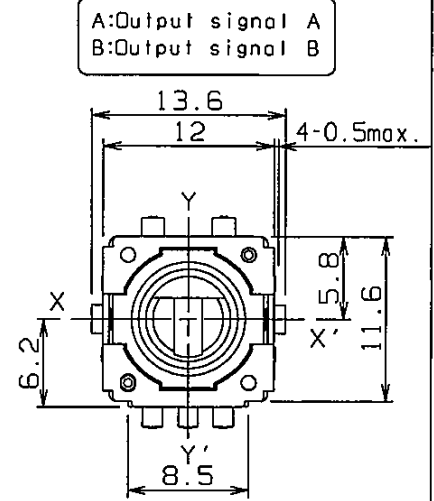
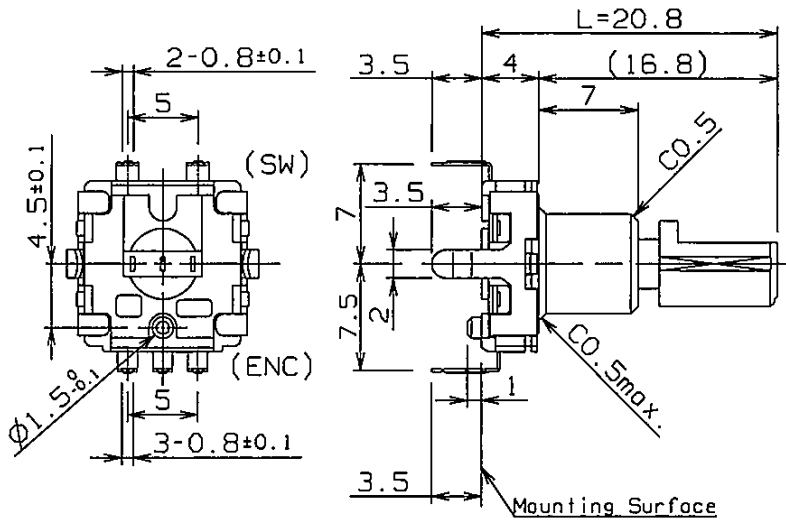

Shaft shape and dimension

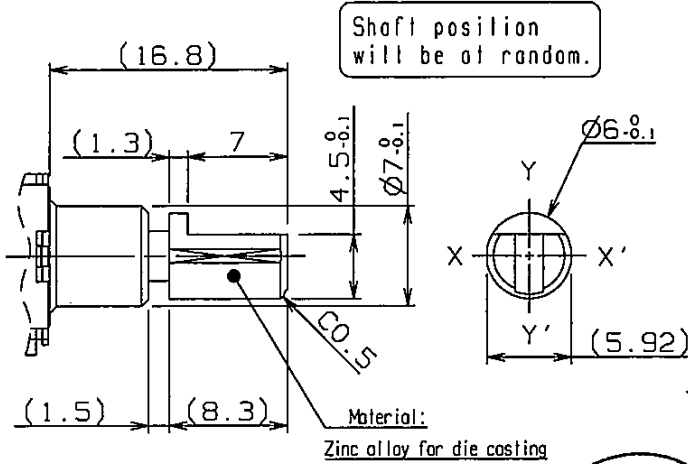

Material:  
Zinc alloy for die casting

P.W.B. piercing plan.

P.W.B thickness  $t=1.6$   
(Tolerance :  $\pm 0.1$ )  
(View from mounting side)

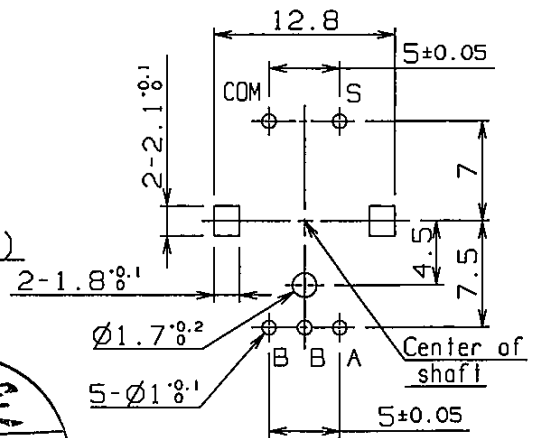

DESIGN	A.Matsumoto	Mar.18.2013	NAME	11mm GS ENCODER	ISSUE	REVISIONS	DATE
DRAW			TYPE NO.	EVEVGHFL816B	DRAWING NO.	RV-H-1775	1/7
CHECK							
APPROVAL	<i>M.Amano</i>	Mar.20.2013					

## General

1. Scope: This specification applies to rotary encoder (incremental type) used in electronic equipment.
2. Standard atmospheric conditions: Unless otherwise specified, The standard range of atmospheric conditions for making measurements and tests is as follows.
  - Ambient temperature : 15°C ~ 35°C
  - Relative humidity : 25% ~ 75%
  - Air pressure : 86kPa ~ 106kPa
3. Operating temperature range : -40°C ~ +85°C
4. Storage temperature range : -40°C ~ +85°C
5. Rated voltage : Encoder D.C 10V  
Switch D.C 16V
6. Rated current : Encoder D.C 1mA  
Switch D.C 20mA

Production country : VIETNAM  
Marked on package label as "MADE IN VIETNAM"

## Mechanical characteristics

Item		Conditions	Specifications
1	Rotation angle		360° (Endless)
2	Detent points		32 detent points
3	Each detent angle		11.25° ±3.0°
4	Rotation torque (Detent torque)	Operating temperature 5°C ~ 85°C	12.0 mN·m ± 6.0 mN·m
		-20°C ~ 5°C	40 mN·m max.
		-40°C ~ -20°C	50 mN·m max.
5	Shaft pull-push strength	Pull and push static load of 100N shall be applied to the shaft in the axial direction for 10 second. (Mount the product to P.W.B.)	Without damage or excessive play in shaft. No excessive abnormality in rotational feeling. And electrical characteristics shall be satisfied.
6	Shaft side-load strength	A momentary load of 0.5 Nm shall be applied at the point 5mm from the tip of the shaft in a direction perpendicular to the axis of shaft for 10 second. (Mount the product to P.W.B.)	Without excessive play or bending in shaft. No excessive abnormality in rotational feeling. And electrical characteristics shall be satisfied.
7	Shaft wobble	A momentary load of 50 mNm shall be applied at the point 2mm from the tip of the shaft in a direction perpendicular to the axis of shaft. (Mount the product to P.W.B.)	0.6xL/30 mm (P-P) max. L : Distance between mounting surface and measuring point on the shaft.
8	Shaft play in rotational wobble	Measure with jig for rotational angle.	2° max. (Initial)

NAME	11mm GS ENCODER	ISSUE	REVISIONS	DATE
TYPE NO.	EVEVGHFL816B	DRAWING NO.	RV-H-1775	2/7

### Electrical characteristics(encoder)

Item		Conditions	Specifications
1	Output signal	(Output of phase difference Fig-1)	A,B 2 signals.
2	Output resolution	Number of pulses in 360° rotation.	16 Pulse / 360°
3	Contact resistance	Measurement shall be stable condition which a output signal is ON condition.	1 $\Omega$ max.
4	Bouncing	Measurement circuit diagram.(Fig-2) At rotational speed 60 min <sup>-1</sup> <Phase t1, t3 (Fig-3)> (Passing time between 3.5V and 1.5V)	t1, t3: 5 ms max.
5	Sliding noise phase t2	Take sliding noise as time in the code-on area between bouncing(t1,t3) and volage change exceed 1.5V.(Fig-3) Rotate shaft at speed 60 $\pm$ 3 min <sup>-1</sup> and measure.	3 ms max.
6	Phase-difference	Measurement shall be made under the condition which the shaft is rotated at 60 min <sup>-1</sup> .	T1, T2, T3, T4 (Fig-1) 4 ms min.
7	Insulation resistance	Measurement shall be made under the condition which a voltage of 250V D.C. is applied between individual terminals and a shaft.	50M $\Omega$ min.
8	Withstand voltage	A volage of 300V A.C. shall be applied for 1min. between individual terminals and a shaft.	Without arcing or breakdown.

### Switch characteristics(switch)

Item		Conditions	Specifications
1	Switch type		Push type S.P.S.T.
2	Contact resistance	Measurement the contact resistance between COM and SW when push SW is ON. Applying force: 7.0N	100m $\Omega$ max.
3	Switch operation force	Measure the max.load until switch turned on when pressing the center of shaft to the operation direction of push SW.	5.0 N $\pm$ 2 N
4	Push stroke	Measure the distance until switch turned on when pressing the center of shaft to the operation direction of push SW.	1.5 mm $\pm$ 0.5 mm (At push force 7.0N)
			1.4 mm $\pm$ 0.4 mm (Travel to ON)
5	Bouncing	Measurement circuit diagram.(Fig-4) At operation speed 3~4 times/s <Phase t4, t5 (Fig-5)> (Passing time between 1.5V and 3.5V)	t4, t5: 10 ms max.
6	Insulation resistance	Measurement shall be made under the condition which a voltage of 250V D.C. is applied between individual terminals and a shaft.	50M $\Omega$ min.
7	Withstand voltage	A volage of 300V A.C. shall be applied for 1min. between individual terminals and a shaft.	Without arcing or breakdown.

NAME	11mm GS ENCODER	ISSUE	REVISIONS	DATE
TYPE NO.	EVEVGHFL816B	DRAWING NO.		
		RV-H- 1775		3/7

Phase difference.

(Fig-1)

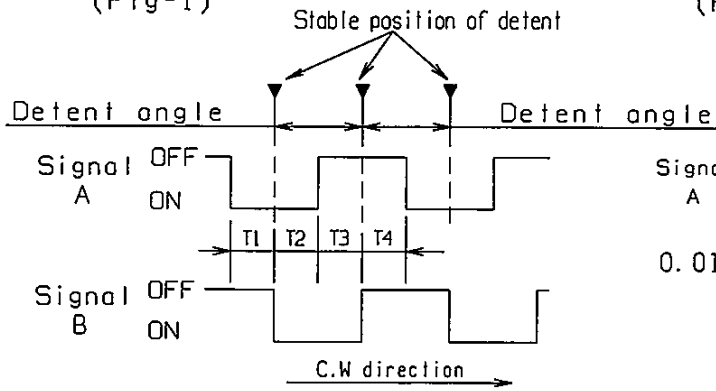

Measurement circuit diagram.

(Fig-2)

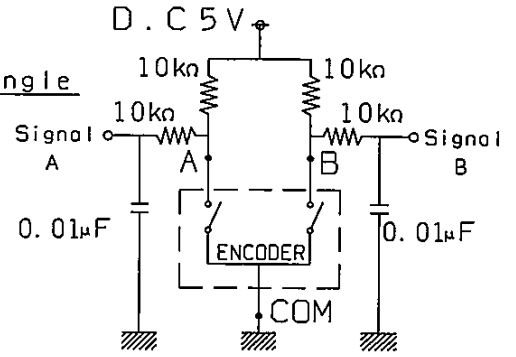

At each detent position, output between COM and A is stable ON or OFF.  
(Output between COM and B is not specified.)

Bouncing phase(Fig-3)

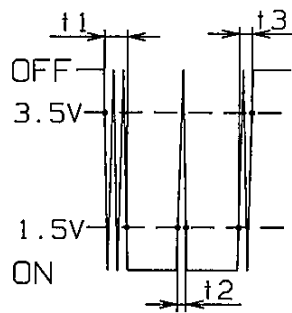

Measurement circuit diagram.(Fig-4)

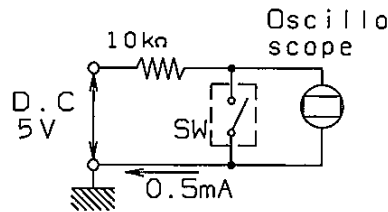

Bouncing phase(Fig-5)

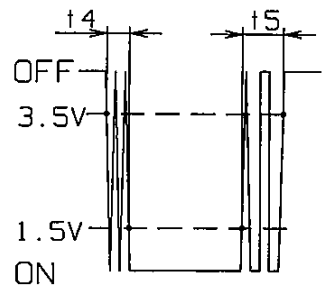

Encoder terminal layout and switch circuit diagram.

(Fig-6)

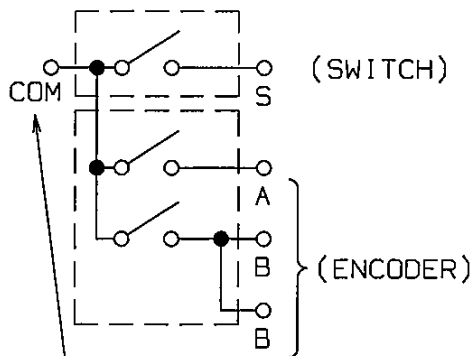

(SWITCH)

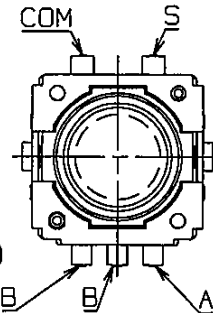

(ENCODER)

ENCODER: A:Output signal A  
B:Output signal B  
SWITCH: S:Output signal for switch

(Notice)

Common terminal is shared between encoder and switch

NAME	11mm GS ENCODER	ISSUE	REVISIONS	DATE
		TYPE NO.	DRAWING NO.	
	EVEVGHFL816B	RV-H- 1775		4/7

## Durability

Item	Conditions	Specifications
1 Rotation life (Encoder)	The shaft of encoder shall be rotated to 30,000cycles at a speed of 600 to 1000 cycles/h in room temp(5°C to 35°C) without electrical load after which measurements shall be made.	Rotation torque: Initial torque $\pm 70\%$ Phase-difference: 2.5 ms min. Contact resistance: 100 $\Omega$ max. Electrical characteristics item: 4,5,7,8 The same as the initial specifications.
2 Push operating life (Switch)	Apply 7.0N push strength to shaft to the switch operating direction. The shaft of encoder shall be pushed to 30,000 times at a speed of 2500 times/h in room temp(5°C to 35°C) without electrical load after which measurements shall be made.	Operation force: Initial operation force $\pm 40\%$ Contact resistance: 200 $\Omega$ max. Switch characteristics item: 4,5,6,7 The same as the initial specifications.
3 Heat temperature	The encoder shall be stored at a temperature of $85\pm 3^\circ\text{C}$ for $240\pm 10\text{h}$ in a thermostatic chamber. And then the encoder shall be subjected to standard atmospheric conditions for 1.5h after which measurements shall be made. (Without electrical load)	Contact resistance: 100 $\Omega$ max.
4 Humidity	The encoder shall be stored at a temperature of $60\pm 3^\circ\text{C}$ with relative humidity of 90% to 95% for $240\pm 10\text{h}$ in a thermostatic chamber. And then the encoder shall be subjected to standard atmospheric conditions for 1.5h after which measurements shall be made. (Without electrical load)	SW Contact resistance: 200 $\Omega$ max. Mechanical characteristics item: 4 Electrical characteristics item: 4,5,6,7,8 Switch characteristics item: 3,4,5,6,7 The same as the initial specifications.
5 Low temperature	The encoder shall be stored at a temperature of $-40\pm 3^\circ\text{C}$ for $240\pm 10\text{h}$ in a thermostatic chamber. And then the encoder shall be subjected to standard atmospheric conditions for 1.5h after which measurements shall be made. (Without electrical load)	

### Packing:

- (1) Package style : Card board box. (500pcs./Packaging)
- (2) Package size : L=374xW=272xH=116
- (3) Tray style : Plastic tray. (100pcs./tray)
- (4) Tray size : L=356xW=260xH=19.4

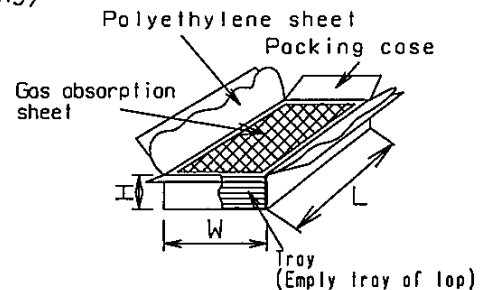

### Marking

1. Date code
2. Output signal

### Handling of approval specification :

1. This specification from specify this item only. Please perform your approval test in the actual equipment conditions beforehand.
2. Writing in this specification from ore subject to change through precoultions.

NAME	11mm GS ENCODER	ISSUE	REVISIONS	DATE
		TYPE NO.	DRAWING NO.	
	EVEVGHFL816B	RV-H- 1775		5/7

**△ Application Notes :**

**1. Prohibited items on fire and smoking**

Absolutely avoid use of a product beyond its rated range because doing so may cause a fire. If misuse or abnormal use may result under conditions in which the product is used out of its rated range, take proper measures such as current interruption using a protective circuit.

The grade of nonflammability for resin used in product is "94HB," which is based on UL94 Standards (flammability test for plastic materials).

Prohibit use in a location where a spreading fire may be generated or prepare against a spreading fire.

**2. For use in equipment for which safety is requested**

Although care is taken to ensure product quality, inferior Characteristics, short circuits, and open circuits are some problems that might be generated. To design a equipment which places maximum emphasis on safety, review the affect of any single fault of a product in advance and perform virtually fail-safe design to ensure maximum safety by:

- Preparing a protective circuit or a protective device to improve system safety, and set
- Preparing a redundant circuit to improve system safety so that the single fault of a product does not cause a dangerous situation.

**3. Reliability**

**Storage condition**

Do not store the product under high temperatures and/or high humidity, or in a location where corrosive gas may be generated.

Store the product at room temperature and room humidity in a packed condition. Use them within a maximum of 6 months.

Check the date of manufacture on the package box and apply the "first-in-first-out" rule.

If unpacked product must be stored as inventory, Store them in polyethylene bag to keep out air.

The encoder's pulse count method should be designed with taking operating speed, sampling time, and the design of the microcomputer software, etc. into consideration.

The item designed mainly corresponds to JIS (Japanese Industrial Standards) on the reliability conditions.

**4. This product does not yet conform to Halogen Free regulation generally required.**

Information of Chemical Substances and Environmental Hazardous Substances.

This product has not been manufactured with ozone depleting chemical controlled under the Montreal Protocol.

This product complies with the RoHS Directive Restriction of the use of certain Hazardous Substance in electrical and electronic equipment DIRECTIVE 2011/65/EU.

All the materials used in the part are registered material under the Law Concerning the Examination and Regulation of Manufacture etc. or Chemical Substances.

Soldering conditions :

Perform the soldering under the conditions shown below.

Soldering conditions (1)

Specific gravity of flux ----- 0.83 ± 0.05

Flux foaming time ----- Within 5 s

Flux foaming level ----- 1/2t or less

Preheating temperature ----- 100 °C max. (Ambient temp.)

Preheating time ----- 70s max.

Soldering should be performed at 260 °C or less within 3 s by twice maximum.

Conditions of P.W.B Thickness Material ----- t=1.6 mm

Double side copper clad phenolic resin Laminates.

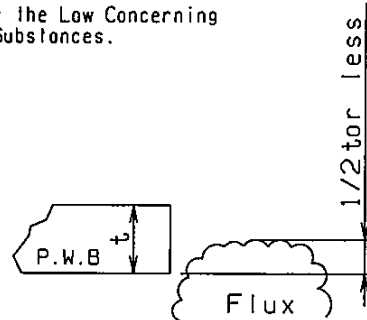

Soldering conditions (2)

<Soldering iron>

Soldering iron : 20W or lower.

Temperature at the iron tip : 350°C or lower.

The duration to apply the soldering iron : 3 seconds or lower. (1 time)

PWB design - When you design mounting hole of PWB, please refer to its dimension defined in this specification.

Particularly, care should be taken in the case of wiring such as jumper wire near the product body where flux is delating.

If flux is spattered to the product body, it may cause electrical contact or sliding trouble.

NAME 11mm GS ENCODER	ISSUE	REVISIONS	DATE
	TYPE NO. EVEVGHFL816B	DRAWING NO. RV-H- 1775	6/7