



# EVK-R4

## SARA-R4 series cellular evaluation kits

### User guide



#### Abstract

This guide explains how to set up the EVK-R4 evaluation kits to begin evaluating the u-blox SARA-R4 series cellular modules supporting multi-band LTE-M / NB-IoT / EGPRS radio access technology.

# Document information

<b>Title</b>	<b>EVK-R4</b>	
<b>Subtitle</b>	SARA-R4 series cellular evaluation kits	
<b>Document type</b>	User guide	
<b>Document number</b>	UBX-16029216	
<b>Revision and date</b>	R08	08-Jul-2021
<b>Disclosure restriction</b>	C1-Public	

<b>Product status</b>	<b>Corresponding content status</b>	
<b>Functional sample</b>	Draft	For functional testing. Revised and supplementary data will be published later.
<b>In development / Prototype</b>	Objective specification	Target values. Revised and supplementary data will be published later.
<b>Engineering sample</b>	Advance information	Data based on early testing. Revised and supplementary data will be published later.
<b>Initial production</b>	Early production information	Data from product verification. Revised and supplementary data may be published later.
<b>Mass production / End of life</b>	Production information	Document contains the final product specification.

This document applies to the following products:

<b>Product name</b>	<b>Type number</b>	<b>Modem version</b>	<b>Application version</b>	<b>PCN reference</b>	<b>Product status</b>
EVK-R410M	EVK-R410M-02B-00	L0.0.00.00.05.12	A.02.19	UBX-20058104	Initial production
	EVK-R410M-52B-00	L0.0.00.00.06.08	A02.11	UBX-20033274	Obsolete
	EVK-R410M-6-00	L0.08.12	A.01.12	UBX-20053055	Initial production
	EVK-R410M-7-00	L0.08.12	A.01.12	UBX-20049254	Initial production
	EVK-R410M-8-00	L0.08.12	A.01.12	UBX-20049255	Initial production
EVK-R412M	EVK-R412M-02B-00	M0.12.00	A.02.19	UBX-20058105	Initial production
EVK-R422M8S	EVK-R422M8S-0-00	00.12	A00.00	UBX-21016086	Initial production

u-blox or third parties may hold intellectual property rights in the products, names, logos and designs included in this document. Copying, reproduction, modification or disclosure to third parties of this document or any part thereof is only permitted with the express written permission of u-blox.

The information contained herein is provided "as is" and u-blox assumes no liability for its use. No warranty, either express or implied, is given, including but not limited to, with respect to the accuracy, correctness, reliability and fitness for a particular purpose of the information. This document may be revised by u-blox at any time without notice. For the most recent documents, visit [www.u-blox.com](http://www.u-blox.com).

Copyright © u-blox AG.

# Contents

Document information.....	2
Contents .....	3
1 Starting up.....	4
Appendix .....	18
A Setting up AT terminal applications for communication with the EVK-R4.....	18
B Setting up a cellular packet data connection on a Windows PC.....	19
C Examples of AT commands .....	24
D Current consumption measurement.....	26
E Glossary .....	28
Declaration of conformities.....	29
Related documentation .....	30
Revision history .....	30
Contact.....	31

# 1 Starting up

## 1.1 EVK-R4 overview

The EVK-R4 kit is a powerful and easy-to-use tool that simplifies the evaluation of the u-blox SARA-R4 series multi-band LTE-M / NB-IoT / EGPRS cellular modules.

The following evaluation kits are available with u-blox SARA-R4 cellular modules:

- The EVK-R410M evaluation kit is for evaluation of SARA-R410M modules, and more specifically:
  - The EVK-R410M-02B evaluation kit is for the SARA-R410M-02B module product version
  - The EVK-R410M-52B evaluation kit is for the SARA-R410M-52B module product version
  - The EVK-R410M-6 evaluation kit is for the SARA-R410M-63B module product version
  - The EVK-R410M-7 evaluation kit is for the SARA-R410M-73B module product version
  - The EVK-R410M-8 evaluation kit is for the SARA-R410M-83B module product version
- The EVK-R412M evaluation kit is for evaluation of SARA-R412M modules
- The EVK-R422M8S evaluation kit is for evaluation of SARA-R422M8S modules

All the evaluation kits are identified herein as the EVK-R4.

 See the SARA-R4 series data sheet [\[2\]](#) and the SARA-R4 series system integration manual [\[3\]](#) for the features supported by the u-blox SARA-R4 series cellular modules.

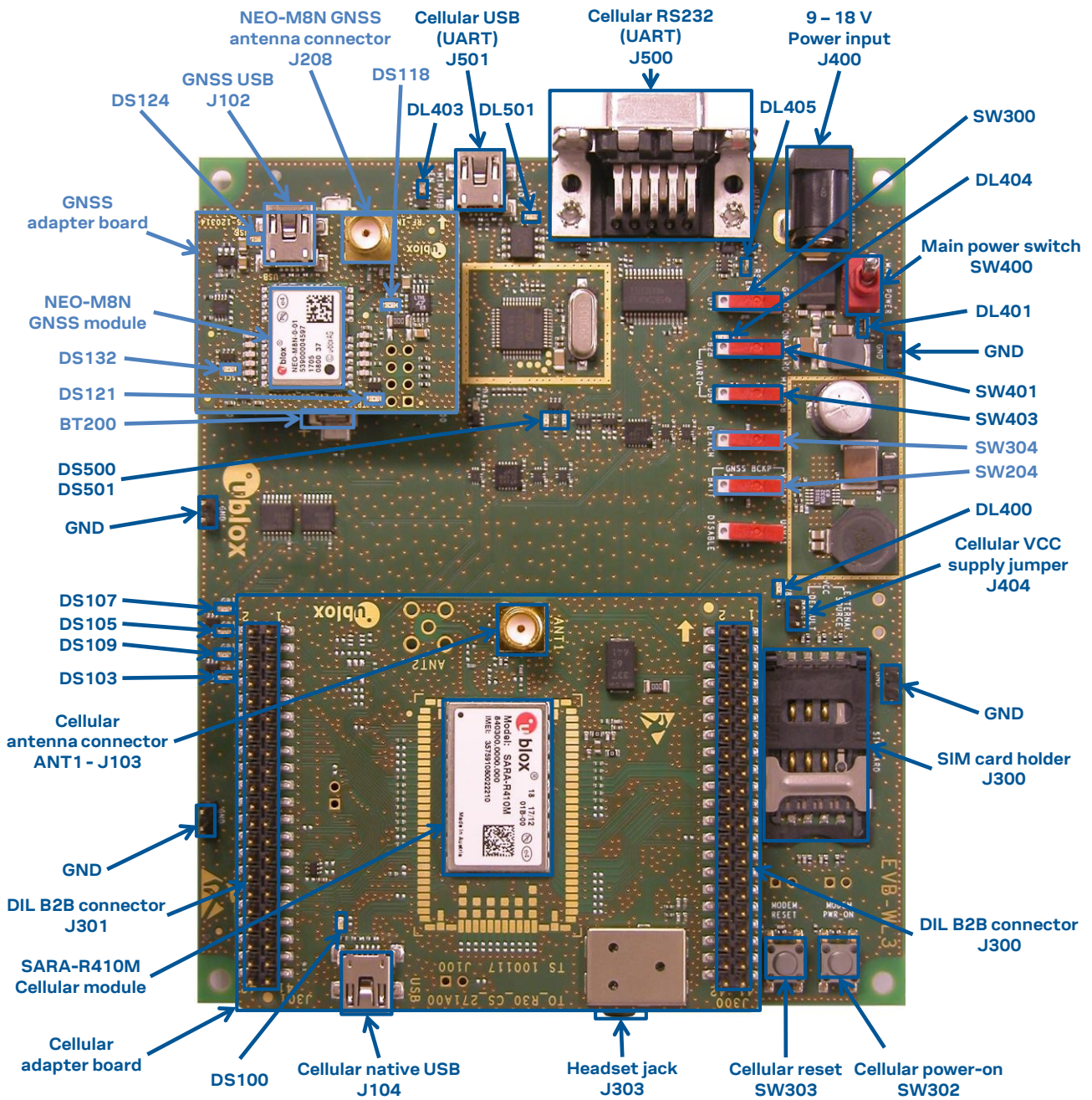

Figure 1: Overview of the EVK-R410M evaluation kit for SARA-R410M modules

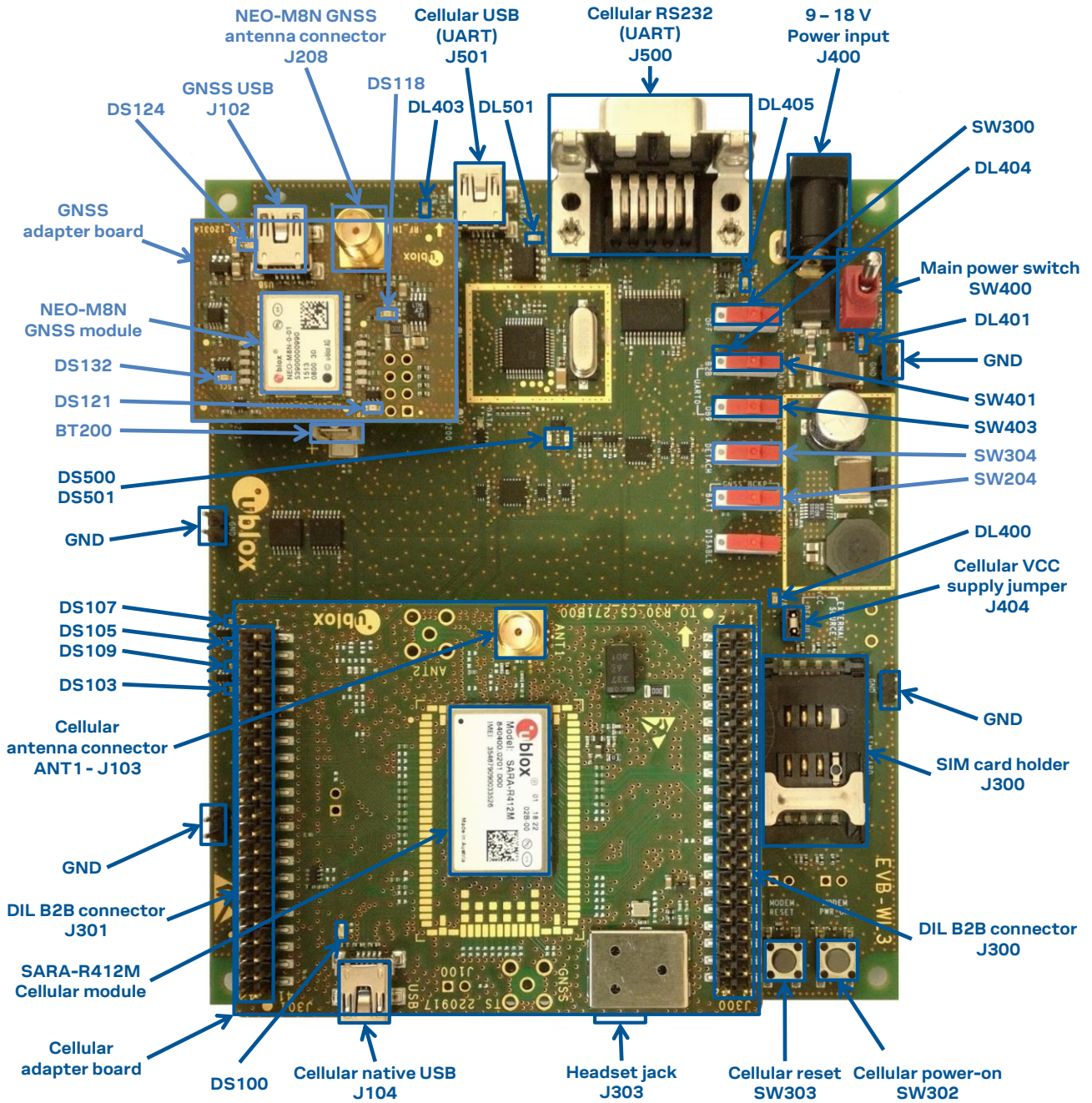

Figure 2: Overview of the EVK-R412M evaluation kit for SARA-R412M modules

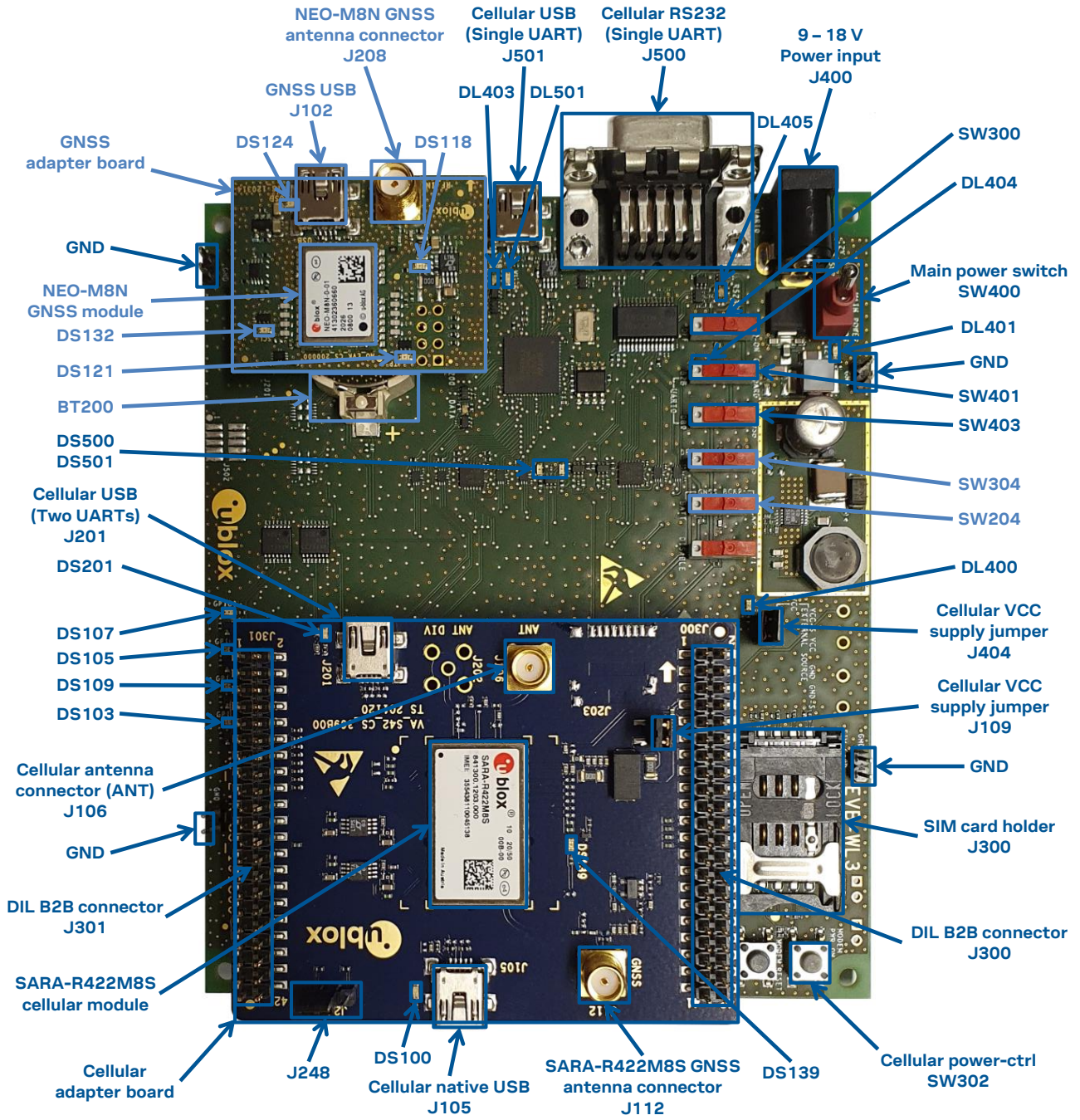

Figure 3: Overview of the evaluation kit for SARA-R422M8S modules

## 1.2 EVK-R4 block diagram

Figure 4 shows the main interfaces and internal connections of the evaluation kit for SARA-R410M and SARA-R412M modules:

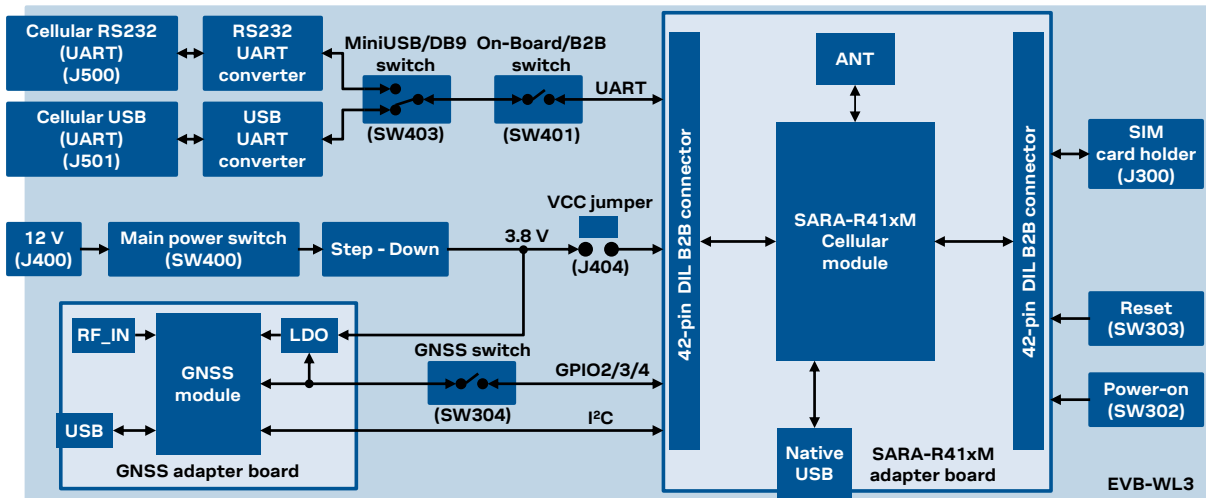

Figure 4: Block diagram of the evaluation kit for SARA-R410M and SARA-R412M modules

Figure 5 shows the main interfaces and internal connections of the evaluation kit for SARA-R422M8S modules:

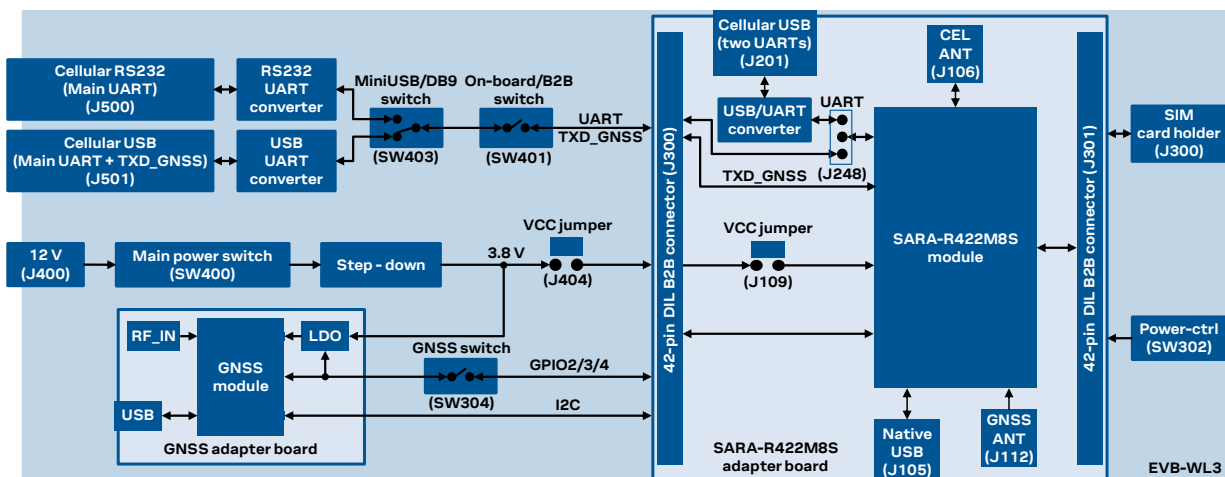

Figure 5: Block diagram of the evaluation kit for SARA-R422M8S modules

The EVK-R4 is formed by three boards:

1. The lower one, called EVB-WL3, contains the power supply and other peripherals for the SARA-R4 series cellular module (SIM card holder, reset button and power-on / power-ctrl button).
2. The cellular adapter board, called ADP-R4, contains the SARA-R4 cellular module, antenna connectors for the cellular RF interface and the GNSS RF interface<sup>1</sup> of the SARA-R4 module, USB connectors for the two UART interfaces<sup>1</sup> and the USB interface of the SARA-R4 module, and the DIL header connectors (J300 and J301) making accessible interfaces of the SARA-R4 module.
3. The GNSS adapter board, called ADP-GNSS, contains the u-blox NEO-M8N GNSS module, the GNSS antenna connector and the USB connector for the u-blox NEO-M8N GNSS module.

<sup>1</sup> EVK-R422M8S only.



The cellular and the GNSS adapter boards are connected by means of male header board-to-board connectors provided on the bottom of the adapter boards and their corresponding female connectors provided on top of the lower board, called EVB-WL3.

### 1.2.1 Specifics to the EVK for SARA-R42 series modules

If the on-board / B2B switch (SW401) on the EVB-WL3 board is set to “on-board”, and if a jumper socket is inserted on the pin 1 and pin 2 of the 3-pin header J248 on the cellular adapter board (see [Figure 6](#)), then the main UART interface of the SARA-R4 module, routed through the DIL header board-to-board connectors mounted on the bottom of the cellular adapter board, can be accessed as converted to USB interface on the USB connector (J501) on the EVB-WL3 board, or it can be accessed as converted to RS232 interface on the RS232 DB9 connector (J500) on the EVB-WL3 board according to the mini-USB / DB9 switch (SW403) settings.

If the on-board / B2B switch (SW401) on the EVB-WL3 board is set to “B2B” and if there is no jumper socket inserted on the 3-pin header J248 on the cellular adapter board (illustrated in [Figure 6](#)), then the UART interface(s) of the SARA-R4 module can be accessed at 1.8V CMOS signal levels on the DIL header connector mounted on the top of the cellular adapter board, to communicate, for example, with an external MCU.

If the on-board / B2B switch (SW401) on the EVB-WL3 board is set to “B2B” and if a jumper socket is inserted on the pin 2 and 3 of the 3-pin header cellular UART jumper (J248) on the adapter board (illustrated in [Figure 6](#)), the UART interfaces of SARA-R42 series module can be accessed as USB interface on the USB connector (J201) on the cellular adapter board.

The UART data output of the internal GNSS system of SARA-R422M8S modules (TXD\_GNSS line) can be accessed as USB interface on the USB connector (J501) on the EVB-WL3 board.

The USB interface of the cellular module (supporting only FW update and diagnostic capability on SARA-R42 series) is available on the native USB connector (J105) on the cellular adapter board.

Other SARA-R4 series peripherals are available on the dual-in-line male board-to-board connectors provided on the top layer of the cellular adapter board.

The lower board (EVB-WL3) is designed to also be used with other u-blox cellular adapter boards. It contains additional switches, jumpers, connectors, LEDs and parts that are only partially described in [Figure 1](#), [Figure 2](#), and in [Figure 3](#) of this document, because they are intended for use only with other u-blox cellular modules. It is recommended to leave any additional connector unconnected, and to leave any additional switch in its default configuration.

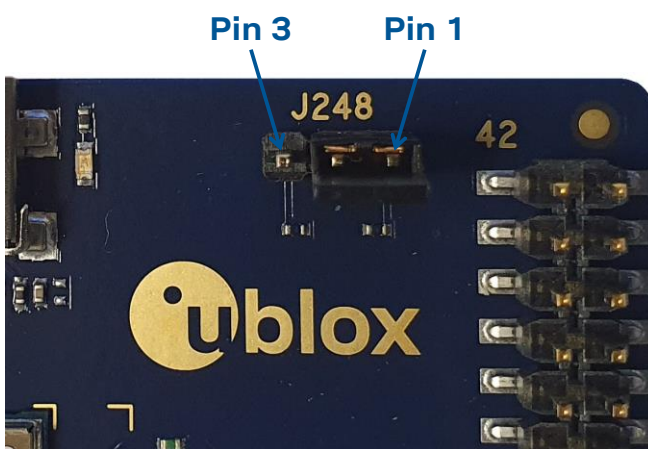















**Figure 6:** 3-pin header J248 available to set the routing of the UART interfaces on the EVK for SARA-R42 series modules.

## 1.3 Switches, jumpers and buttons

Function	Description	Name	Board
Main power switch	Power on / off of the whole evaluation kit	SW400	EVB
Cellular VCC	Jumper socket to provide the 3.8 V supply to the cellular module VCC input	J404	EVB
		J109	ADP-R42
Cellular power on	Push button to switch on / off SARA-R410M /-R412M modules	SW302	EVB
	Push button to switch on / off / reset SARA-R422M8S modules		
Cellular reset	Push button to abrupt switch off the SARA-R410M /-R412M modules	SW303	EVB
Cellular UART detach	Slide switch to attach / detach the cellular module main primary UART from the USB / RS232 connectors on EVB-WL3	SW401	EVB
Cellular UART routing	Slide switch to select cellular module main primary UART routing on the USB or RS232 connector on EVB-WL3	SW403	EVB
Cellular UART routing	3-pin header to route and make accessible the UART(s) of SARA-R42 modules over the USB connector on the ADP board, or over the USB or RS232 connectors on the EVB-WL3, or over the DIL B2B connector on the top of the ADP board	J248	ADP-R42
Cellular GPIO detach	Slide switch to attach / detach the cellular module GPIOs from peripherals: when detached, the signals are available only on the DIL B2B connector on the ADP board	SW300	EVB
Cellular GNSS detach <sup>2</sup>	Slide switch to attach / detach the cellular module to / from the GNSS module (GPIO2-3-4): when detached, the signals are available only on the DIL B2B connector on the ADP board	SW304	EVB
GNSS V_BCKP	Slide switch to connect / disconnect backup battery to / from the V_BCKP pin of the GNSS module	SW204	EVB

Table 1: EVK-R4 switch and button descriptions

## 1.4 LEDs

Function	Description	LED #	Board	Color
Main power	Power supply plugged in the <b>9 - 18 V Power Input</b>	DL401	EVB	
Cellular VCC	Cellular module supplied. <b>Main power switch</b> must be switched on	DL400	EVB	
Cellular USB (main UART)	USB cable plugged in the <b>Cellular USB</b> connector (J501) for access to the main UART interface of cellular module	DL501	EVB	
Cellular USB (main UART)	Green light is on when the SW401 is in “on-board” position, and when the cellular module main UART is routed to the <b>Cellular USB</b> connector Red light blinks at UART TX or RX data on the <b>Cellular USB</b> connector	DL403	EVB	
Cellular main UART attach/detach	UART signals of the cellular module are available only on the ADP board.	DL404	EVB	
Cellular RS232 (main UART)	Green light is on when the main UART of the cellular module is routed to the <b>Cellular RS232</b> connector (J500) Red light blinks at UART TX / RX data on the <b>Cellular RS232</b> connector	DL405	EVB	
Cellular RI indicator	RI line turns ON (active low)	DS501	EVB	
Cellular CTS indicator	CTS line turns ON (active low)	DS500	EVB	
Cellular GPIO1 indicator	Green light is activated when cellular GPIO1 is high	DS107	EVB	
Cellular GPIO2 indicator	Green light is activated when cellular GPIO2 is high	DS105	EVB	
Cellular GPIO3 indicator	Green light is activated when cellular GPIO3 is high	DS109	EVB	
Cellular GPIO4 indicator	Green light is activated when cellular GPIO4 is high	DS103	EVB	
SARA GNSS Timepulse	SARA-R422M8S GNSS TimePulse output	DS139	ADP-R42	
Cellular native USB	USB cable plugged in the <b>Cellular native USB</b> connector (J104 / J105) on the ADP-R4, for access to the USB interface of cellular module	DS100	ADP-R4x	

<sup>2</sup> For EVK-R422M8S it is recommended to keep this switch on “detach” position.



Function	Description	LED #	Board	Color
Cellular USB (two UARTs)	USB cable plugged in the <b>Cellular USB</b> connector (J201) on the ADP-R4, for access to the two UART interfaces of SARA-R422M8S	DS201	ADP-R42	
GNSS VCC supply	NEO-M8N GNSS module supply is turned ON	DS118	ADP-GNSS	
GNSS USB	USB cable plugged into the <b>GNSS USB</b> connector for NEO-M8N	DS124	ADP-GNSS	
NEO GNSS Timepulse	NEO-M8N GNSS TimePulse output	DS121	ADP-GNSS	
Cellular / GNSS I2C	Cellular / GNSS module communication over the DDC (I2C) interface	DS132	ADP-GNSS	

**Table 2: EVK-R4 LED descriptions**

## 1.5 Connectors

Function	Description	Name	Board
9 - 18 V Power Input	Connector for the AC / DC power adapter of the EVK  IEC 60417-5172 Class II equipment AC: 100-240 V, 0.8 A, 50-60 Hz / DC: +12 V, 2.5 A	J400	EVB
SIM card holder	SIM card holder	J300	EVB
Cellular USB (main UART)	Mini USB connector for the cellular module main UART interface converted as a USB interface	J501	EVB
Cellular RS232 (main UART)	DB9 connector for the cellular module main UART interface converted as an RS232 interface	J500	EVB
Cellular antenna	SMA connector for the cellular module antenna (ANT, Tx/Rx)	J106	ADP-R42
		J103	ADP-R41
GNSS antenna (for SARA-R422M8S)	SMA connector for the GNSS antenna to be connected to the GNSS RF input of the SARA-R422M8S module (ANT_GNSS)	J112	ADP-R42
Cellular native USB	Mini USB connector for the cellular module native USB interface	J105	ADP-R42
		J104	ADP-R41
Cellular USB (two UARTs)	Mini USB connector for the two UART interfaces of the SARA-R422M8S module converted as a USB interface	J201	ADP-R42
DIL B2B headers	Dual-in-line board-to-board connectors for cellular module interfaces	J300, J301	ADP-R4x
GNSS antenna (for NEO-M8N)	SMA connector for the GNSS antenna to be connected to the GNSS RF input of the NEO-M8N GNSS module (RF_IN)	J208	ADP-GNSS
GNSS USB	Mini USB connector for the GNSS module USB interface	J102	ADP-GNSS
GNSS backup battery	Backup battery socket for the GNSS module (under GNSS adapter board)	BT200	EVB
Cellular headset	Audio headset jack connector for the cellular module audio interface	J303	EVB
GND	Ground terminals for the probe reference	J402, J403 J405, J406	EVB

**Table 3: EVK-R4 connector descriptions**

-  **Caution!** In the unlikely event of a failure in the internal protection circuitry, there is a risk of explosion when charging a fully or partially discharged battery. Replace the battery when it no longer has a sufficient charge for unit operation. Control the battery before use if the device has not been used for an extended period.
-  **Caution!** Risk of explosion if the battery is replaced with an incorrect type. Dispose of used batteries according to the instructions!

## 1.6 EVK-R410M pin out

SARA-R410M		DIL B2B		SARA-R410M		DIL B2B	
Pin N°	Name	Name / Pin N°	Pin N°	Name	Name / Pin N°	Pin N°	Name
1	GND	J301 pins 7-8-9-10	33	RSVD	Not available		
2	RSVD	J301 pin 3	34	I2S_WA	Not available		
3	GND	J301 pins 7-8-9-10	35	I2S_TXD	Not available		
4	V_INT	J301 pin 36	36	I2S_CLK	Not available		
5	GND	J301 pins 7-8-9-10	37	I2S_RXD	Not available		
6	DSR	J301 pin 18	38	SIM_CLK	J300 pin 15		
7	RI	J301 pin 17	39	SIM_IO	J300 pin 14		
8	DCD	J301 pin 11	40	SIM_RST	J300 pin 16		
9	DTR	J301 pin 12	41	VSIM	J300 pin 13		
10	RTS	J301 pin 13	42	GPIO5	J301 pin 23		
11	CTS	J301 pin 14	43	GND	J301 pins 7-8-9-10		
12	TXD	J301 pin 15	44	SDIO_D2	J301 pin 30		
13	RXD	J301 pin 16	45	SDIO_CLK	J300 pin 19		
14	GND	J301 pins 7-8-9-10	46	SDIO_CMD	J300 pin 18		
15	PWR_ON	J301 pin 29	47	SDIO_D0	J300 pin 17		
16	GPIO1	J301 pin 33	48	SDIO_D3	J301 pin 39		
17	VUSB_DET	Not available	49	SDIO_D1	J301 pin 37		
18	RESET_N	J300 pin 26	50	GND	J301 pins 7-8-9-10		
19	GPIO6	Not available	51	VCC	J300 pins 7-8-9-10		
20	GND	J301 pins 7-8-9-10	52	VCC	J300 pins 7-8-9-10		
21	GND	J301 pins 7-8-9-10	53	VCC	J300 pins 7-8-9-10		
22	GND	J301 pins 7-8-9-10	54	GND	J301 pins 7-8-9-10		
23	GPIO2	J301 pin 31	55	GND	J301 pins 7-8-9-10		
24	GPIO3	J301 pin 32	56	ANT	Not available		
25	GPIO4	J301 pin 25	57	GND	J301 pins 7-8-9-10		
26	SDA	J300 pin 21	58	GND	J301 pins 7-8-9-10		
27	SCL	J300 pin 20	59	GND	J301 pins 7-8-9-10		
28	USB_D-	Not available	60	GND	J301 pins 7-8-9-10		
29	USB_D+	Not available	61	GND	J301 pins 7-8-9-10		
30	GND	J301 pins 7-8-9-10	62	ANT_DET	Not available		
31	RSVD	Not available	63	GND	J301 pins 7-8-9-10		
32	GND	J301 pins 7-8-9-10	64	GND	J301 pins 7-8-9-10		

**Table 4: Interfaces of the SARA-R410M module, as routed on the 42-pin dual-in-line board-to-board connectors (J300, J301) available on the adapter board ADP-R410M of the EVK-R410M evaluation kit**

 The pins / interfaces that are not supported by a specific SARA-R4 product version should not be driven by an external device (see the SARA-R4 series data sheet [2] and the SARA-R4 series system integration manual [3] for features supported by each SARA-R4 module product version).

## 1.7 EVK-R412M pinout

SARA-R412M		DIL B2B		SARA-R412M		DIL B2B	
Pin N°	Name	Name / Pin N°	Pin N°	Name	Name / Pin N°	Pin N°	Name
1	GND	J301 pins 7-8-9-10	33	RSVD	Not available		
2	RSVD	J301 pin 3	34	I2S_WA	Not available		
3	GND	J301 pins 7-8-9-10	35	I2S_TXD	Not available		
4	V_INT	J301 pin 36	36	I2S_CLK	Not available		
5	GND	J301 pins 7-8-9-10	37	I2S_RXD	Not available		
6	DSR	J301 pin 18	38	SIM_CLK	J300 pin 15		
7	RI	J301 pin 17	39	SIM_IO	J300 pin 14		
8	DCD	J301 pin 11	40	SIM_RST	J300 pin 16		
9	DTR	J301 pin 12	41	VSIM	J300 pin 13		
10	RTS	J301 pin 13	42	GPIO5	J301 pin 23		
11	CTS	J301 pin 14	43	GND	J301 pins 7-8-9-10		
12	TXD	J301 pin 15	44	SDIO_D2	J301 pin 30		
13	RXD	J301 pin 16	45	SDIO_CLK	J300 pin 19		
14	GND	J301 pins 7-8-9-10	46	SDIO_CMD	J300 pin 18		
15	PWR_ON	J301 pin 29	47	SDIO_D0	J300 pin 17		
16	GPIO1	J301 pin 33	48	SDIO_D3	J301 pin 39		
17	VUSB_DET	Not available	49	SDIO_D1	J301 pin 37		
18	RESET_N	J300 pin 26	50	GND	J301 pins 7-8-9-10		
19	GPIO6	J301 pin 24	51	VCC	J300 pins 7-8-9-10		
20	GND	J301 pins 7-8-9-10	52	VCC	J300 pins 7-8-9-10		
21	GND	J301 pins 7-8-9-10	53	VCC	J300 pins 7-8-9-10		
22	GND	J301 pins 7-8-9-10	54	GND	J301 pins 7-8-9-10		
23	GPIO2	J301 pin 31	55	GND	J301 pins 7-8-9-10		
24	GPIO3	J301 pin 32	56	ANT	Not available		
25	GPIO4	J301 pin 25	57	GND	J301 pins 7-8-9-10		
26	SDA	J300 pin 21	58	GND	J301 pins 7-8-9-10		
27	SCL	J300 pin 20	59	GND	J301 pins 7-8-9-10		
28	USB_D-	Not available	60	GND	J301 pins 7-8-9-10		
29	USB_D+	Not available	61	GND	J301 pins 7-8-9-10		
30	GND	J301 pins 7-8-9-10	62	ANT_DET	Not available		
31	RSVD	Not available	63	GND	J301 pins 7-8-9-10		
32	GND	J301 pins 7-8-9-10	64	GND	J301 pins 7-8-9-10		

**Table 5: Interfaces of the SARA-R412M module, as routed on the 42-pin dual-in-line board-to-board connectors (J300, J301) available on the adapter board ADP-R412M of the EVK-R412M evaluation kit**

 The pins / interfaces that are not supported by a specific SARA-R4 product version should not be driven by an external device (see the SARA-R4 series data sheet [2] and the SARA-R4 series system integration manual [3] for features supported by each SARA-R4 module product version).

## 1.8 EVK-R422M8S pinout

SARA-R422M8S		DIL B2B connector	SARA-R422M8S		DIL B2B connector
Pin no.	Signal name	Name / pin number	Pin no.	Signal name	Name / pin number
1	GND	J301 pins 7-8-9-10	33	RSVD	J301 pin 36
2	USB_3V3	J301 pin 4	34	I2S_WA	J300 pin 26
3	GND	J301 pins 7-8-9-10	35	I2S_TXD	J300 pin 23
4	V_INT	J301 pin 35	36	I2S_CLK	J300 pin 21
5	GND	J301 pins 7-8-9-10	37	I2S_RXD	J300 pin 24
6	DSR	J301 pin 17	38	SIM_CLK	J300 pin 16
7	RI	J301 pin 18	39	SIM_IO	J300 pin 13
8	DCD	J301 pin 12	40	SIM_RST	J300 pin 15
9	DTR	J301 pin 11	41	VSIM	J300 pin 14
10	RTS	J301 pin 14	42	GPIO5	J301 pin 24
11	CTS	J301 pin 13	43	GND	J301 pins 7-8-9-10
12	TXD	J301 pin 16	44	ANT_ON <sup>3</sup>	J300 pin 4
13	RXD	J301 pin 15	45	TIMEPULSE <sup>3</sup>	J300 pin 1
14	GND	J301 pins 7-8-9-10	46	EXTINT <sup>3</sup>	J300 pin 3
15	PWR_CTRL	J301 pin 30	47	TXD_GNSS <sup>3</sup>	J301 pin 19
16	GPIO1	J301 pin 34	48	RSVD	Not available
17	USB_5V0	Not available	49	RSVD	Not available
18	RSVD	J300 pin 25	50	GND	J301 pins 7-8-9-10
19	GPIO6	J301 pin 23	51	VCC	J300 pins 7-8-9-10
20	GND	J301 pins 7-8-9-10	52	VCC	J300 pins 7-8-9-10
21	GND	J301 pins 7-8-9-10	53	VCC	J300 pins 7-8-9-10
22	GND	J301 pins 7-8-9-10	54	GND	J301 pins 7-8-9-10
23	GPIO2	J301 pin 32	55	GND	J301 pins 7-8-9-10
24	GPIO3	J301 pin 31	56	ANT	Not available
25	GPIO4	J301 pin 26	57	GND	J301 pins 7-8-9-10
26	SDA	J300 pin 22	58	GND	J301 pins 7-8-9-10
27	SCL	J300 pin 19	59	GND	J301 pins 7-8-9-10
28	USB_D-	Not available	60	GND	J301 pins 7-8-9-10
29	USB_D+	Not available	61	GND	J301 pins 7-8-9-10
30	GND	J301 pins 7-8-9-10	62	ANT_DET	Not available
31	ANT_GNSS <sup>3</sup>	Not available	63	GND	J301 pins 7-8-9-10
32	GND	J301 pins 7-8-9-10	64	GND	J301 pins 7-8-9-10

**Table 6: Interfaces of SARA-R422M8S modules, as routed on the 42-pin dual-in-line board-to-board connectors (J300, J301) available on the ADP-R4 adapter board of the EVK-R4 evaluation kit**

 The pins / interfaces that are not supported by a specific SARA-R4 version should not be driven by an external device (see the SARA-R4 series data sheet [2] and the SARA-R4 series system integration manual [3] for features supported by each SARA-R4 module product version).

<sup>3</sup> SARA-R422M8S modules only.

## 1.9 Software installation

The USB drivers for Windows operating systems are available with the EVK-R4. Executable files can be downloaded from [www.u-blox.com/evk-downloads](http://www.u-blox.com/evk-downloads) and saved to any location on the computer hard drive. The installation can be started by running the executable file on a computer with the Windows operating system.

## 1.10 Board setup

1. Insert a SIM card into the **SIM card holder** (J300 on the EVB).
2. Connect the cellular antenna provided with the evaluation kit box to the **Cellular antenna SMA** connector on the ADP-R4 (ANT connector for transmission and reception of LTE RF signals)
3. If the GNSS functionality is required:
  - 3.1. For the EVK-R410M and EVK-R412M, connect the GNSS antenna provided with the evaluation kit box to the **GNSS antenna** SMA connector on the ADP-GNSS (J208); keep the cellular GNSS detach switch (SW304) in “GNSS” position.
  - 3.2. For the EVK-R422M8S, connect the GNSS antenna provided with the evaluation kit box to the **GNSS antenna** SMA connector on the ADP-R422M8S (J112); keep the cellular GNSS detach switch (SW304) in “detach” position.

Place the GNSS antenna in a location with a good view of the sky.



Interface to the NEO-M8N GNSS module is not supported by SARA-R422M8S <sup>4</sup>.

4. Connect the AC / DC +12 V power adapter provided with the evaluation kit box to the **9 – 18 V Power input** connector (J400 on the EVB). The LED DL401 lights blue.
5. Be sure to provide a jumper socket on the **Cellular VCC supply jumpers** (the J404 on the EVB, and the J109 on the ADP-R42). These jumpers provide the connection from the 3.8 V output of the supply circuit on the EVB to the VCC input of the module.
6. To enable the board power supply, turn the **Main power switch** (SW400 on the EVB) to the ON position. The LED DL400 lights green.
7. For communication via the cellular module’s UART interface, the following connections are allowed and can be alternatively enabled in a mutually exclusive way (see [Table 7](#) for the switch position and LED status):
  - 7.1. Connect a USB cable to the mini USB connector on the EVB (**Cellular USB**, J501). The LED DL501 lights blue. When a USB cable is connected to the mini USB connector, two COM ports are enabled in Windows (the numbering of the COM ports can be seen via the Windows Device Manager). The main UART interface is available over the first COM port. The GNSS UART output of SARA-R422M8S is available over the second COM port.
  - 7.2. Connect an RS232 cable to the DB9 connector (**Cellular RS232**, J500 on EVB).
  - 7.3. Connect a USB cable to the mini USB connector on the ADP-R42 (**Cellular USB**, J201). The LED DS201 lights blue. When a USB cable is connected to this mini USB connector, two COM ports are enabled in Windows: the two UART interfaces of the SARA-R42 series modules are respectively available over the two numbered COM ports opened by the driver (to enable the two UART interfaces, see the AT command manual [\[1\]](#), +USIO AT command).

<sup>4</sup> Supply for the NEO-M8N GNSS module can be provided mounting the 0R jumper R106 and removing the 0R jumper R107 on the ADP-GNSS

Type of connections	SW401	SW403	J248	LED
Access to the main UART of SARA-R4 modules, and the GNSS UART output of SARA-R422M8S modules, over the <b>Cellular USB</b> mini USB connector on the EVB-WL3 (J501)	ON BOARD	MINIUSB	Jumper socket on pins 1-2	DL403 DL501
Access to the main UART of SARA-R4 modules over the <b>Cellular RS232</b> DB9 connector on the EVB-WL3 (J500)	ON BOARD	DB9	Jumper socket on pins 1-2	DL405
Access to UART(s) accessible on the DIL Board-to-Board <b>header connector</b> on the top of the adapter board (J301), with UART(s) detached from the mini USB (J501) and RS232 (J500) connectors on EVB-WL3, and detached from the mini USB (J201) connector on the ADP-R42	B2B	Do not care	No jumper socket	DL404
Access to the two UART of SARA-R42 modules over the <b>Cellular USB</b> mini USB connector on the ADP-R42 (J201), with UARTs detached from mini USB (J501) and RS232 (J500) connectors on EVB-WL3	B2B	Do not care	Jumper socket on pins 2-3	DL404 DS201

**Table 7: Serial interface configuration**

Run an AT terminal application (e.g. the u-blox m-center tool), and select the AT COM port with the following settings:

- Data rate: 115,200 bit/s
- Data bits: 8
- Parity: N
- Stop bits: 1
- Flow control: HW

See Appendix A for how to configure the u-blox m-center AT terminal for Windows.

8. To access the cellular module via USB interface, connect a USB cable to the **Cellular native USB** connector on the ADP-R4. The related LED DS100 lights blue.

After the end of modules' boot (refer to point 9 for the procedure to switch-on the cellular module), the ports listed in Table 8 are enabled by the Windows USB driver (details as the numbering of the ports can be seen via the Windows Device Manager):

Type	Remarks
Modems	AT command interface and data communication <sup>5</sup>
Ports (COM & LPT)	Diagnostic purpose

**Table 8: Cellular USB interface configuration**

For AT communication with the SARA-R410M and SARA-R412M modules, run an AT terminal application (e.g. the u-blox m-center tool) and select the AT modem port, with these settings

- Data rate: 115,200 bit/s
- Data bits: 8
- Parity: N
- Stop bits: 1
  - Flow control: HW

See Appendix A for how to configure the u-blox m-center AT terminal for Windows.

9. To switch on the cellular module, press the **Cellular Power-on / Power-ctrl** button (SW302 on the EVB-WL3 board).

<sup>5</sup> SARA-R410M and SARA-R412M modules only



## 1.11 Enabling error result codes

Command sent by DTE (user)	DCE response (module)	Description
AT+CMEE=2	OK	Enables the cellular module to report verbose error result codes.

## 1.12 PIN code insertion (when required)

Command sent by DTE (user)	DCE response (module)	Description
AT+CPIN="8180"	OK	Enter the PIN code, if needed (enter the PIN of the SIM card – 8180 is written here as an example).
AT+CLCK="SC",0,"8180"	OK	Unlock the PIN at power-on (the last parameter is the PIN of the SIM card – 8180 is written here as an example).
AT+CLCK="SC",1,"8180"	OK	Lock the PIN at power-on (the last parameter is the PIN of the SIM card – 8180 is written here as an example).

## 1.13 Registration on a cellular network

Command sent by DTE (user)	DCE response (module)	Description
AT+CEREG?	+CEREG: 0,1 OK	Verify the network registration status.
AT+COPS?	+COPS: 0,0,"Verizon Wireless",7 OK	Read the operator name and radio access technology (RAT).

## 1.14 Switching off the EVK-R4

To switch off the EVK-R4, send the +CPWROFF AT command. Make sure to use this command before switching off the main power, otherwise settings and configuration parameters may not be saved in the internal non-volatile memory of the cellular module.

## Appendix

# A Setting up AT terminal applications for communication with the EVK-R4

The u-blox m-center cellular module evaluation tool is a powerful platform for evaluating, configuring and testing u-blox cellular products. m-center includes an AT commands terminal for communication with the device and can be downloaded free-of-charge from our website (<http://www.u-blox.com>).

1. Follow the board setup instructions in section 1.10 to provide all the required connections and switching on the cellular module.
2. Run the m-center tool: after the m-center start-up, the **Home** page appears.
3. On the **Home** page, set up the AT COM port; for the setting values, see section 1.10. Check with the Windows Device Manager to find out which COM port is being used by the EVK-R4.

4. Enable the connection to the u-blox cellular module by clicking on the **Connect** button.

5. Retrieve the module and network information by clicking on the **Get Info** button.

6. The module information is retrieved and displayed on the Home page.

7. Click on the **AT Terminal** button, found at the upper right of the **Home** page. A new window opens and the AT command terminal is now ready for communication with the EVK-R4.

8. The AT terminal is ready to use. For the complete list of AT commands supported by the modules and their syntax, see the SARA-R4 series AT commands manual [1].

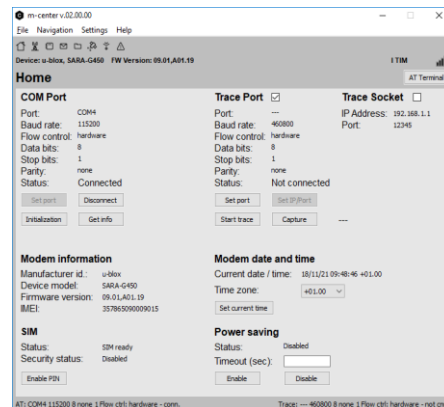

Figure 7: "Home" page

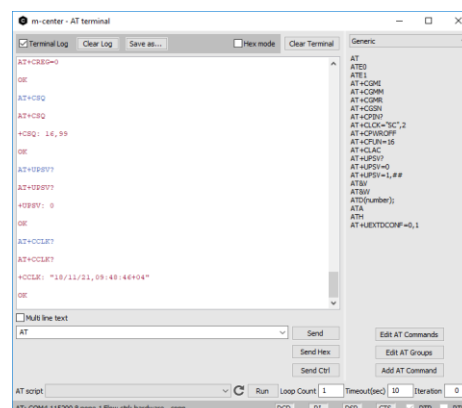

Figure 8: AT terminal window

For more information on using the u-blox m-center cellular module evaluation tool, press the F1 key on the keyboard to open the m-center help window on the computer.

## B Setting up a cellular packet data connection on a Windows PC

This section describes how to set up a packet data connection with the Windows 7 operating systems (for PC) and EVK-R4, using the TCP/IP stack of the PC (external TCP/IP stack).

The following examples describe how to install and configure two different kinds of modem on Windows:

1. Over the UART interface of the cellular module: connect the Windows PC to the **Cellular USB** connector (J501 on EVB) or the **Cellular RS232** connector (J500 on the EVB)
2. Over the native USB interface of SARA-R410M or SARA-R412M module: connect the Windows PC to the **Cellular Native USB** connector (J105 on the ADP)

### B.1 How to install and configure a modem data connection over UART

This example describes how to install and configure a data connection on a PC with the Windows 7 operating system. This uses the TCP/IP stack of the PC over the UART interface of the cellular module connected to the Windows PC by the **Cellular USB** connector (J501 on EVB) or the **Cellular RS232** connector (J500 on the EVB).

1. Follow the board setup instructions in section 1.10 to provide the required connections with the EVK-R4.

2. Select “Control panel > Phones and Modem > Modems > Add”. This opens the Install New Modem Wizard.
3. Select the **Don't detect my modem** checkbox.

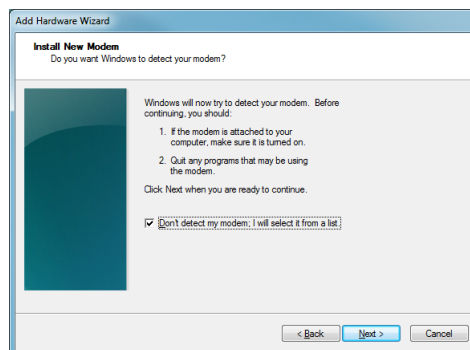

4. Select the **Standard Modem (33,600 bit/s)**.

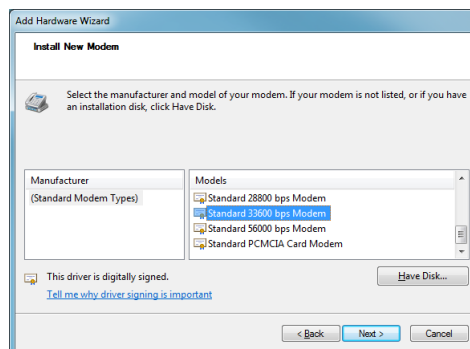

- Set the COM port on which the modem will be installed.

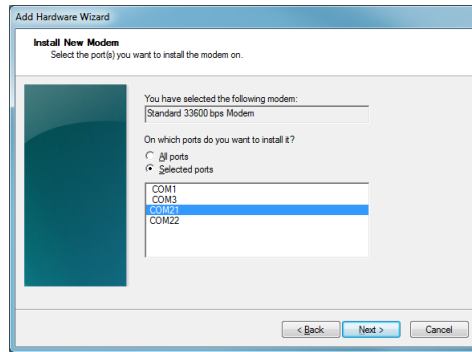

- From the “Device Manager”> Modems > Standard Modem 33,600 bps Modem #X (X is the assigned modem number) right click and select “Properties”.
- Select the “Advanced” tab.
- Add in the “Extra initialization commands” string: **AT&S0**
- Click on **OK**.

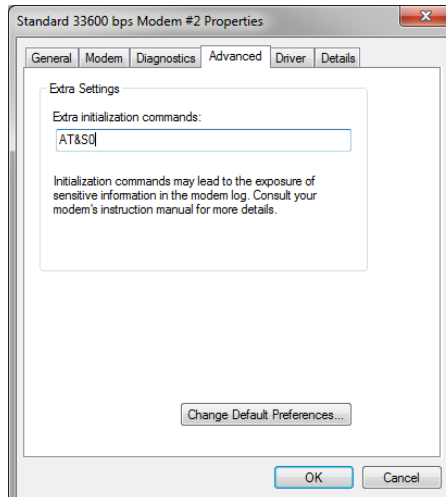

- Open the “Control Panel”.

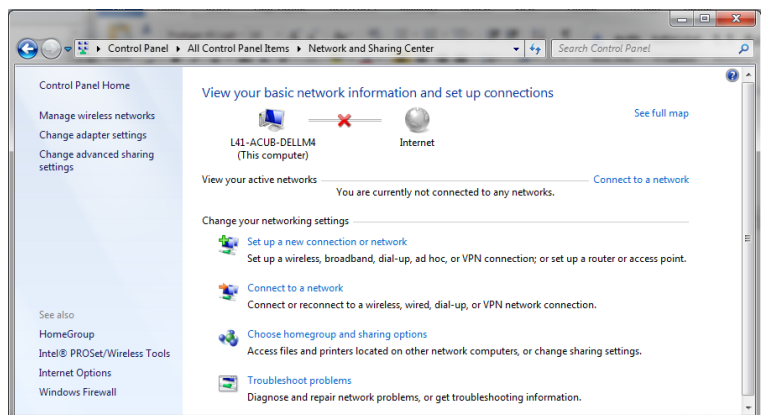

- Select “Set up a new connection or network”.

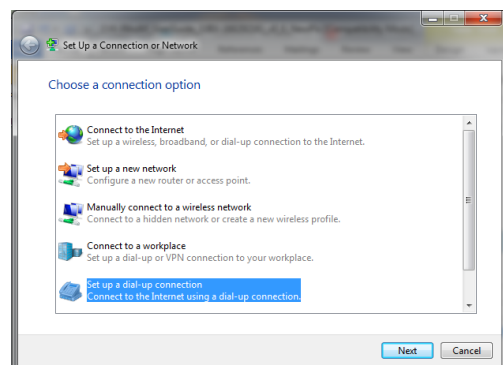

12. Select the modem, if requested (the question appears only if more than one modem is available).

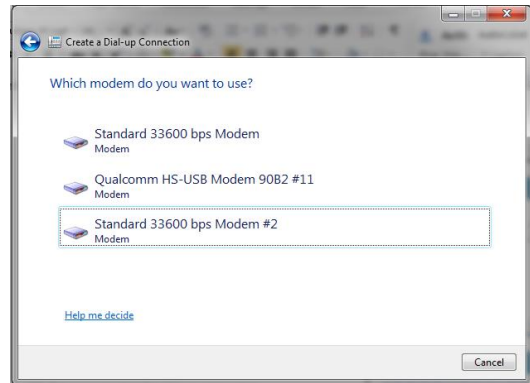

13. Enter parameters for dial-up connection:

- The module telephone number (\*99\*\*\*1#)
- The specific account information for the network operator (if needed)
- A name for the new connection

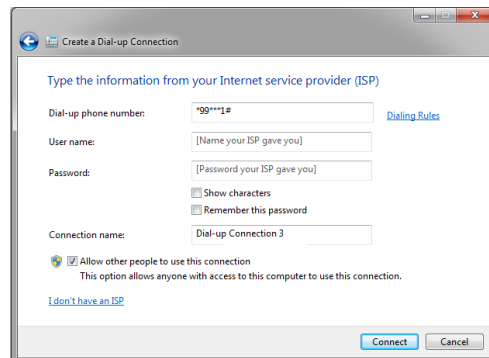

14. The packet data connection is now ready to be used with the EVK-R4. To check the connection, start a browser.



Consult the cellular network operator for the username and password. In most cases, these can be left empty.

The here below considerations are applicable only to **EVK-R422M8S**.

In detail the dial-up is working only in the following configurations:

- UART EVK with AT+USIO=0
- UART ADP with AT+USIO=1

## B.2 How to install and configure a modem data connection over USB

Section applicable to **EVK-R410M** and **EVK-R412M** only.

This example describes how to install and configure a data connection on a PC with the Windows 7 operating system using the TCP/IP stack of the PC, over the native USB interface of the SARA-R410M and SARA-R412M modules connected to the Windows PC by the **Cellular Native USB** connector (J105 on the ADP).

1. Follow the board setup instructions in section 1.10 to provide the required connections with the EVK-R4.

2. Select: “Control Panel > Network and Internet > Network and Sharing Center > Setup a new connection or network” This opens the “Choose a connection option” Wizard.

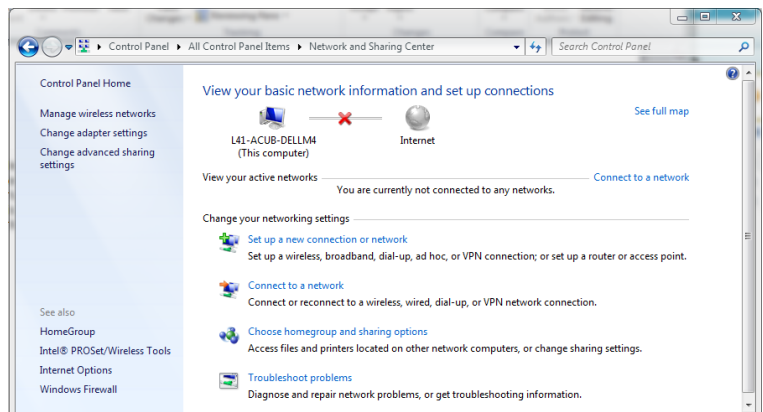

3. Select **Set up a dial-up connection**. Click on **Next**.

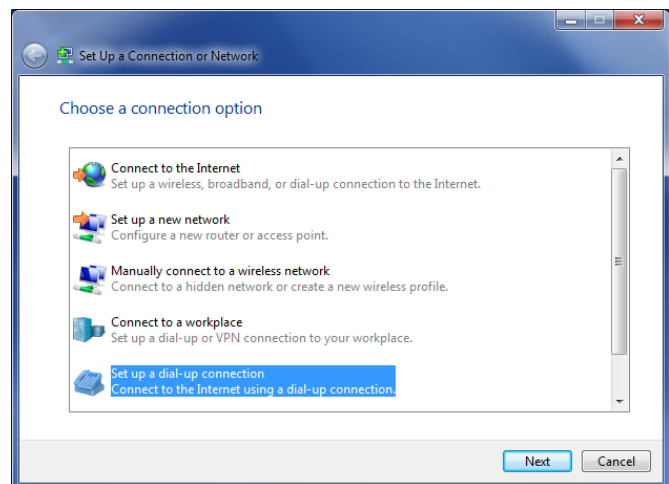

4. Select Qualcomm HS-USB Modem 90B2 #X (X=11 in the picture)

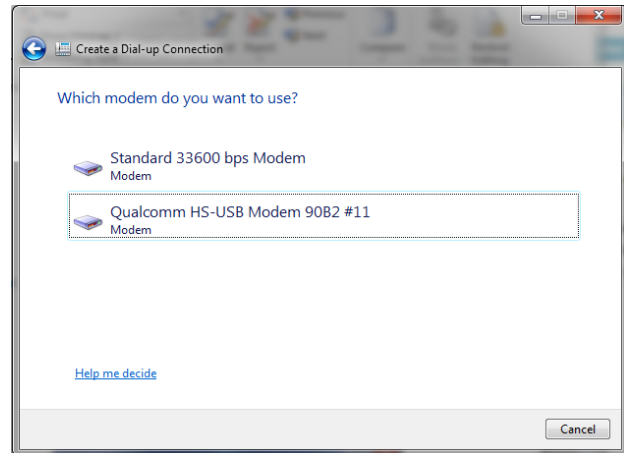

5. Enter the modem telephone number (\*99\*\*1#), select **Allow other people to use this connection**.

 Consult the cellular mobile network operator for the username and the password. In most cases, these can be left empty.

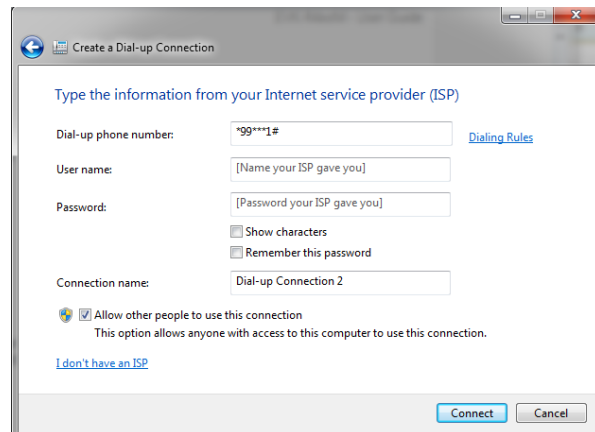

6. From the “**Device Manager**”, select the modem **Qualcomm HS-USB Modem 90B2** under use and right click to show the “**Properties**” window:  
Add **AT&S0** on the “**Extra Initialization Command**” line and click OK.  
Then click **Connect** to finalize the procedure.

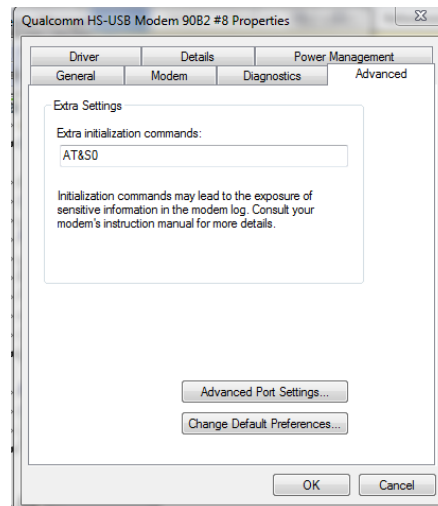

## C Examples of AT commands

For the complete description and syntax of the AT commands supported by SARA-R4 series cellular modules, see the u-blox SARA-R4 series AT commands manual [1].

For detailed examples of AT commands used for common operations, see the u-blox SARA-R41 series application development guide [4] and the u-blox SARA-R42 series application development guide [5].

### C.1 Data connection using external/internal TCP/IP stack

 There is no need to explicitly establish a PSD connection using SARA-R4 series modules. This device automatically establishes a PSD connection as part of the network registration and the attach procedure.

### C.2 Opening a TCP socket

Command sent by DTE (user)	DCE response (module)	Description
AT+CMEE=2	OK	Enables the cellular module to report verbose error result codes.
AT+CGATT?	+CGATT: 1 OK	Verifies the SARA-R4 module is attached to the network.
AT+CEREG?	+CEREG: 0,1 OK	Verify the network registration status.
AT+COFS=0	OK	Register the module on the network. The cellular module automatically registers itself on the cellular network. This command is necessary only if the automatic registration failed (AT+CEREG? returns 0,0).
AT+COPS?	+COPS: 0,0,"Verizon Wireless",7 OK	Read the operator name and radio access technology (RAT).
AT+USOCR=6	+USOCR: 0 OK	Create a TCP socket.
AT+USOCO=0,"195.34.89.241", 7	OK	Connect to the server.
	+UUSORD: 0,32	Greeting message.
AT+USORD=0,32	+USORD: 0,32,"u-blox AG TCP/UDP test service" OK	Retrieving the message.
AT+USOCL=0	OK	Closing the socket.



## C.3 Opening a UDP socket

Command sent by DTE (user)	DCE response (module)	Description
AT+CMEE=2	OK	Enables the cellular module to report verbose error result codes.
AT+CGATT?	+CGATT: 1 OK	Verifies the SARA-R4 module is attached to the network.
AT+CEREG?	+CEREG: 0,1 OK	Verify the network registration status.
AT+COPS=0	OK	Register the module on the network. The cellular module automatically registers itself on the cellular network. This command is necessary only if the automatic registration failed (AT+CEREG? returns 0,0).
AT+COPS?	+COPS: 0,0,"Verizon Wireless",7 OK	Read the operator name and radio access technology (RAT).
AT+USOCR=17	+USOCR: 0 OK	Create a UDP socket.
AT+USOST=0,"195.34.89.241", 7,13,"TestNumberOne"	+USOST: 0,13 OK	Connecting and storing text on the server.
	+UUSORF: 0,13	Echo server returning the message.
AT+USORF=0,13	+USORF: 0,"195.34.89.241" ,7,13,"TestNumberOne" OK	Reading the message from the server.
AT+USOCL=0	OK	Closing the socket.

## D Current consumption measurement

### D.1 EVK-R410M and EVK-R412M

The current consumption of the SARA-R410M and SARA-R412M modules can be measured on the EVK-R4 by removing the jumper socket from the **Cellular VCC supply jumper J404** available on the EVB-WL3 as illustrated in [Figure 9](#).

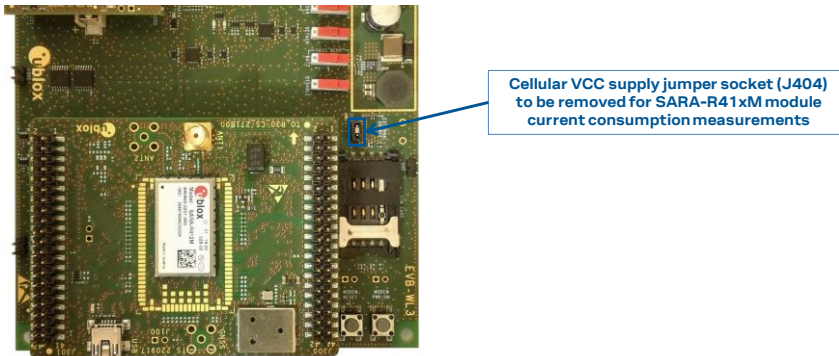

**Figure 9: Jumper socket to be removed for SARA-R410M / SARA-R412M modules current consumption measurement**

A suitable external digital multi-meter (as the Keysight 34465A, 34410A or 34411A) can be used for current consumption measurements. In this case, the 3.8 V supply circuit on the EVB will supply the SARA-R4 module, with the multi-meter placed in series as illustrated in [Figure 10](#).

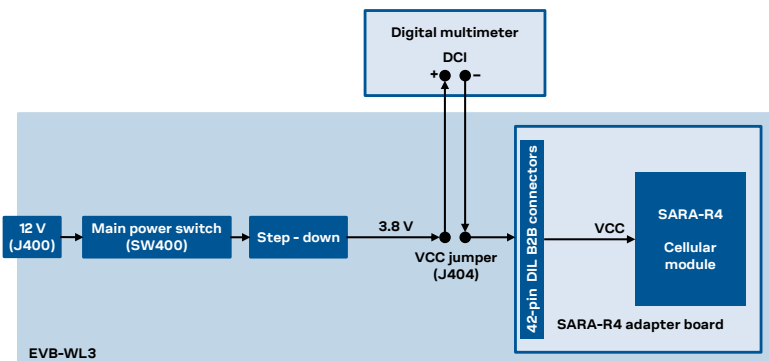

**Figure 10: Block diagram of current consumption setup for SARA-R410M / SARA-R412M modules using a multimeter**

Alternatively, a suitable external DC power supply with the dynamic current measurement capabilities (as for example, the portable and cheap Qoitech Otii Arc, or the more accurate Keysight N6705B, or the models designed for mobile communications Keysight 66319B/D or 66321B/D) can be used for current consumption measurements, acting also as the 3.8 V supply source for the SARA-R4 module mounted on the adapter board, as illustrated in [Figure 11](#).

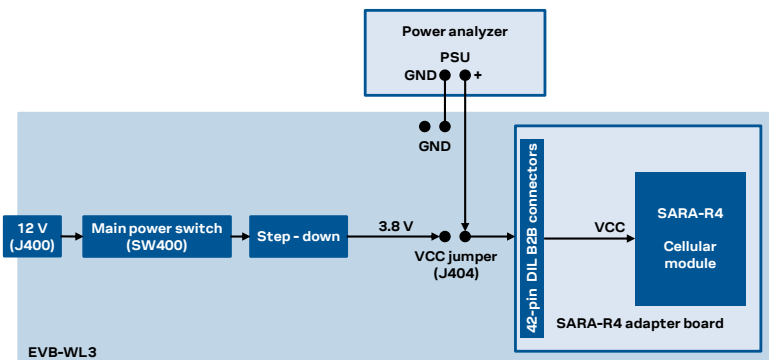

**Figure 11: Block diagram of current consumption setup for SARA-R410M / SARA-R412M modules using a DC power analyzer**

## D.2 EVK-R422M8S

The current consumption of the SARA-R422M8S modules can be measured on the EVK-R4 by removing the jumper socket from the **Cellular VCC supply jumper J109** available on the ADP-R4, as illustrated in [Figure 12](#).

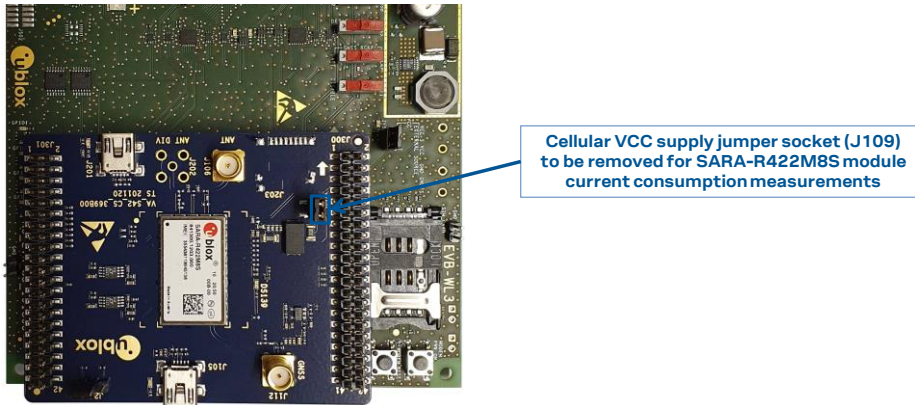

**Figure 12: Jumper socket to be removed for SARA-R422M8S modules current consumption measurement**

A suitable external digital multi-meter (as the Keysight 34465A, 34410A or 34411A) can be used for current consumption measurements. In this case, the 3.8 V supply circuit on the EVB will supply the SARA-R4 module, with the digital multi-meter placed in series, as illustrated in [Figure 13](#).

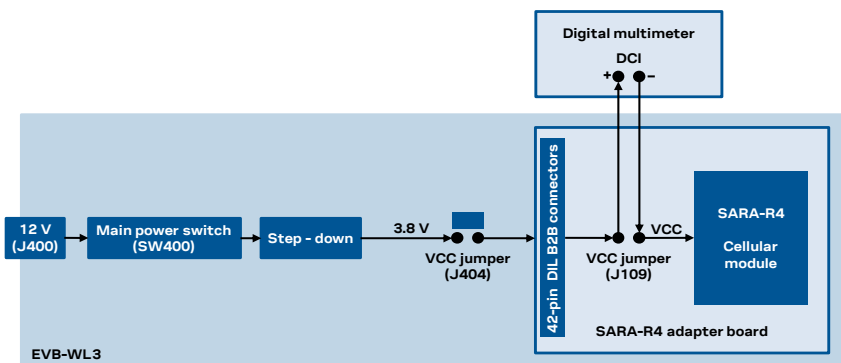

**Figure 13: Block diagram of current consumption setup for SARA-R422M8S modules**

Alternatively, a suitable external DC power supply with the dynamic current measurement capabilities (as for example, the portable and cheap Qoitech Otii Arc, or the more accurate Keysight N6705B, or the models designed for mobile communications Keysight 66319B/D or 66321B/D) can be used for current consumption measurements, acting also as the 3.8 V supply source for the SARA-R4 module mounted on the adapter board, as illustrated in [Figure 14](#).

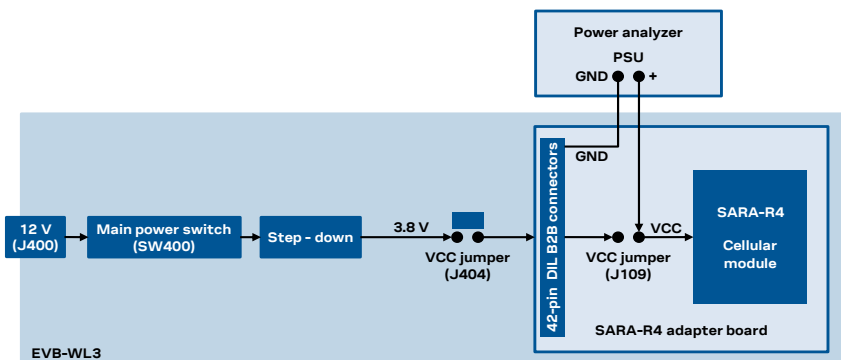

**Figure 14: Block diagram of current consumption setup for SARA-R422M8S using a DC power analyzer**

## E Glossary

Abbreviation	Definition
AC	Alternating current
ADP	Adapter Board
AT	AT Command Interpreter Software Subsystem, or attention
B2B	Board-To-Board
CTS	Clear To Send
DC	Direct Current
DCD	Data Carrier Detect
DCE	Data Communication Equipment
DCI	Direct Current
DDC	Display Data Channel interface
DIL	Dual In Line
DSR	DSC transponder response
DTE, TE	Data Terminal Equipment
DTR	Data Terminal Ready
EVB	Evaluation Board
GND	Ground
GNSS	Global Navigation Satellite System
GPIO	General Purpose Input Output
I <sup>2</sup> C	Inter-Integrated Circuit
IP	Internet Protocol
LED	Light Emitting Diode
LTE	Long Term Evolution
NB1	Narrowband IoT
PIN	Personal Identification Number
PSD	Packet-Switched Data
PSU	Power Supply Unit
RAT	Radio Access Technology
RF	Radio Frequency
RI	Ring Indicator
RTS	Request To Send
Rx	Receiver
SIM	Subscriber Identity Module
SMA	SubMiniature version A
TCP	Transfer Control Protocol
Tx	Transmitter
UART	Universal Asynchronous Receiver-Transmitter serial interface
UDP	User Datagram Protocol
USB	Universal Serial Bus

**Table 9: Explanation of the abbreviations and terms used**

## Declaration of conformities

The equipment is intended for indoor usage. It is the user's duty to verify if further restrictions apply, such as in airplanes, hospitals or hazardous locations (petrol stations, refineries...).

Any changes or modification made to this equipment will void its compliance to the safety requirements.

Maintenance, inspections and/or repairs of the EVK-R4 shall be performed by u-blox AG.

## Related documentation

- [1] u-blox SARA-R4 series AT commands manual, [UBX-17003787](#)
- [2] u-blox SARA-R4 series data sheet, [UBX-16024152](#)
- [3] u-blox SARA-R4 series system integration manual, [UBX-16029218](#)
- [4] u-blox SARA-R41 series application development guide, [UBX-18019856](#)
- [5] u-blox SARA-R42 series application development guide, [UBX-20050829](#)

All these documents are available on our website (<http://www.u-blox.com>).

 For regular updates to u-blox documentation and to receive product change notifications, register on our homepage ([www.u-blox.com](http://www.u-blox.com)).

## Revision history

Revision	Date	Name	Comments
R01	24-May-2017	sfal/sses/acub	Initial release
R02	19-Jul-2017	sses	Added EVK-R410M-02B and updated EVK-R404M-00B product status
R03	17-Aug-2017	sses	Updated EVK-R410M-01B product status
R04	04-Jan-2018	sses	Updated EVK-R410M-01B and EVK-R410M-02B product status
R05	23-Dec-2019	sses	Added EVK-R410M-52B, EVK-R410M-6, EVK-R410M-7, EVK-R412M-02B. Updated EVK-R404M-00B, EVK-R410M-01B, EVK-R410M-02B product status.
R06	23-Feb-2021	sses	Added EVK-R410M-8. Updated EVK-R410M-6, EVK-R410M-7, EVK-R410M-02B-00, EVK-R412M-02B-00 product status
R07	05-May-2021	sses	Added EVK-R422M8S
R08	08-Jul-2021	alos	Updated EVK-R422M8S-0 product status.