



# EVL6564H-100W

## 100 W transition-mode PFC pre-regulator demonstration board based on the L6564H

Data brief

### Features

- Line voltage range: 90 to 265 Vac
- Minimum line frequency ( $f_L$ ): 47 Hz
- Regulated output voltage: 400 V
- Rated output power: 100 W
- Maximum  $2f_L$  output voltage ripple: 20 V pk-pk
- Hold-up time: 10 ms ( $V_{DROD}$  after hold-up time: 300 V)
- Minimum switching frequency: 40 kHz
- Minimum estimated efficiency: 92% (@  $V_{in} = 90$  Vac,  $P_{OUT} = 100$  W)
- Maximum ambient temperature: 50 °C
- PCB type and size: single side, 35  $\mu$ m, CEM-1, 90 x 83 mm



**EVL6564H-100W**

isolated DC-DC converter that provides the output rails required by the load.

### Description

This demonstration board is based on the new transition-mode PFC controller L6564H and implements a 100 W, wide-range mains input, PFC pre-conditioner suitable for ballast, adapters, flat screen displays, and all SMPS having to meet IEC61000-3-2 or JEITA-MITI regulations.

The L6564H is a current-mode PFC controller operating in transition mode (TM) which embeds the same features existing in the L6564 with the addition of a high voltage startup source. These functions make the IC especially suitable for applications that must be compliant with energy saving regulations and where the PFC pre-regulator works as the master stage.

The EVAL6564H-100W implements a power factor correction (PFC) pre-regulator 100 W, continuous power, on a regulated 400 V rail from a wide-range mains voltage and providing for the reduction of the mains harmonics, allowing the European EN61000-3-2 or the Japanese JEITA-MITI standard to be met. The regulated output voltage is typically the input for the cascaded

# 1 Electrical schematic

Figure 1. Electrical schematic

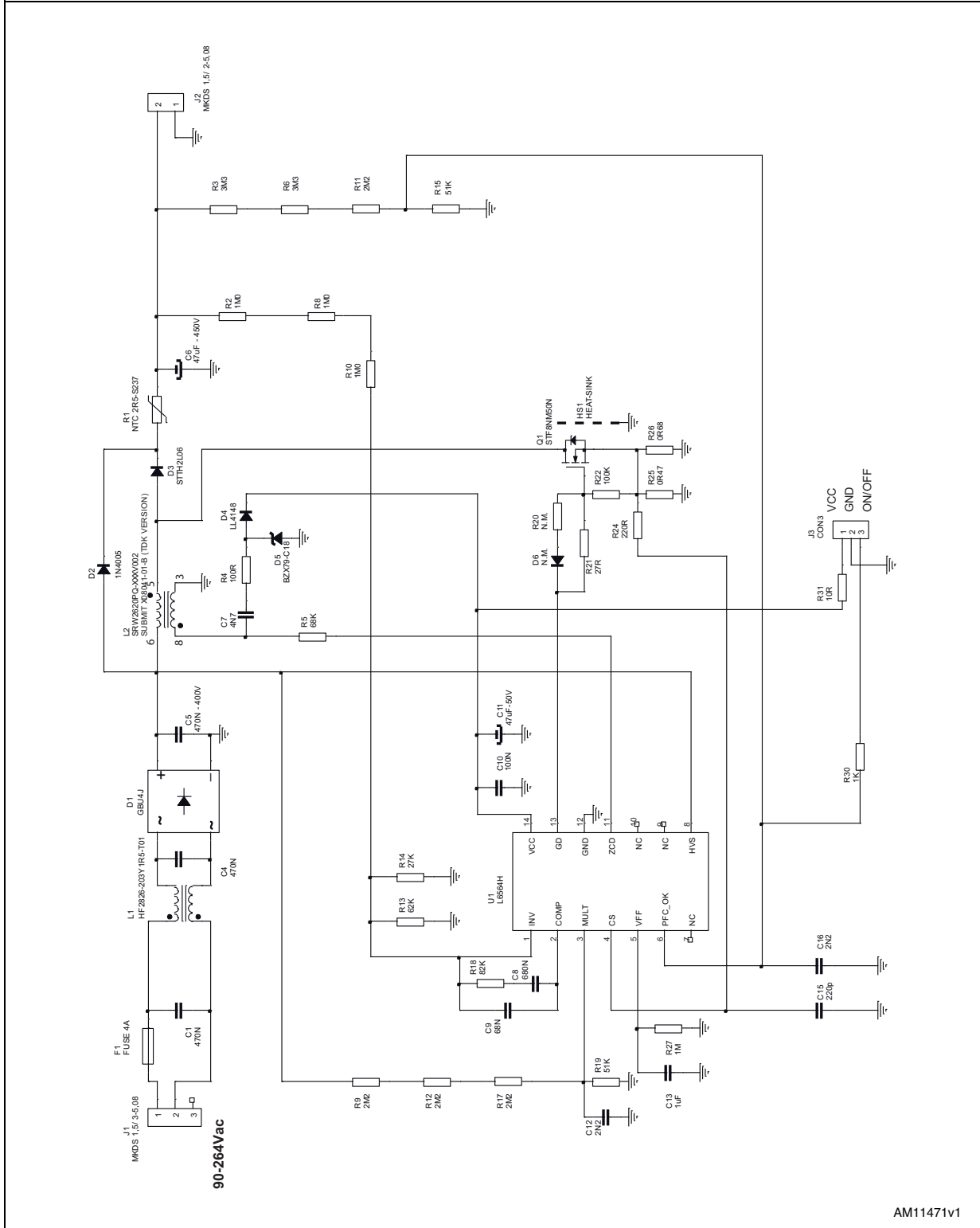

## 2 Revision history

Table 1. Document revision history

Date	Revision	Changes
16-Apr-2012	1	Initial release.