

## High power inverse buck for dimmable LED application with MASTERGAN4, HVLED002 and VIPER06XS

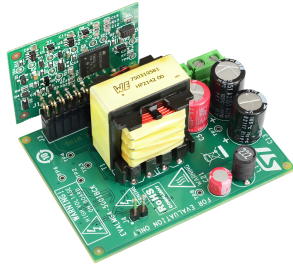

### Features

- Input voltage:  $V_{in} = 400 \text{ Vdc}$ ,  $V_{dim} = 10 \text{ Vdc}$
- Output voltage range: 150 V – 350 V
- Output current: 0.7 A – 1 A – 1.3 A, selectable with shunt resistor
- High precision output current, with output current variation lower than 5%
- High efficiency up to 99.4% @  $I_{out} = 1 \text{ A}$   $V_{out} = 350 \text{ V}$
- No heatsink required
- Dimming between 0% - 100%
- PCB dimension: 48.7 mm x 65.1 mm x 37 mm
  - Motherboard: 48.7 mm x 65.1 mm
  - Daughterboard: 30 mm x 40 mm
- RoHS compliant

### Description

This document describes the [EVLMG4-500WIBCK](#) evaluation board, designed to drive a dimmable LED load with a GaN-based, synchronously rectified inverse buck topology; the switching element and diode are replaced by MASTERGAN4, mounted on a daughterboard to obtain a compact and scalable application. The HVLED002 controller manages the inverse buck mainly composed by T1 and MASTERGAN4.

The supply of the HVLED002 is generated by ViPer06XS, that converts the input voltage of the buck to the voltage needed at Vdd pin, eliminating the need of an external power supply.

The circuit is configured to generate 1 A, but different output currents are selectable changing the shunt resistor combination on the daughterboard with the MASTERGAN4.

The board operates with 400 V input voltage and output voltage range between 150 V and 350 V.

A dimming circuit is present on the board. It consists of two circuits: the analog and PWM circuit. It enables the regulation of the output current between the 100% and 0%.

The over voltage and short circuit protection are guaranteed.

Product status link

[EVLMG4-500WIBCK](#)

# 1 Architecture and component placements

Figure 1. EVLMG4-500WIBCK motherboard – top component placement

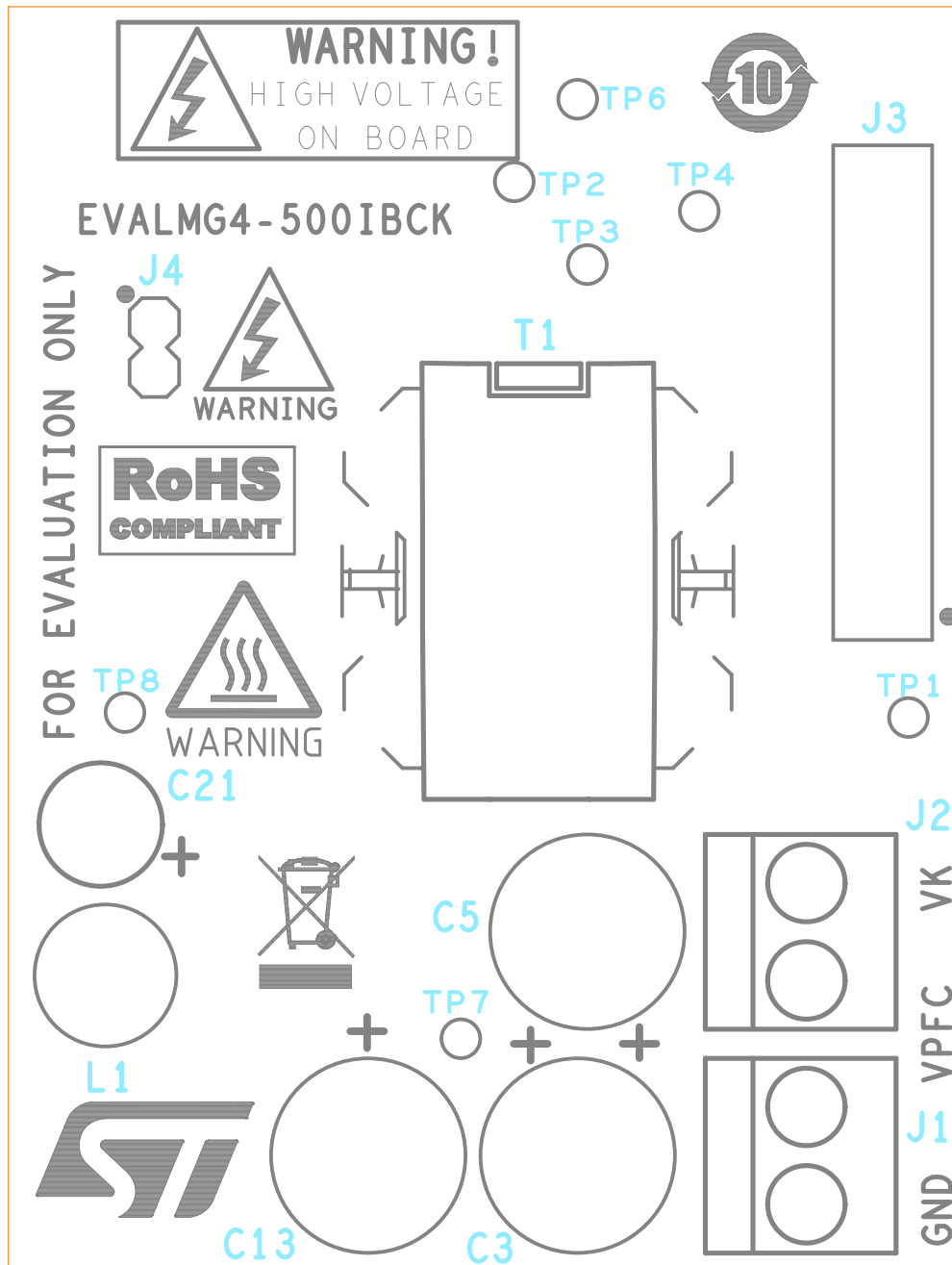

**Figure 2. EVLMG4-500WIBCK motherboard – bottom component placement**

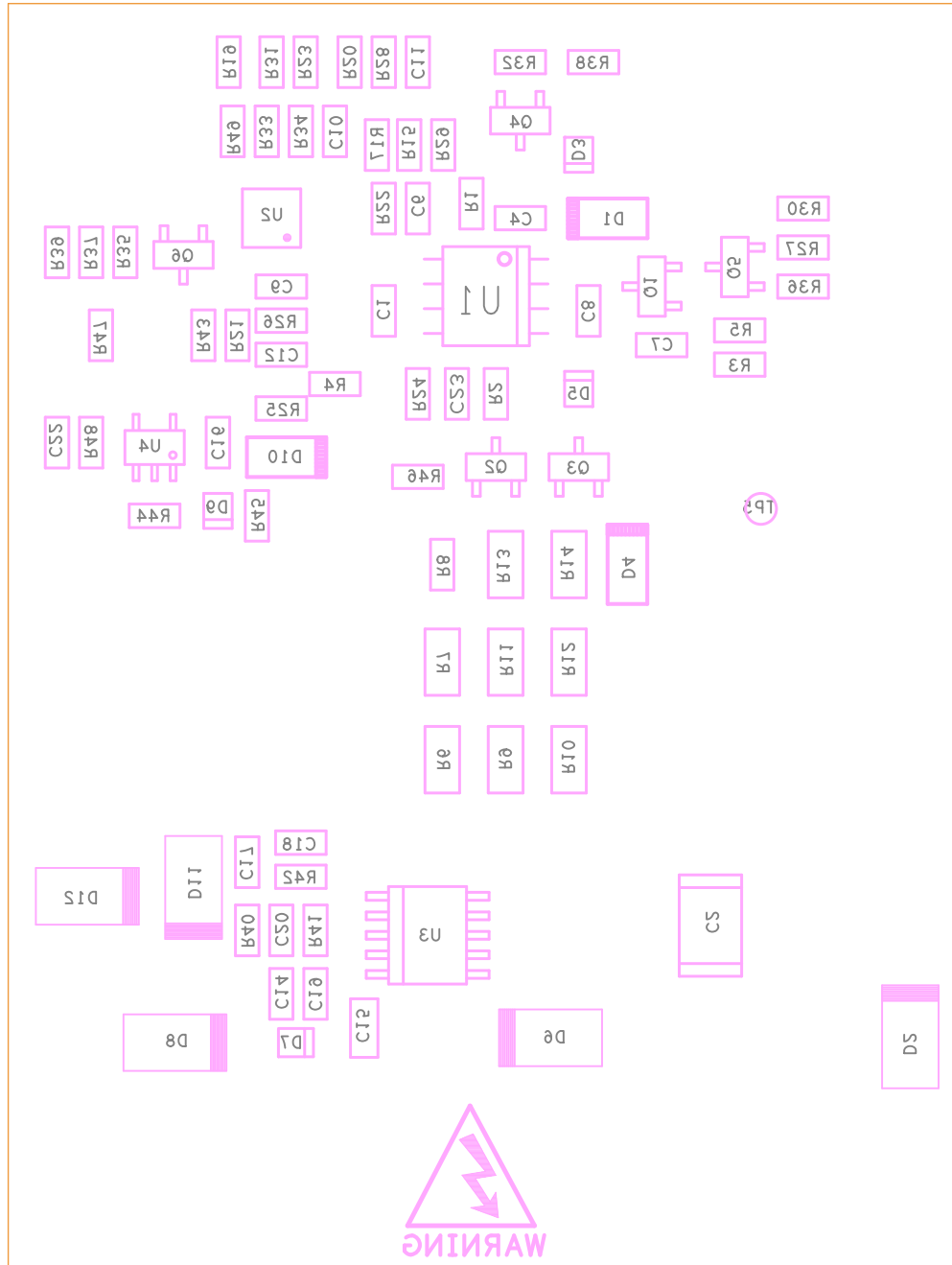

**Figure 3. EVLMG4-500WIBCK daughterboard – top component placement**

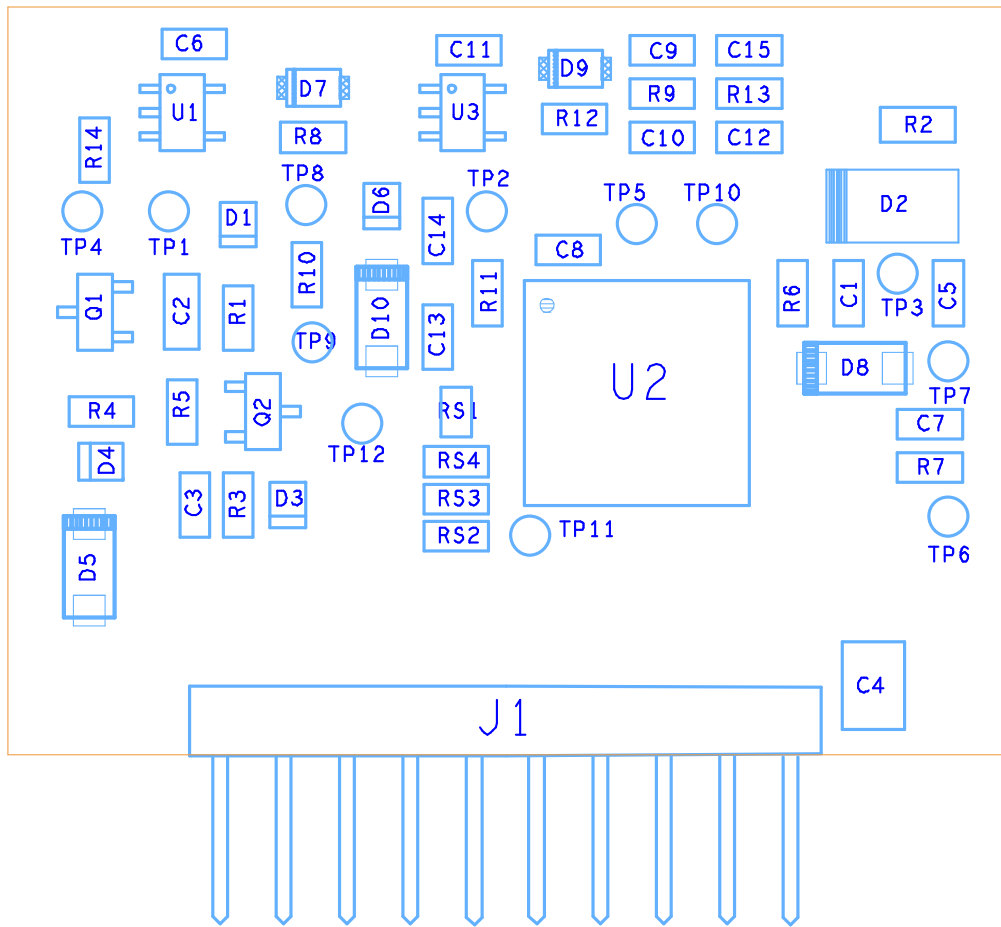

## 2 Board input connection

The following image shows how to supply the EVLMSG4-500WIBCK (and the connection between mother and daughter board).

**Figure 4. EVLMSG4-500WIBCK – Supply (and connection between mother and daughterboard)**

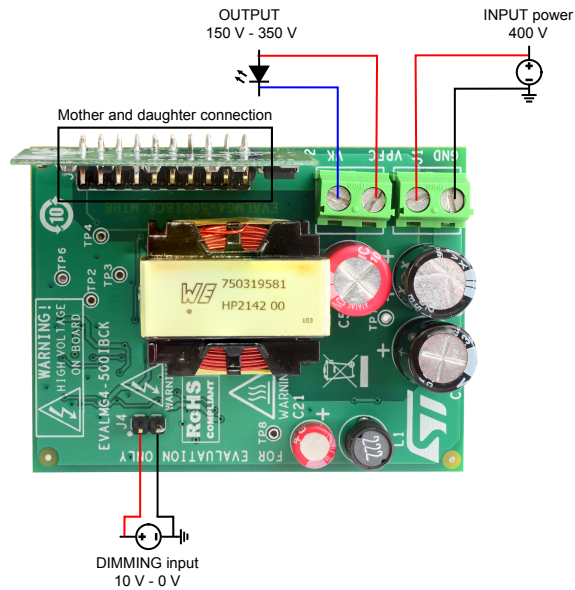

**Table 1. Connector Map**

Ref	Pin #	Name	Function	Description
J1	1	Vcc	INPUT power	Board supply voltage: set the value at 400 V
	2	GND		Board reference potential
J2	1,2	OUT	OUTPUT	Board output connection (i.e. LED)
J4	1	Vdim	Dimming input	Dimming supply voltage
	2	GND		Signal ground

**Table 2. Mother – daughter connection**

Ref	Pin #	Name	Function	Description
J3	1,2	Vcc	INPUT power	MasterGaN4 power supply: set the value at 400 V
	3,4,7,8	N.C.	Not connected	
	5,6	OUT	Half-bridge output	Drain voltage, connected to the inductor
	9,10,11, 13,14,15, 17,19	GND	GND	Signal ground
	12	SENSE	SENSE	Sense pin, determines the duration of the on-time. Connected with the controller.
	18	Vc	Secondary input power	Logic supply voltage. It is fixed by ViPer06XS at 14 V.

Ref	Pin #	Name	Function	Description
J3	16	GD	Gate driver	Ouput signal from the controller. This signal, through the logic gates embedded on the daughterboard, is split into two complementary signals and drives the MASTERGAN4.
	20	PWM_C	PWM_C	Enable PWM dimming circuit and disable the MASTERGAN4 during the protection

### 3 Schematic diagram

Figure 5. EVLMG4-500WIBCK motherboard schematic

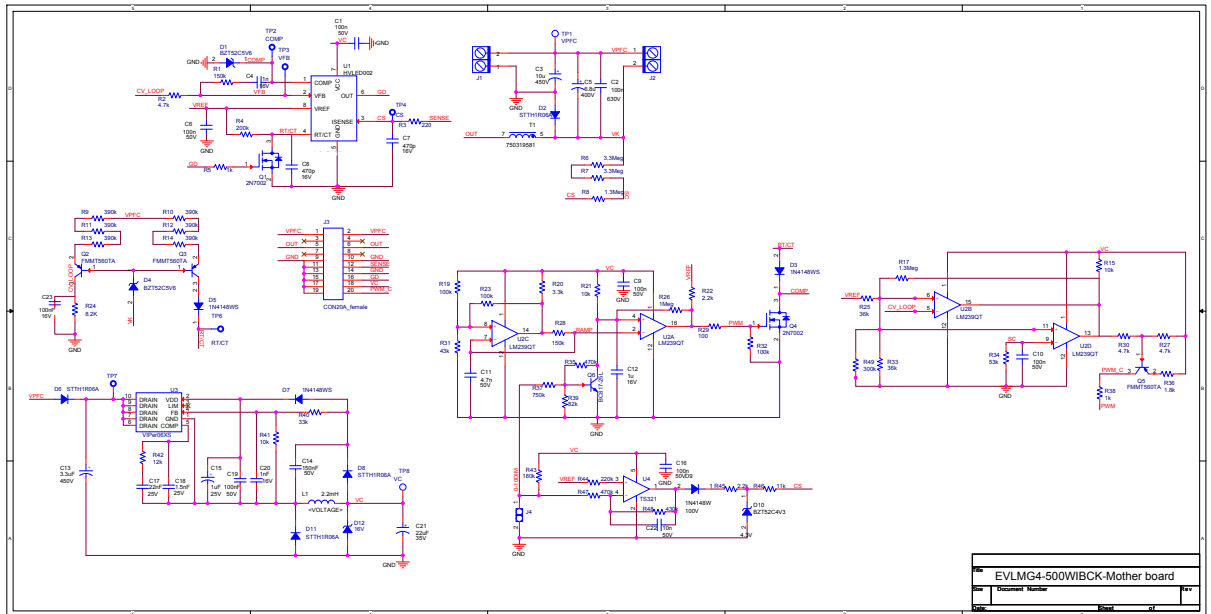

**Figure 6. EVLMG4-500WIBCK daughterboard schematic**

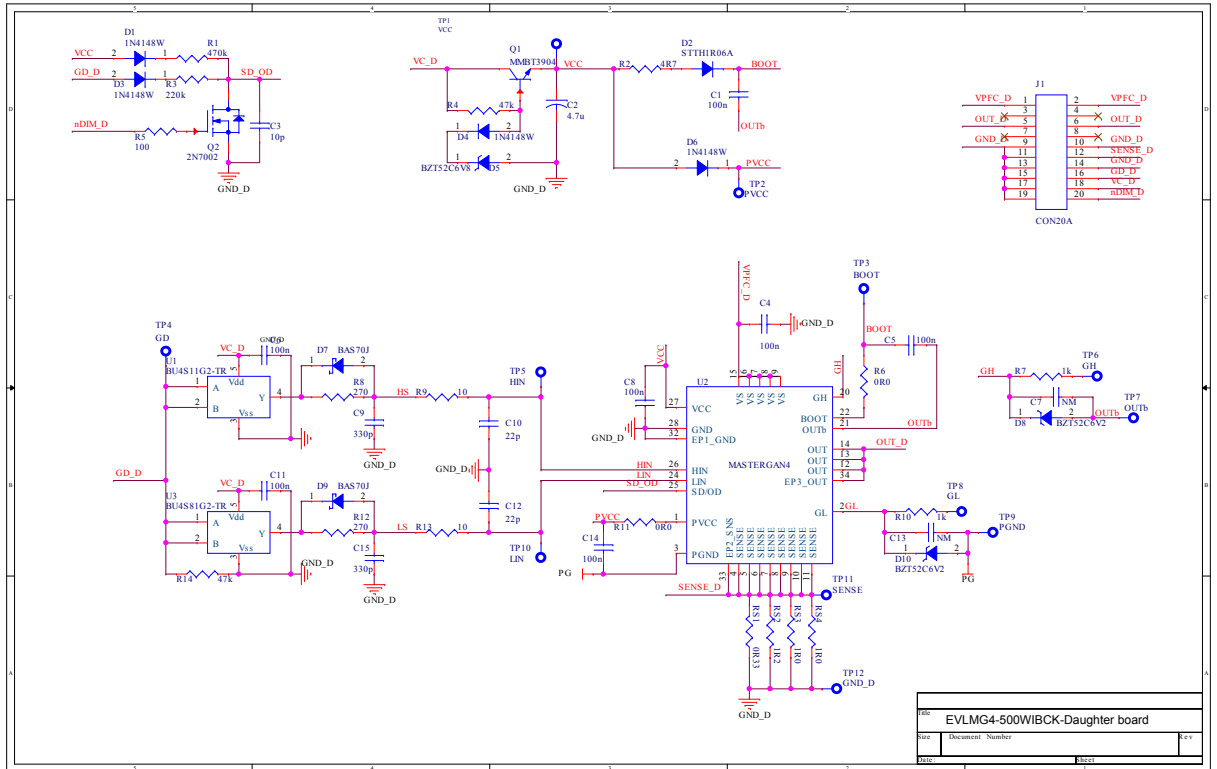



## 4 Bill of materials

**Table 3. Bill of material of motherboard**

Reference	Value	Manufacturer	Part Number
C1	100n	WURTH ELEKTRONIK	885012206095
C6	100n	WURTH ELEKTRONIK	885012206095
C9	100n	WURTH ELEKTRONIK	885012206095
C10	100n	WURTH ELEKTRONIK	885012206095
C16	100n	WURTH ELEKTRONIK	885012206095
C2	100n	WURTH ELEKTRONIK	885342211006
C3	10u		
C4	1n	WURTH ELEKTRONIK	885012206034
C5	6.8u	WURTH ELEKTRONIK	860021375010
C7	470p	WURTH ELEKTRONIK	885012006027
C8	470p	WURTH ELEKTRONIK	885012006027
C11	4.7n	WURTH ELEKTRONIK	885012206087
C12	1u	WURTH ELEKTRONIK	885012206052
C13	3.3uF		
C14	150nF		
C15	1uF	WURTH ELEKTRONIK	885012207078
C17	22nF	WURTH ELEKTRONIK	885012206067
C18	1.5nF	WURTH ELEKTRONIK	885012206060
C19	100nF	WURTH ELEKTRONIK	885012206095
C20	1nF	WURTH ELEKTRONIK	885012206034
C21	22uF	WURTH ELEKTRONIK	870235673001
C22	10n	WURTH ELEKTRONIK	885012206089
C23	100nF		
D1	BZT52C5V6	Diodes Incorporated	
D4	BZT52C5V6	Diodes Incorporated	
D2	STTH1R06A	STMicroelectronics	STTH1R06A
D6	STTH1R06A	STMicroelectronics	STTH1R06A
D8	STTH1R06A	STMicroelectronics	STTH1R06A
D11	STTH1R06A	STMicroelectronics	STTH1R06A
D3	1N4148WS	VISHAY	
D5	1N4148WS	VISHAY	
D7	1N4148WS	VISHAY	
D9	1N4148W	VISHAY	
D10	BZT52C4V3	Diodes Incorporated	
D12	16V	VISHAY	SML4745-E3/61
J1	MORSV-508-2P_screw	WURTH ELEKTRONIK	691213510002
J2	MORSV-508-2P_screw	WURTH ELEKTRONIK	691213510002

Reference	Value	Manufacturer	Part Number
J3	CON20A_female		
J4	STRIP 1x2	WURTH ELEKTRONIK	61300211121
L1	2.2mH	ITACOIL	SLD0608222
PCB1	InvBuckMG_MB_PCB		
Q1	2N7002	Infineon	2N7002H6327XTSA2 or BSS1287NX138, BSN20B, DMN61D
Q4	2N7002	Infineon	2N7002H6327XTSA2 or BSS1287NX138, BSN20B, DMN61D
Q2	FMMT560TA	Diodes Incorporated	STR2550
Q3	FMMT560TA	Diodes Incorporated	STR2550
Q5	FMMT560TA	Diodes Incorporated	STR2550
Q6	BC817-25L	Onsemi	BC817-25LT1G or MMBT3904 / PMBS3904, BC847A, BC848C
R1	150k		
R28	150k		
R2	4.7k		
R27	4.7k		
R30	4.7k		
R3	220		
R4	200k		
R5	1k		
R38	1k		
R6	3.3Meg		
R7	3.3Meg		
R8	1.3Meg		
R9	390k		
R10	390k		
R11	390k		
R12	390k		
R13	390k		
R14	390k		
R15	10k		
R21	10k		
R41	10k		
R17	1.3Meg		
R19	100k		
R23	100k		
R32	100k		
R20	3.3k		
R22	2.2k		
R45	2.2k		
R24	8.2K		
R25	36k		
R33	36k		

Reference	Value	Manufacturer	Part Number
R26	1Meg		
R29	100		
R31	43k		
R34	53k		
R35	470k		
R47	470k		
R36	1.8k		
R37	750k		
R39	82k		
R40	33k		
R42	12k		
R43	180k		
R44	220k		
R46	11k		
R48	430k		
R49	300k		
TP1	VPFC		
TP2	COMP		
TP3	VFB		
TP4	CS		
TP5	PHASE		
TP6	RT/CT		
TP7	TP		
TP8	VC		
T1	750319581	WURTH ELEKTRONIK	750319581
U1	HVLED002	STMicroelectronics	HVLED002
U2	LM239QT	STMicroelectronics	LM239QT
U3	VIPer06XS	STMicroelectronics	VIPER06XS
U4	TS321	STMicroelectronics	TS321ILT

**Table 4. Bill of material of daughterboard**

Reference	Value	Manufacturer	Part Number
C1	100n	WURTH ELEKTRONIK	885012206095
C5	100n	WURTH ELEKTRONIK	885012206095
C6	100n	WURTH ELEKTRONIK	885012206095
C8	100n	WURTH ELEKTRONIK	885012206095
C11	100n	WURTH ELEKTRONIK	885012206095
C14	100n	WURTH ELEKTRONIK	885012206095
C2	4.7u	WURTH ELEKTRONIK	885012107018
C3	10p	WURTH ELEKTRONIK	885012006051

Reference	Value	Manufacturer	Part Number
C4	100n		
C7	NM		
C13	NM		
C9	330p	WURTH ELEKTRONIK	885012006026
C15	330p	WURTH ELEKTRONIK	885012006026
C10	22p	WURTH ELEKTRONIK	885012006053
C12	22p	WURTH ELEKTRONIK	885012006053
D1	1N4148W	VISHAY	1N4148WS-E3-08 / -E3-18 or equivalent
D3	1N4148W	VISHAY	1N4148WS-E3-08 / -E3-18 or equivalent
D2	STTH1R06A	STMicroelectronics	STTH1R06A or equivalent
D4	1N4148W	VISHAY	1N4148WS-E3-08 / -E3-18 or equivalent
D5	BZT52C6V8		BZT52C6V8
D6	1N4148W	VISHAY	1N4148WS-E3-08 / -E3-18 or equivalent
D7	BAS70J	STMicroelectronics	BAS70JFILM or equivalent
D9	BAS70J	STMicroelectronics	BAS70JFILM or equivalent
D8	BZT52C6V2		BZT52C6V2
D10	BZT52C6V2		BZT52C6V2
J1	CON20A		
PCB1	InvBuckMG_DB1_PCB		
Q1	MMBT3904	STMicroelectronics	MMBT3904
Q2	2N7002	Infineon	2N7002H6327XTSA2 or BSS1287NX138, BSN20B, DMN61D
RS1	0R33		LTR10EVHFLR330
RS2	1R2		
RS3	1R0		
RS4	N.M.		
R1	470k		
R2	4R7		
R3	220k		
R4	47k		
R14	47k		
R5	100		
R6	0R0		
R11	0R0		
R7	1k		
R10	1k		
R8	270		
R12	270		
R9	10		
R13	10		
TP1	VCC		
TP2	PVCC		

Reference	Value	Manufacturer	Part Number
TP3	BOOT		
TP4	GD		
TP5	HIN		
TP6	GH		
TP7	OUTb		
TP8	GL		
TP9	PGND		
TP10	LIN		
TP11	SENSE		
TP12	GND_D		
U1	BU4S11G2-TR	Rohm Semiconductor	BU4S11G2-TR
U2	MASTERGAN4	STMicroelectronics	MASTERGAN4
U3	BU4S81G2-TR	Rohm Semiconductor	BU4S81G2-TR

## Revision history

**Table 5. Document revision history**

Date	Version	Changes
07-Jun-2022	1	Initial release.

## Contents

<b>1</b>	<b>Architecture and component placements .....</b>	<b>2</b>
<b>2</b>	<b>Board input connection .....</b>	<b>5</b>
<b>3</b>	<b>Schematic diagram .....</b>	<b>7</b>
<b>4</b>	<b>Bill of materials .....</b>	<b>9</b>
	<b>Revision history .....</b>	<b>14</b>
	<b>Contents .....</b>	<b>15</b>
	<b>List of tables .....</b>	<b>16</b>
	<b>List of figures .....</b>	<b>17</b>

## List of tables

<b>Table 1.</b>	Connector Map . . . . .	5
<b>Table 2.</b>	Mother – daughter connection . . . . .	5
<b>Table 3.</b>	Bill of material of motherboard . . . . .	9
<b>Table 4.</b>	Bill of material of daughterboard . . . . .	11
<b>Table 5.</b>	Document revision history . . . . .	14



## List of figures

<b>Figure 1.</b>	EVLMG4-500WIBCK motherboard – top component placement . . . . .	2
<b>Figure 2.</b>	EVLMG4-500WIBCK motherboard – bottom component placement. . . . .	3
<b>Figure 3.</b>	EVLMG4-500WIBCK daughterboard – top component placement . . . . .	4
<b>Figure 4.</b>	EVLMG4-500WIBCK – Supply (and connection between mother and daughterboard) . . . . .	5
<b>Figure 5.</b>	EVLMG4-500WIBCK motherboard schematic. . . . .	7
<b>Figure 6.</b>	EVLMG4-500WIBCK daughterboard schematic . . . . .	8