

SRK1000B adaptive synchronous rectification controller for flyback converter demonstration board with logic level SR MOSFET

Data brief

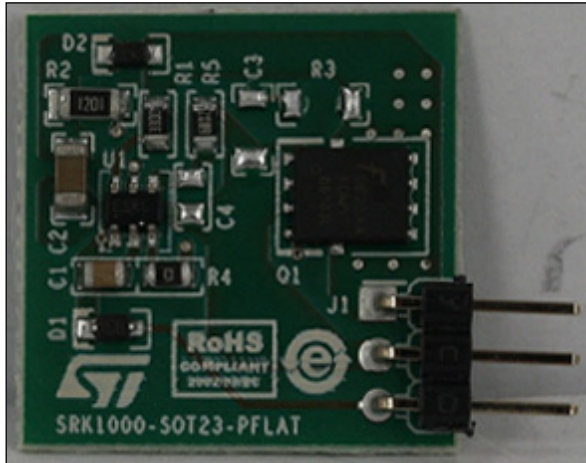

Features

- Synchronous rectifier for flyback converter, with fixed turn-on and adaptive turn-off
- V_{CC} range: 3.5 V to 32 V
- DVS max. operating voltage 90 V
- Max. frequency: 500 kHz
- Internal gate drive for N-channel MOSFET
- SR MOSFET type: FDMS86103L logic level (100 V - 12 m Ω) PowerFLAT 5 x 6 package

Description

The EVLSRK1000B-PF is a demonstration board, designed for evaluation of the SRK1000B synchronous rectification controller.

The SRK1000B implements a control scheme specific for secondary-side synchronous rectification in flyback converters and provides high-current gate-drive outputs for driving N-channel power MOSFET.

The device can operate both in quasi-resonant applications and in fixed frequency (FF) mixed DCM-CCM applications. The board is provided with a setting suitable for QR applications. To use in FF applications, a 100 pF capacitor needs to be added in C4. A 68 k Ω resistor (R5) is provided on the TON pin that fixes the blanking after the turn-on to about 0.8 μ s.

The board includes the SR MOSFET (PowerFLAT 5 x 6 package) and can be easily implemented into an existing converter to substitute rectifier diodes.

Electrical schematic

Figure 1. EVLSRK1000B-PF electrical schematic

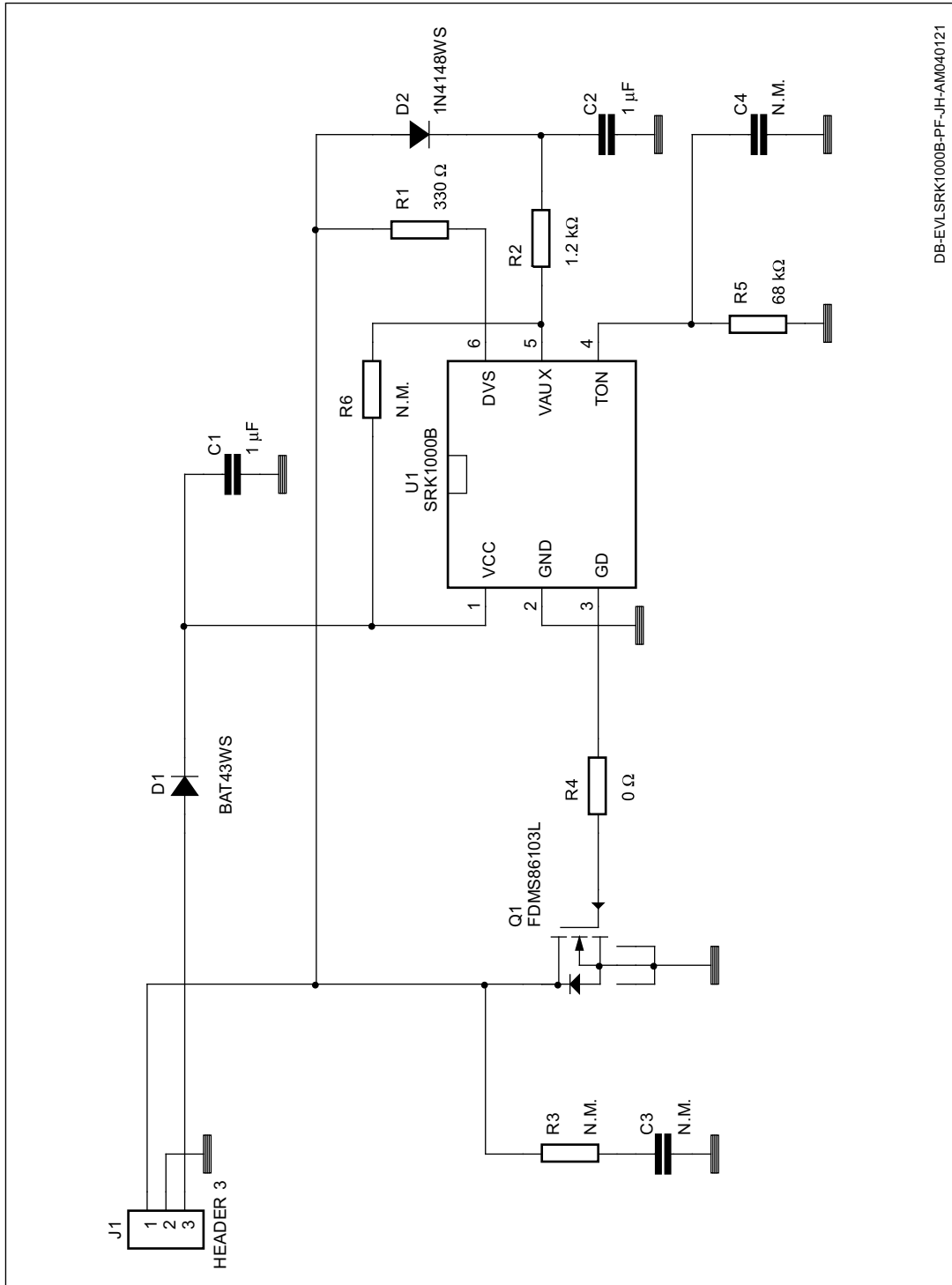

DB-EVLSRK1000B-PF-JH-AM040121

Revision history

Table 1. Document revision history

Date	Revision	Changes
19-Oct-2018	1	Initial release.