

45W USB Type-C[®] Power Delivery 3.0 adapter based on STCH03, SRK1001 and STUSB4761

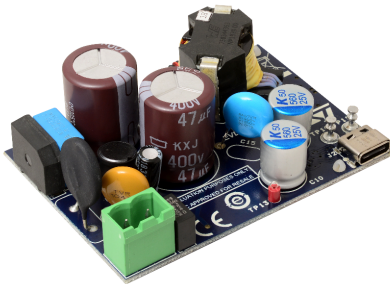

Product status link

[EVLSTCH03-45WPD](#)

Features

- USB-IF certified
- USB Type-C[®] PD 3.0 references:
 - Power Brick EVLSTCH03-45WPD TID: 2071
 - PD Controller STUSB4761 TID: 2070
- Universal AC input range V_{IN} :
 - 90 V_{AC} to 264 V_{AC}
- PD output profile:
 - 5 V - 9 V - 12 V - 15 V @ 3 A
 - 20 V @ 2.25 A
- Maximum efficiency at full load:
 - > 90% @ AC input range
- No-load consumption (no cable plug-in):
 - < 30 mW @ 230 V_{AC}
- Energy efficiency meeting all DOE and UE CoC requirements
- Isolated quasi-resonant flyback topology with adaptive synchronous rectification
- Programmable output voltage and current protections
- Safety according to EN60065
- EMI according to EN55022 - Class B
- Compact form factor: 70 x 50 X 26.8 mm
- RoHS compliant

Description

The **EVLSTCH03-45WPD** 45W USB Type-C[®] Power Delivery 3.0 adapter is a USB-IF certified solution and reference design. The **EVLSTCH03-45WPD** is an isolated power supply with a standalone USB PD controller. The evaluation board implements at the primary side a quasi-resonant flyback converter based on the **STCH03** controller with optocoupler feedback for voltage regulation. This controller combines a high performance low-voltage PWM controller chip with a 650 V HV start-up cell in the same package. The STCH03 controller drives the gate of the new 650 V MDmesh™ M6 technology Power MOSFET **STD7N65M6**.

At the secondary side, to increase the system efficiency, the rectification is based on the **SRK1001** adaptive synchronous rectification controller. This controller drives the gate of the 100V STripFET™ F7 technology Power MOSFET **STL110N10F7**.

Always on the secondary side the CC/CV regulation loop to drive the power regulation stage and the USB Type-C[®] PD interface are based on the **STUSB4761** controller. This controller offers the benefits of a full hardware USB PD stack allowing robust, deterministic and safe negotiation in line with USB PD standard.

The EVLSTCH03-45WPD is protected against destructive electrostatic discharge from the USB Type-C[®] connector using a Dual Transil array for ESD protection **ESDA25L**.

The evaluation board implements a robust adapter protected for output overvoltage, output undervoltage, output overpower and output short-circuit. This reference design, based on STMicroelectronics semiconductors, helps designers to develop adapters with a short bill of materials in order to obtain a cost-effective and fast design.

1 Electrical schematic

Figure 1. EVLSTCH03-45W evaluation board schematic

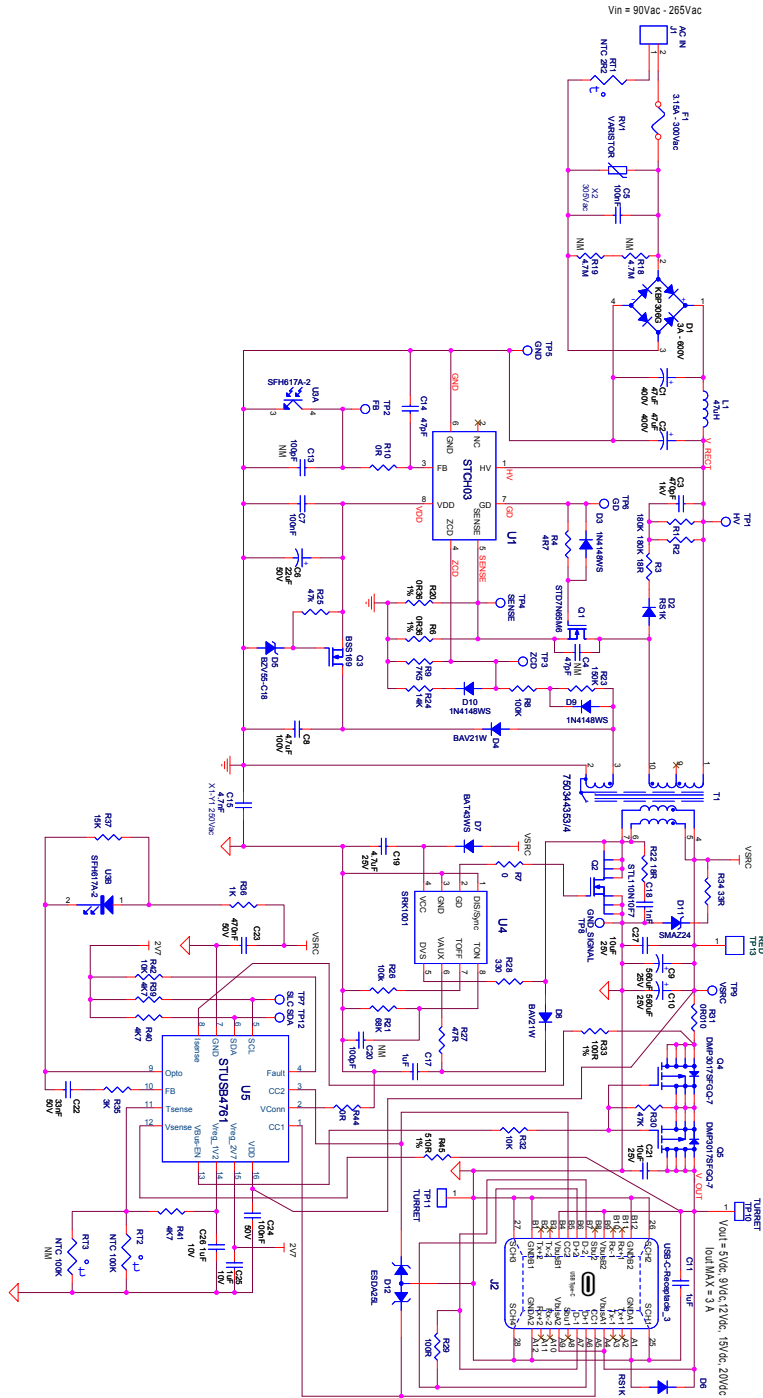

Revision history

Table 1. Document revision history

Date	Version	Changes
21-Oct-2019	1	Initial release.
9-Dec-2019	2	Compact form factor value updated in Section Features

Contents

1	Electrical schematic	3
	Revision history	4
	Contents	5