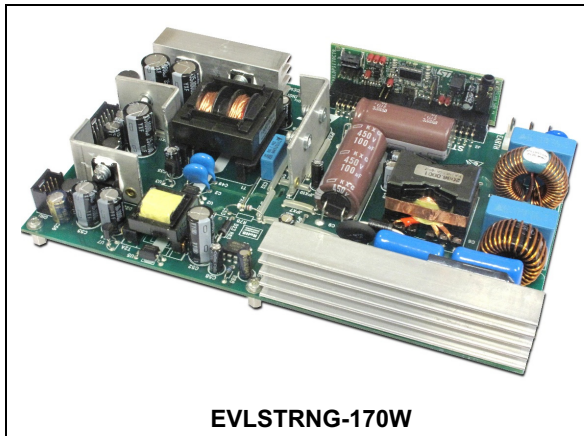

---

**170 W SMPS with digitally controlled PFC and resonant LLC stage  
based on the STNRG388A**

---

Data brief

**EVLSTRNG-170W****Features**

- Digital controller: STNRG388A
- Enhanced constant ON Time PFC
- Timeshift controlled LLC
- Max. power: 170 W
- Efficiency: more than 91% at full load
- Standby consumption: <150 mW with 50 mW secondary side load
- Input voltage range: from 90 to 264 Vdc
- Multiple output rails: 24 V (6 A), 12 V (2 A), 5 V (2 A)
- Modular power and control board

**Description**

The EVLSTNRG-170W evaluation board is intended for evaluating the STNRG388A digital controller in off-line power conversion applications such as digital industrial power supplies.

The solution implements a PFC stage followed by a resonant LLC stage supporting up to 170 W. The application supports multiple output rails: a high power 24 V (6 A) channel for the main application, 1 auxiliary 12 V (2 A) for the controller and an always-on 5 V (2 A) standby.

The STNRG388A power conversion dedicated peripherals (SMEDs) offer the flexibility to drive the PFC in transition mode (DCM-CCM boundary) while the resonant LLC is controlled with timeshift control (TSC). In parallel to managing the two conversion stages, STNRG388A guarantees all the protections required by the application as well as implementing the advanced Anti Capacitive protection.

Thanks to the digital core of STNRG388A, it is also possible to monitor, control and debug the EVLSTNRG-170W board via a convenient HyperTerminal control.

# 1 Schematic diagrams

Figure 1. Electrical main board

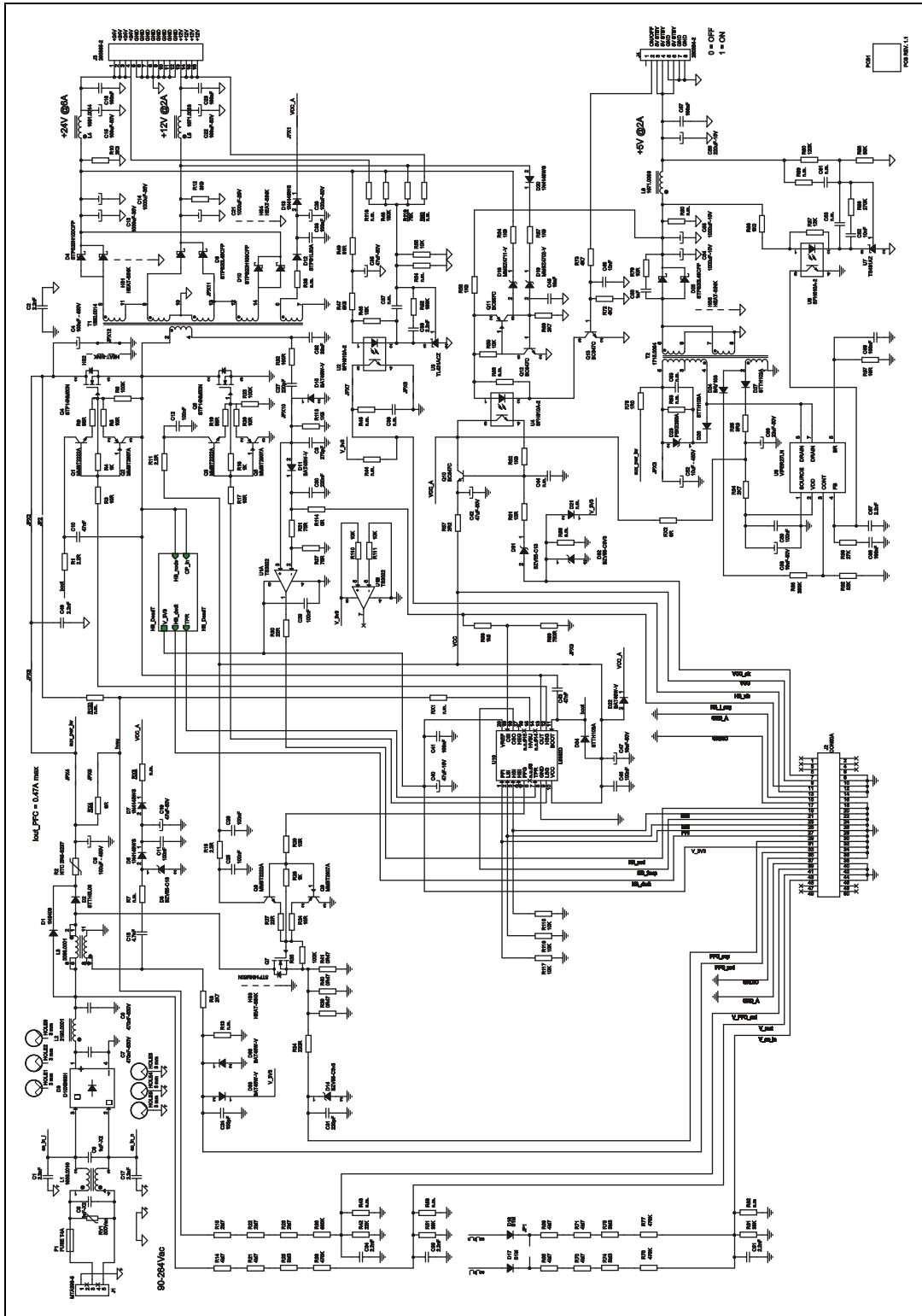

Figure 2. Electrical diagram of dead time block

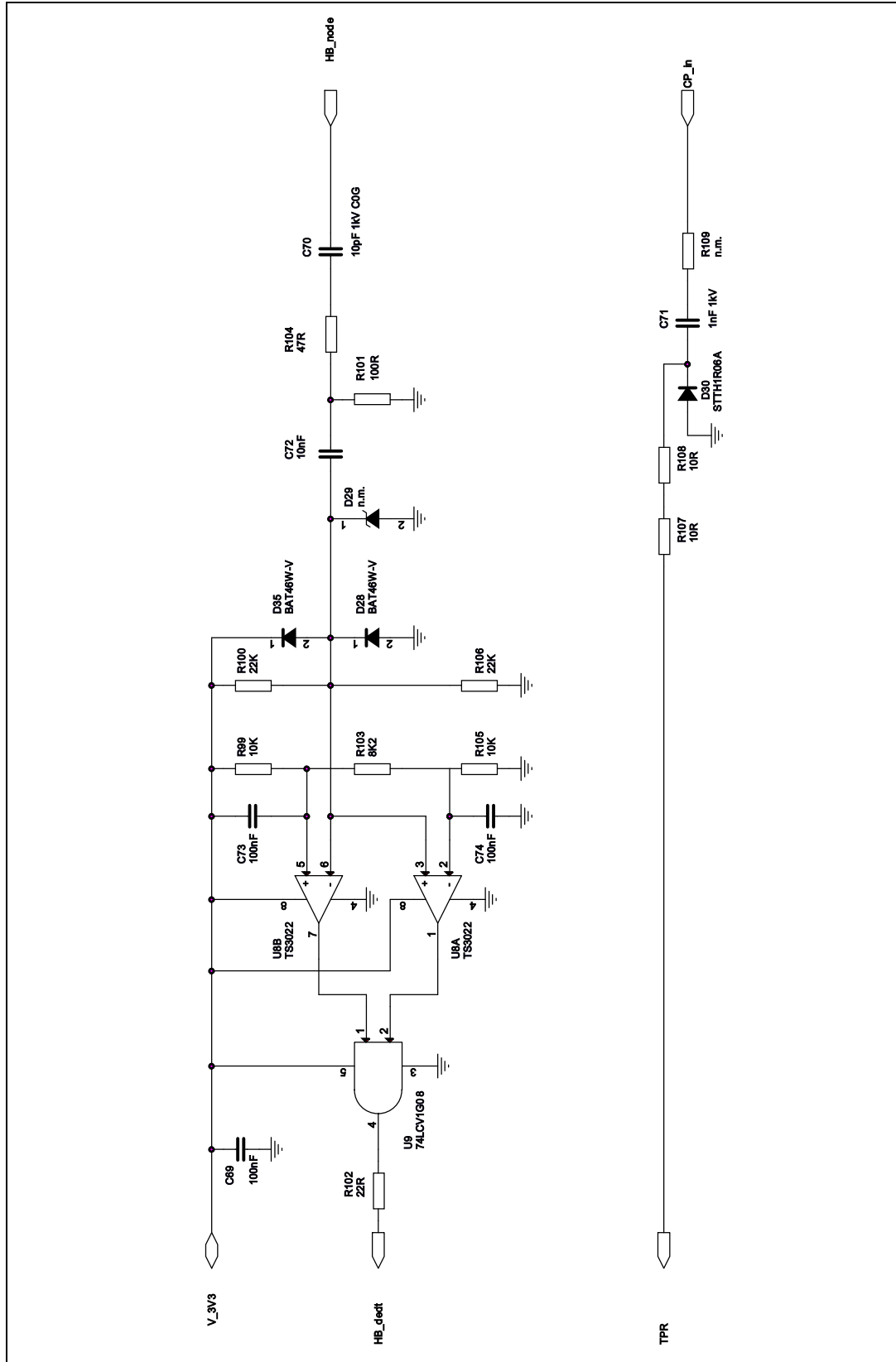





Figure 5. Electrical diagram debug control board - power and interfaces

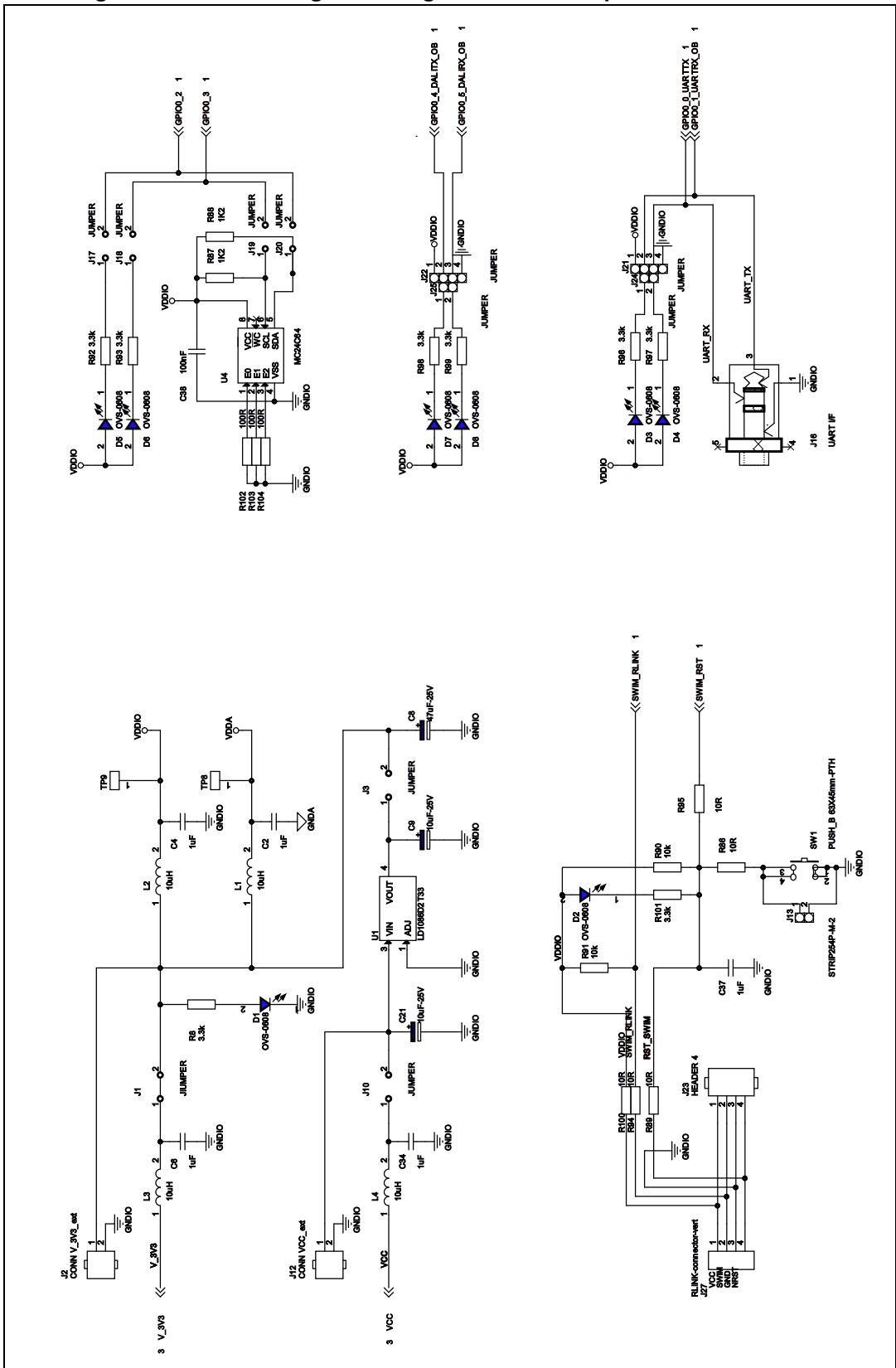
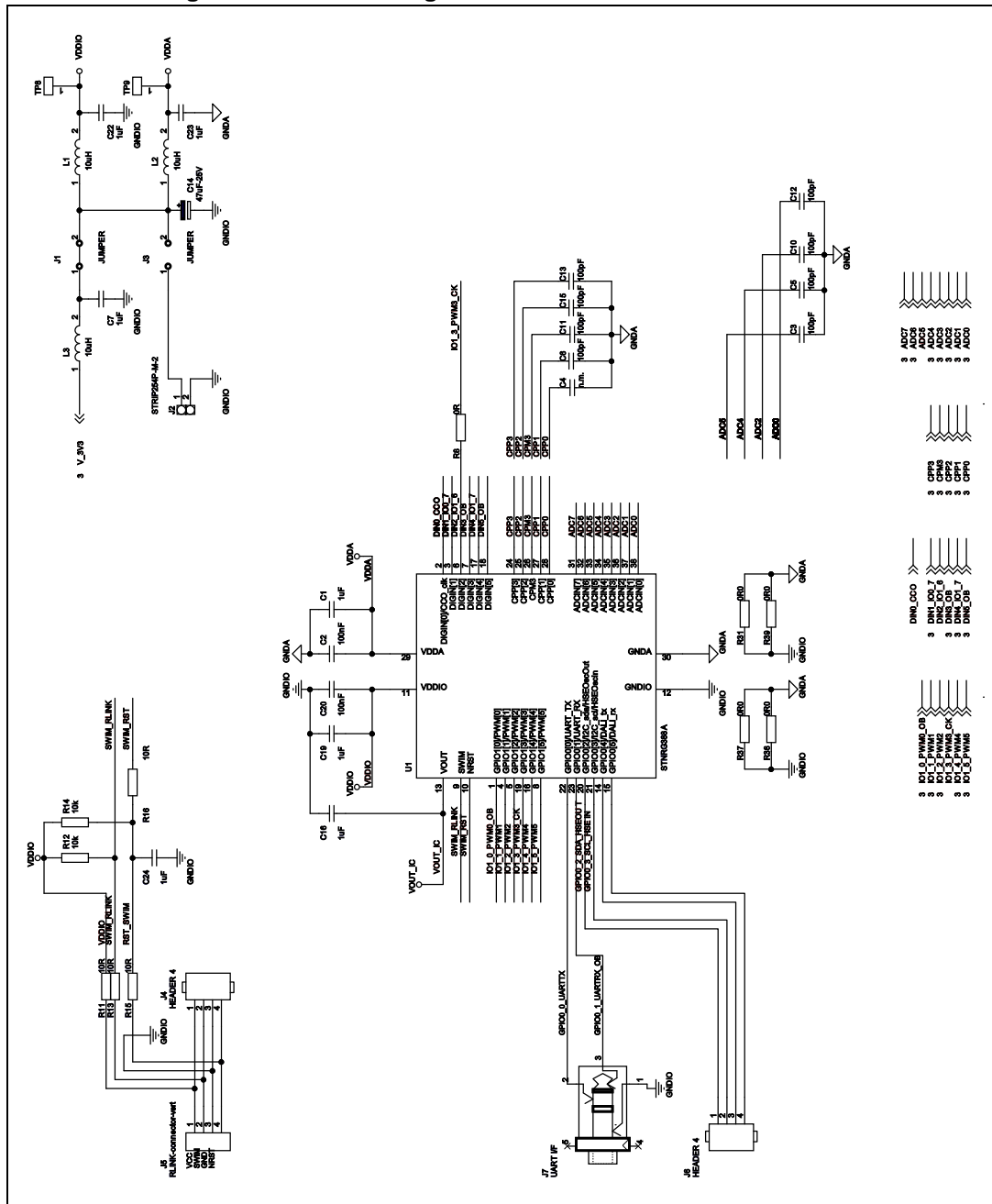

Figure 6. Electrical diagram slim control board - controller







## 2 Revision history

Table 1. Document revision history

Date	Revision	Changes
18-May-2015	1	Initial release.