



EXTENDED VERTICAL LIQUID LEVEL SENSORS

EVS Series

Two position level switching

Mounted on the top wall of a tank

Reliable hermetically sealed reed switches

Body and float made from inert materials

Features

- Full and/or empty detection
- Voltage rating up to 175VDC
- Current rating up to 0.4 amp
- Compact easy to install design
- Optional cable lengths
- Includes mounting hardware

Applications

- Water and fuel storage tanks
- Pump on/off controls
- Marine bilge and ballast tanks
- Flood detection and prevention
- Coolant level indication
- Livestock watering tanks
- Irrigation systems
- Water treatment plants
- Waste water tanks

The EVS series of point liquid level switches demonstrate a high degree of reliability due to the use of non-reactive wetted components and a unique reed switch designed specifically for level sensing applications. The sensor utilizes a moving float with an embedded magnet to activate one of two reed switches located in the sensor body.

As the liquid level raises the float, it moves a magnet from the bottom switch to the top switch. The use of two switches provides an indication of three different level conditions.

The reliability of this sensor results from a very simple operating principle, a single moving part, media compatible wetted materials, and a unique reed switch design.

The sensor mounts into the top wall of a liquid storage tank using an M16 x 2.0 threaded fitting. The M16 mount is available in an internal or external configuration. The outputs are simple N.O. or N.C. SPST reed switches that utilize Ruthenium contact points for reliability. Electrical outputs are three wires with PVC insulation and optional lengths of 0.5 m or 2.0 m.

[CLICK HERE >](#)
CONNECT WITH A SPECIALIST

LIQUID LEVEL SWITCH

EVS Series

Absolute Maximum Ratings⁽¹⁾

Parameter	Min	Max	Units	Notes/Conditions
DC contact voltage		175	V	Do not exceed 5 W
DC contact current		0.4	A	
RMS contact voltage		125	V	
RMS contact current		0.28	A	
Storage and operating temperature	Model 3xx	-30	110	°C
	Model 4xx	-30	60	°C
	Model 7xx	-30	80	°C
Fitting pressure	-1.0	4.7	Bar	Internal tank pressure
Tank wall thickness (Internal mount)	1.0	10	mm	
Tank wall thickness (External mount)	1.0	4.0	mm	

⁽¹⁾Maximum limits the device will withstand without damage

Product Specifications

Parameter	Details & Options
Mounting Orientation	Top entry (Internal or external)
Fitting	M16 x 2.0 Internal or External
Switch Operation	Both switches N.C. when float is at the bottom of the body
Contact Forms	Top switch – Form B (N.C. SPST) Bottom switch – Form A (N.O. SPST)
Contact Material	Ruthenium
Contact resistance (max)	140 mΩ
Housing and Float Material Options	Housing: Nylon 6.6 PVC Brass Float: Glass filled nylon 6.6 PVC Polypropylene
Cable Description	18 AWG 16/0.025mm PVC insulated, UL/CSA/BS6361
Shock	±50g 11ms half sign duration
Vibration	±35g 0 – 500Hz
Ambient Humidity	0 – 95% RH (non-condensing)
Ingress protection	IP68 (wetted surfaces) IP65 (non-wetted surfaces)

LIQUID LEVEL SWITCH

EVS Series

Outline Dimensions

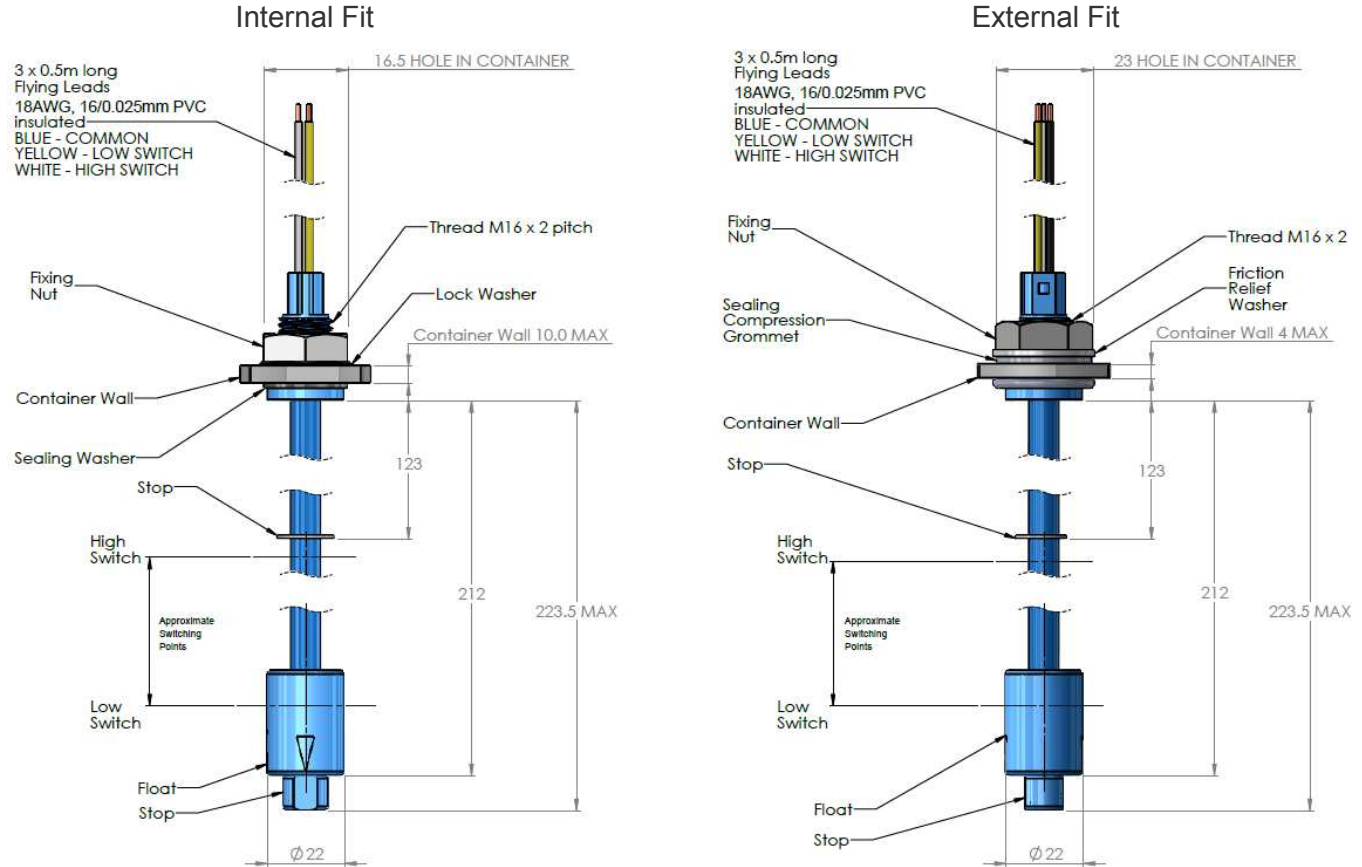

Schematic and Switch Operation

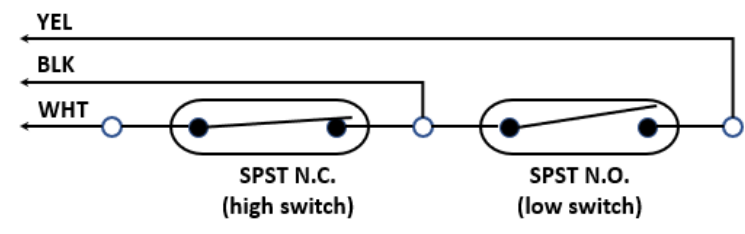

Float Position	High Switch	Low Switch
Top Limit	Open	Open
Between Top and Bottom	Closed	Open
Bottom Limit	Closed	Closed

Mounting Detail & Hardware

INTERNAL FITTING

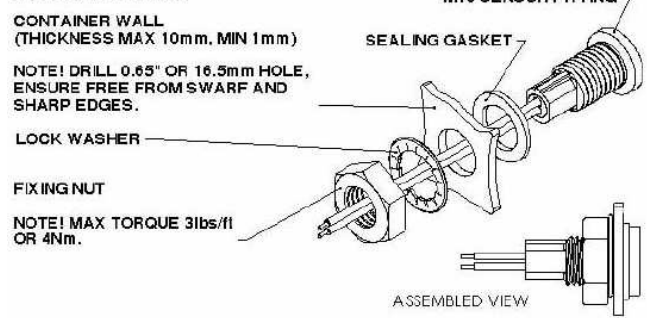

EXTERNAL FITTING

