

Demonstration board for STDRIVEG600 600V high-speed half-bridge gate driver with MDmesh DM2 Power MOSFET

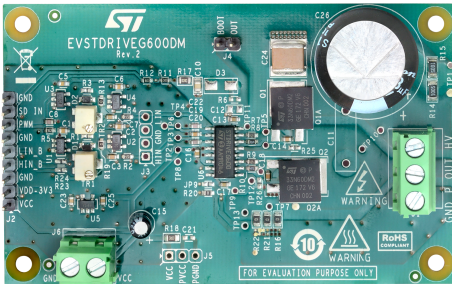

Features

- Half-Bridge topology featuring 600V STDRIVEG600 gate driver
- Equipped with 115 mΩ 600V MDmesh DM2 Power MOSFET STL33N60DM2 with fast recovery diode.
- MOSFET in PowerFLAT 8x8 HV package with Kelvin source or alternative DPAK footprint.
- HV bus up to 450V (capacitor rating limited)
- 4.75 to 20 V VCC gate driver supply voltage
- On-board adjustable deadtime generator to convert single PWM signal into independent high-side and low-side deadtimes.
- Separated inputs with external deadtime can also be used
- On-board 3.3V regulator for external circuitry supply
- 20°C/W junction-to-ambient thermal resistance to evaluate large power topologies
- Optional low-side shunt
- RoHS compliant.

Description

The STDRIVEG600 is a high-speed half-bridge gate driver optimized to drive high-voltage N-channel power MOSFETs or enhanced mode GaN HEMTs. It features an integrated bootstrap diode and allows supplying external switches up to 20 V.

The [EVSTRIVEG600DM](#) board is easy to use and quick and adapt for evaluating the characteristics of STDRIVEG600 driving 600V MDmesh DM2 Power MOSFET with fast recovery diode.

It provides an on-board programmable dead time generator and a 3.3 V linear voltage regulator to supply external logic controllers like microcontrollers.

Spare footprints are also included to allow customizing the board for the final application, such as separate input signal or single PWM signal, use of optional external bootstrap diode, separate supply for VCC, PVCC or BOOT and the use of low-side shunt resistor for peak current mode topologies.

The [EVSTRIVEG600DM](#) is 54 x 88 mm wide, FR-4 PCB resulting in 20 °C/W $R_{th(J-A)}$ in still air.

Product status link

[EVSTRIVEG600DM](#)

1 Safety and operating instructions



1.1 General terms

Warning:

During assembly, testing, and operation, the demonstration board poses several inherent hazards, including bare wires, moving or rotating parts and hot surfaces.

Danger:

There is danger of serious personal injury, property damage or death due to electrical shock and burn hazards if the kit or components are improperly used or installed incorrectly.

The kit is not electrically isolated from the high-voltage supply DC input. No insulation is ensured between the accessible parts and the high voltage. All measuring equipment must use adequately insulated probes, clamps and connecting wires. Never touch the evaluation board while it is energized as it is capable of causing electrical shock hazard.

All operations involving transportation, installation and use, and maintenance must be performed by skilled technical personnel able to understand and implement national accident prevention regulations. For the purposes of these basic safety instructions, “skilled technical personnel” are suitably qualified people who are familiar with the installation, use and maintenance of power electronic systems.

1.2 Intended use of demonstration board

The board is designed for demonstration purposes only, and must not be used for electrical installations or machinery. Technical data and information concerning the power supply conditions are detailed in the documentation and should be strictly observed.

1.3 Installing the demonstration board

- The installation and cooling of the demonstration board must be in accordance with the specifications and target application.
- The board must be protected against excessive strain. In particular, components should not be bent or isolating distances altered during transportation or handling.
- No contact must be made with other electronic components and contacts.
- The board contains electrostatically-sensitive components that are prone to damage if used incorrectly. Do not mechanically damage or destroy the electrical components (potential health risks).

1.4 Operating the demonstration board

To operate properly the board, follow these safety rules.

1. Work Area Safety:
 - The work area must be clean and tidy.
 - Do not work alone when boards are energized.
 - Protect against inadvertent access to the area where the board is energized using suitable barriers and signs.
 - A system architecture that supplies power to the evaluation board must be equipped with additional control and protective devices in accordance with the applicable safety requirements (i.e., compliance with technical equipment and accident prevention rules).
 - Use non-conductive and stable work surface.
 - Use adequately insulated clamps and wires to attach measurement probes and instruments.
2. Electrical Safety:
 - Remove power supply from the board and electrical loads before performing any electrical measurement.
 - Proceed with the arrangement of measurement setup, wiring or configuration paying attention to high voltage sections.
 - Once the setup is complete, energize the board.

Danger:

Do not touch the board when it is energized or immediately after it has been disconnected from the voltage supply as several parts and power terminals containing potentially energized capacitors need time to discharge.

Do not touch the boards after disconnection from the voltage supply as several parts, included PCB, may still be very hot.

The kit is not electrically isolated from the DC input.

3. Personal Safety
 - Always wear suitable personal protective equipment such as, for example, insulating gloves and safety glasses.
 - Take adequate precautions and install the board in such a way to prevent accidental touch. Use protective shields such as, for example, insulating box with interlocks if necessary.

2 Schematic diagrams

Figure 1. EVSTRIVEG600DM schematic - STRIVEG600 driver, power stage and connectors

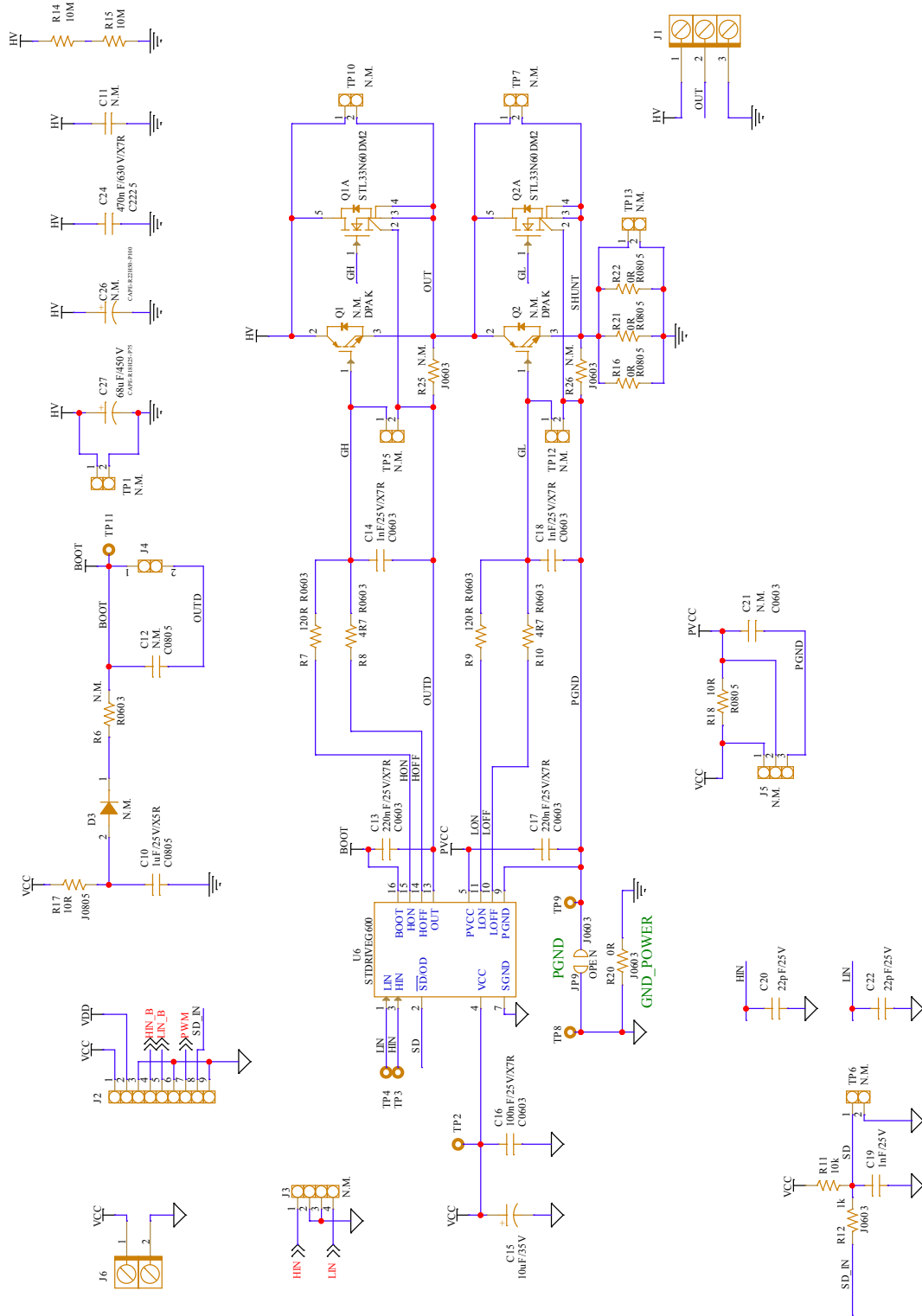

3 Board power-up and input connection

The following picture shows how to supply the EVSTDRIVEG600DM, how to provide LIN and HIN inputs and set the programmable deadtime generator.

Figure 3. EVSTDRIVEG600DM - Supply and signal connection

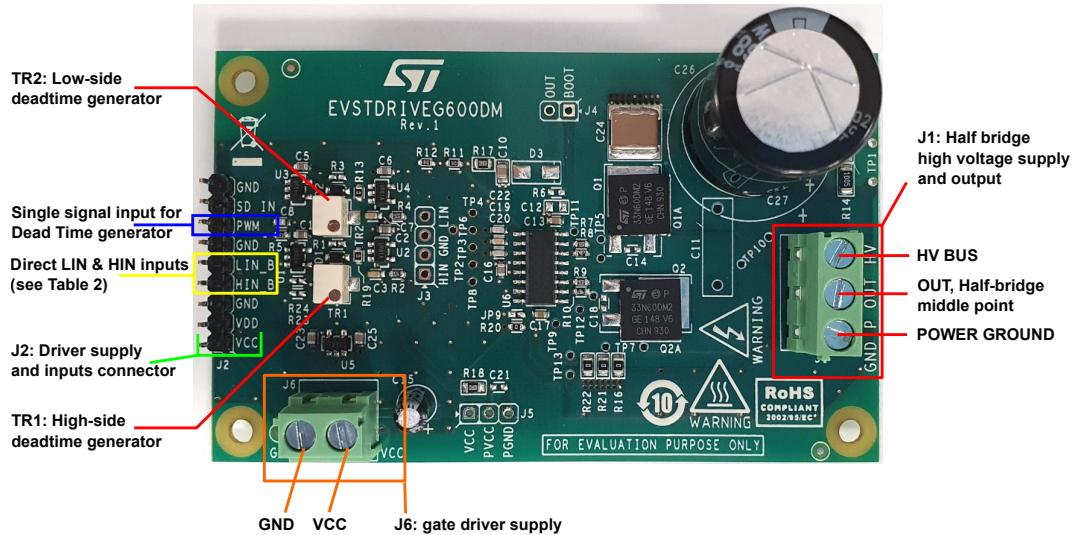

The LIN, HIN inputs can be provided from the on-board deadtime generator or directly from an external generator or control device (such as DSP/MCU).

The deadtime value set by the on-board deadtime generator, fed by PWM input signal on J2, can be tuned by setting TR1 and TR2. The typical deadtime value with the trimmer in the default manufacturing middle position is about 400 ns. It is possible to change deadtime generator range by changing C3 and C7.

TR2 sets the deadtime before low side turn-on.

TR1 sets the deadtime before high side turn-on.

Table 1. Connector Map

Ref	Pin #	Name	Function	Description
J1	1	HV	INPUT Power	High voltage (HV) of power stage. Connect the half bridge high voltage positive supply.
	2	OUT	OUTPUT Power	OUT of half bridge power stage: connect the load to this terminal.
	3	GND_P	PWR	Power ground of power stage. Connect the half bridge high voltage negative supply.
J2	1	VCC	INPUT Power	Board Supply voltage (recommended value 15 V)
	2	VDD (3V3)	OUT power	Output voltage of on-board 3.3 V regulator: it can be used to supply external circuitry (up to about 20 mA)
	3	GND	PWR	Board reference potential
	4	HIN_B	OUT digital	HIN direct input signal (0 to 3.3 V or up to 20 V): mount R23 and remove R2 - see Table 2 and Table 3
	5	LIN_B	OUT digital	LIN direct input signal (0 to 3.3 V or up to 20 V): mount R24 and remove R4 - see Table 2 and Table 3
	6	GND	PWR	Board reference potential
	7	PWM	INPUT digital	PWM input signal (0 to 3.3 V or 5 V) – see Table 3

Ref	Pin #	Name	Function	Description
J2	8	SD_IN	INPUT / OUT digital	Disable input signal (0 to 3.3 V or up to 20 V) – see Table 3 Open-drain output signal over-temperature protection
	9	GND	PWR	Board reference potential
J6	1	VCC	INPUT Power	Board Supply voltage (recommended value 15 V)
	2	GND	POWER	Board reference potential

Table 2. Device input selection

R2, R4	R23, R24	Input source	Function and description
0-47 Ω (closed)	Open	J2: PWM pin	LIN & HIN are generated by the on-board deadtime generator from a single PWM signal on J2, pin 7.
Open	0-47 Ω (closed)	J2: LIN & HIN pin	Direct connection to LIN and HIN STDRIVEG600 pins. LIN, HIN input range: up to 20 V.

Table 3. Input signal truth table

$\overline{\text{SD/OD}}$	PWM	LIN	HIN
L	X	L	L
H	L	H	L
H	H	L	H

The recommended power-on sequence is to turn VCC on first, then apply the HV bus voltage. The recommended power-off sequence is to turn-off the HV bus supply first, then VCC.

4 Bill of materials

Table 4. EVSTRIVEG600DM bill of materials

Reference	Description	Value or Generic Part Number Package
C1, C2, C5, C6, C23, C25	SMT ceramic capacitor	100 nF / 25 V / X7R, 0603
C3, C7, C14, C18	SMT ceramic capacitor	1 nF / X7R, 0603
C8, C20, C22	SMT ceramic capacitor	22 pF / 25 V, 0603
C10	SMT ceramic capacitor	1 μF / 25 V / X5R, 0805
C11	Film capacitor or Metallized polypropylene	N.M., pitch 10 mm
C12	SMT ceramic capacitor	N.M., 0805
C13, C17	SMT ceramic capacitor	220 nF / 25 V / X7R, 00603
C15	THT Electrolytic Capacitor	10 μF / 35V, D5 P2.5 mm
C19	SMT ceramic capacitor	1 nF / 25 V, 0603
C21	SMT ceramic capacitor	N.M., 0603
C24	SMT ceramic capacitor	470 nF / 630 V / X7R, 2225
C26	THT Electrolytic Capacitor	N.M, D22 P10 mm
C27	THT Electrolytic Capacitor	68 μF / 450 V, D18 P7.5 mm
D1, D2	Low capacitance, low series inductance and resistance Schottky diodes	BAS70JFILM, SOD-323
D3	Fast Rectifiers	N.M., SMA
JP9	SMT jumper	OPEN, Soldering pads
J1	Terminal block T.H. 3 pos, 5.08 mm	3 Poles, Pitch 5.08 mm
J2	Strip connector 9 pos, 2.54 mm	STRIP 1x9
J3	Strip connector 4 pos, 2.54 mm	N.M.
J4	Strip connector 2 pos, 2.54 mm	STRIP 1x2
J5	Strip connector 3 pos, 2.54 mm	N.M.
J6	Terminal block T.H. 2 pos, 5.08 mm	2 Poles, Pitch 5.08 mm
Q1A, Q2A	N-channel 600 V, 0.115 Ω typ., 21 A MDmesh DM2 Power MOSFET	STL33N60DM2, PowerFLAT 8x8 HV
Q1, Q2	DPAK power switch	DPAK
R1, R3, R6, R23, R24, R25, R26	SMT resistor	N.M., 0603
R2, R4	SMT resistor	47 Ω, 0603
R5	SMT resistor	47 kΩ, 0603
R7, R9	SMT resistor	120 Ω, 0603
R8, R10	SMT resistor	4,7 Ω, 0402
R11	SMT resistor	10 kΩ, 0603
R12	SMT resistor	1 kΩ, 0603
R13, R19, R20	SMT resistor	0 Ω, 0603
R14, R15	SMT resistor	10 MΩ, 1206
R16, R21, R22	SMT resistor	0 Ω, 0805
R17, R18	SMT resistor	10 Ω, 0805

Reference	Description	Value or Generic Part Number Package
TP1, TP7, TP10	Test point for probe	Pitch 5.08 mm
TP2, TP3, TP4, TP8, TP9, TP11	Test point for probe	Metallized Hole 0.8 mm
TP5, TP6, TP12, TP13	Test point for probe	Pitch 2.54 mm
TR1, TR2	5 mm Square Surface Mount Miniature Trimmers Multi-Turn Cermet Sealed	1 k Ω , TSM4YJ
U1, U2, U4	Single Schmitt-Trigger buffer	74LVC1G17W5, SOT23-5L
U3	Single Schmitt-Trigger inverter	74LVC1G14W5, SOT23-5L
U5	High input voltage, 85 mA LDO linear regulator	ST715M33R, SOT23-5L
U6	High voltage and high-speed half-bridge gate driver	STDRIVEG600, SO16

5 Layout and component placements

Figure 4. EVSTDRIVEG600DM - Layout (component placement top view)

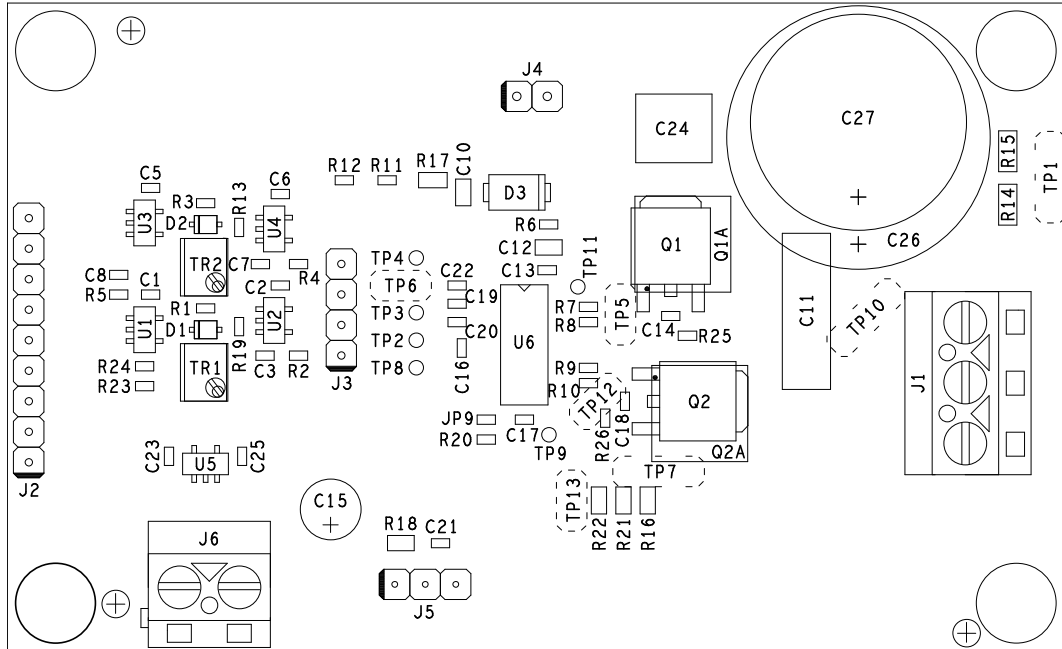

Figure 5. EVSTDRIVEG600DM - Layout (top layer)

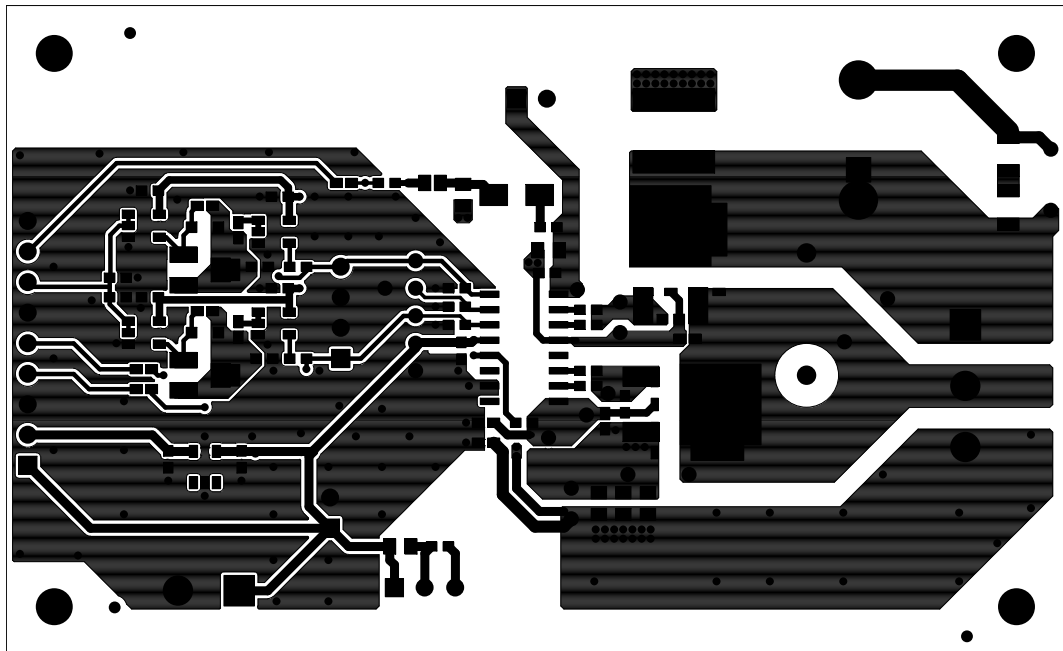
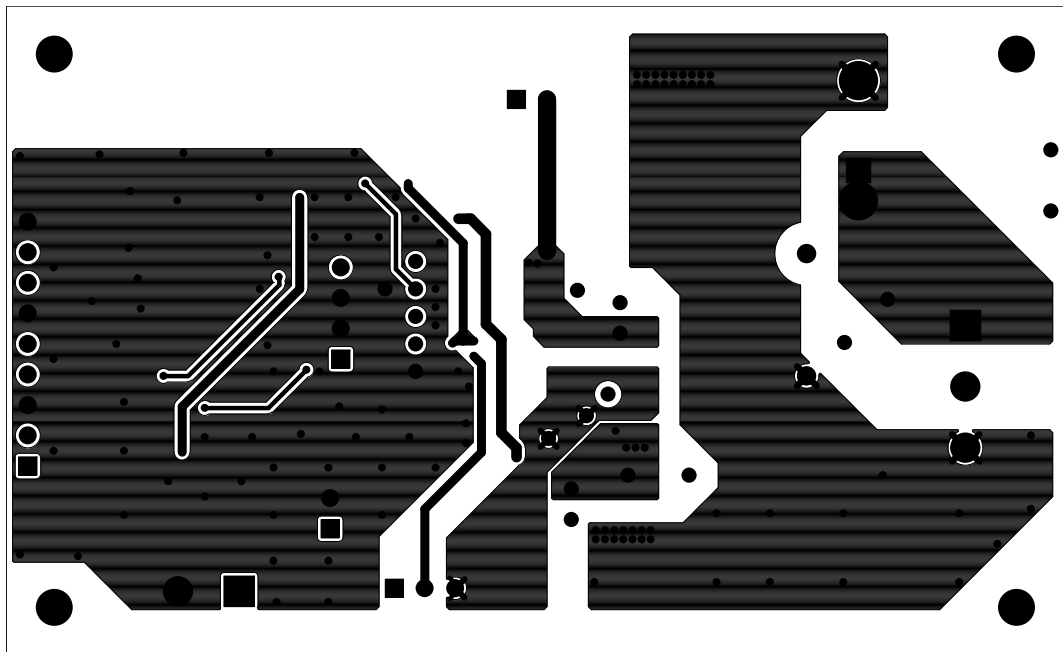

Figure 6. EVSTDRIVEG600DM - Layout (bottom layer)



Revision history

Table 5. Document revision history

Date	Version	Changes
21-Jun-2021	1	Initial release.

Contents

1	Safety and operating instructions	2
1.1	General terms	2
1.2	Intended use of demonstration board	2
1.3	Installing the demonstration board	2
1.4	Operating the demonstration board	3
2	Schematic diagrams	4
3	Board power-up and input connection	6
4	Bill of materials	8
5	Layout and component placements	10
	Revision history	12
	Contents	13
	List of tables	14
	List of figures	15

List of tables

Table 1.	Connector Map	6
Table 2.	Device input selection.	7
Table 3.	Input signal truth table	7
Table 4.	EVSTDRIVEG600DM bill of materials.	8
Table 5.	Document revision history	12

List of figures

Figure 1.	EVSTDRIVEG600DM schematic - STDRIVEG600 driver, power stage and connectors	4
Figure 2.	EVSTDRIVEG600DM schematic - Deadtime generator	5
Figure 3.	EVSTDRIVEG600DM - Supply and signal connection	6
Figure 4.	EVSTDRIVEG600DM - Layout (component placement top view).	10
Figure 5.	EVSTDRIVEG600DM - Layout (top layer)	10
Figure 6.	EVSTDRIVEG600DM - Layout (bottom layer).	11