

NOTES:

1. ROHS COMPLIANT
2. HEADER: PHENOLIC WITH FLAMMABILITY RATING UL 94V-0 OR BETTER.
3. STORAGE TEMPERATURE: -50°C TO +125°C
4. COMPLIANCE TO J-STD:
 - A. J-STD-002: SOLDERABILITY AT 245°C REFLOW PROFILE
 - B. J-STD-020: LEVEL 1, NO MOISTURE SENSITIVE
 - C. J-STD-075: R7, 245°C MAXIMUM THROUGH REFLOW SOLDER
5. TO ORDER TAPE & REEL PACKAGING ADD A "T" SUFFIX TO THE PART NUMBER(i.e EX2024FNL BECOMES EX2024FNLT).

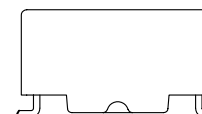
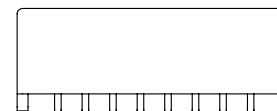

FINAL OUTLINE

© Copyright, 2014. Pulse Electronics Corp. All rights reserved. Pulse confidential & proprietary. (06/11/14)

| PRODUCT DESCRIPTION | TLA DRAWING | PS DRAWING | SHEET | PART NO. | DATASHEET REV. |
|-------------------------|--------------|---------------|--------|-----------|----------------|
| MDL,SIN,10D,1:2.5,SM,TU | EX2024FNL-10 | PS-2753.001-A | 1 OF 3 | EX2024FNL | A |

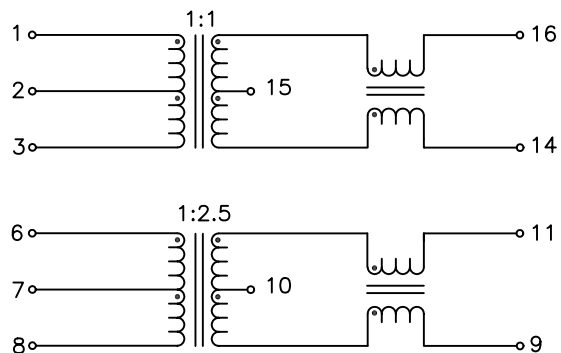

SCHEMATIC – PINS 4, 5, 12 AND 13 NOT CONNECTED

ELECTRICAL CHARACTERISTICS AT +25°C UNLESS OTHER SPECIFIED

| PARAMETER | SPECIFICATIONS | | | |
|--|---|------------|------------|------------|
| OPERATING TEMPERATURE | -40°C ~ +85°C | | | |
| POLARITY | PER SCHEMATIC | | | |
| URNS RATIO | (6-8):(11-9) = 1:2.5 ±3% (1-3):(16-14) = 1:1 ±3% | | | |
| INDUCTANCE (OCL) (MEDIA SIDE, -40°C~85°C) | (1-3) = 200 uH MIN (AT 100 KHz 20 mVRMS) (6-8) = 35 uH MIN | | | |
| CAPACITANCE WINDING TO WINDING | 30 pF MAX (AT 100 KHz 20 mVRMS) | | | |
| COMMON MODE REJECTION RATIO | 1 MHz | 30 MHz | 40 MHz | 100 MHz |
| | -50 dB MIN | -50 dB MIN | -40 dB MIN | -40 dB MIN |
| DC RESISTANCE | 2.0 OHMS MAX | | | |
| LEAKAGE INDUCTANCE | 0.8 uH MAX | | | |
| INPUT – OUTPUT ISOLATION | 1500 VRMS MIN @ 60 SECONDS | | | |

NOTE: f IS FREQUENCY IN MHz.

© Copyright, 2014. Pulse Electronics Corp. All rights reserved. Pulse confidential & proprietary. (06/11/14)

| PRODUCT DESCRIPTION | TLA DRAWING | PS DRAWING | SHEET | PART NO. | DATASHEET REV. |
|-------------------------|--------------|---------------|--------|-----------|----------------|
| MDL,SIN,10D,1:2.5,SM,TU | EX2024FNL-10 | PS-2753.001-A | 2 OF 3 | EX2024FNL | A |