



# I-temp CFexpress

(CFexpress, TLC, Industrial)

**Product Datasheet**

PCIe Gen 3 x 2

Commercial Temperature Grade -40°C ~ 85°C

## Revision History

Revision	Description	Date
001	First Released	March, 2022
002	Add 128GB and update performance	October, 2022
003	Update product feature	January, 2023

# I-temp CFexpress

## Product Specification

- **Capacity**
  - 128GB~1TB
- **Components**
  - Controller: Marvell 88SS1321
  - Flash: 3D TLC
  - DRAM: DDR3/DDR4
- **Compliance**
  - PCIe Gen 3 x 2  
(Support Upgrade to Gen 4 x 2)
- **Performance\***
  - Sustained Read: 1,800 MB/s
  - Sustained Write: 1,500 MB/s
  - Random Read: 200,000 IOPS
  - Random Write: 180,000 IOPS
- **Power Management**
  - Temperature monitoring and throttling
- **Reliability**
  - Advanced LDPC error correction
  - Global static and dynamic wear leveling
  - UBER: <1 sector per  $10^{17}$  bits read
  - MTBF: 2.0 Million Hours
- **Endurance**
  - TBW : 600TB with 1TB  
300TB with 512GB  
150TB with 256GB  
75TB with 128GB
- **Security**
  - Full disk encryption (FDE) as self-encrypting drive (SED) with TCG Opal 2.0
- **Data Retention**
  - JESD47 Compliant
- **Compatibility**
  - Windows 11/10
  - Windows Server 2016/2012 R2/2012
  - CentOS, Fedora, FreeBSD, openSUSE, Red Hat, Ubuntu
  - VMware ESXi, Citrix, KVM
- **Mechanical Form Factor**
  - 29.6 mm x 38.5 mm x 3.8 mm
- **Power Consumption (TYP)**
  - Active: < 4.5W
  - Idle: < 0.8W
- **Environment**
  - Operating temperature: -40°C ~ 85°C
  - Storage temperature: -45°C ~ 90°C
- **Shock & Vibration**
  - Operating:  
50G (11ms duration, half sine wave)
  - Non-Operating:  
1500G (0.5ms duration, half sine wave)
  - Vibration: 10G (Peak, 10~2000Hz)
- **Warranty**
  - 3 years

Specifications subject to change without notice.

(1) Actual performance may vary based on hardware, software, and overall system configuration.

(2) Sequential performance is measured with 128KB transfer size, QD 32 and 4KB align with IO Meter.

(3) Random performance is sustained performance measured with 4K/8K transfer size, QD 32 and 4KB align with IO Meter.

(4) Performance Test Platform: CPU - Intel Core i7 4770K, Mother Board - ASUS Z87-DELUXE, Chipset - Intel Z87 Express, OS - Windows 8.1 Pro x64

(5) Access patterns used for random workload during endurance testing is compliant with the JESD219 standard

# Contents

Revision History	2
Contents	4
1. Ordering Information	5
2. Product Overview	6
3. Product Specifications	7
3.1 Capacity	7
3.2 Performance	8
3.3 Environment Specification	9
3.4 Power Consumption	10
3.5 Reliability	10
4. Physical Dimension Diagram	11
4.1 CFexpress Board (Type-B)	11
5. Pin Assignment	12
5.1 CFexpress Board (Type-B)	12
6. Standards Compliance	13
7. Supported NVMe Commands	14
8. S.M.A.R.T Support	15
8.1 Overview of S.M.A.R.T Support	15
8.2 S.M.A.R.T Health Information	15
Limited Warranty Policy	18
Warranty Terms	19
Contact Information	20

# 1. Ordering Information

The following Tables list the PN for Exascend I-temp CFexpress

Table 1 I-temp CFexpress product list

Part Number	Capacity	Flash Type	Form Factor
EXPC3S128GB-I	128GB *	3D TLC	CFexpress Type-B
EXPC3S256GB-I	256GB *	3D TLC	CFexpress Type-B
EXPC3S512GB-I	512GB *	3D TLC	CFexpress Type-B
EXPC3S001TB-I	1TB **	3D TLC	CFexpress Type-B

\*1GB=1,000,000,000 Bytes

\*\*1TB=1,024GB

# 2. Product Overview

Exascend provides customizable hardware and firmware design, manufacturing, and service of cutting-edge SSD products and advanced storage systems. Our products are designed specifically for high reliability commercial, enterprise data center, and cloud computing applications. By combining world class design R&D, and superior execution in delivery and support capabilities, Exascend strives to provide customers with the best in class product and service, enabling enhanced boot times, faster application load times, reduced power consumption and extended reliability.

I-temp CFexpress series product supports CFexpress Type-B form factors, integrating high speed PCIe Gen 3 x 2 interface with 3D TLC NAND flash memory technology (support upgrade to Gen 4 x 2 also), delivering capacities up to 1TB.

I-temp CFexpress series products are offered in two product categories with different over-provisioning. Key product highlights include:

- High I/O and throughput performance
- Next generation LDPC technology secures NAND endurance
- Advanced Flash management and global wear leveling algorithm extending drive life
- High stability and reliability
- Temperature monitoring and throttling

### 3. Product Specifications

Exascend I-temp CFexpress series provides you the ultimate performance and ultra-high reliability over traditional hard disk drive by achieving up to 1800MB/s for sustained read, 1200MB/s for sustained write, 300,000IOPS for random read, 250,000IOPS for random write.

Exascend I-temp CFexpress series consists solely of semiconductor devices; it does not contain any mechanical part such as platter (disk), motor and suspension as traditional hard disk drive. Thus, it exhibits superior performance, capacity, reliability, ruggedness, low power, and small form factor profiles that qualified to be the best storage solution for enterprise application with extreme workloads and increased MTBF requirements.

Exascend I-temp CFexpress uses a single-chip Flash controller to manage multiple NAND Flash memory modules. The controller works with a host system to allow data to be written to and read from the Flash memory modules through a PCIe interface.

### Capacity

Table 2 User Addressable Sectors

I-temp CFexpress Series	Unformatted Capacity (Total User Addressable Sectors in LBA mode)
128GB	250,069,680
256GB	500,118,192
512GB	1,000,215,216
1TB	2,000,409,264

Notes:

- (1) LBA count shown represents total user storage capacity and will remain the same throughout the life of the drive.
- (2) The total usable capacity of the SSD may be less than the total physical capacity because a small portion of the capacity is used for NAND flash management and maintenance purposes.

### Performance

Table 3 Drive Performance

Parameter	Capacity				Unit
	128GB	256GB	512GB	1TB	
Sustained Read	800	1,200	1,800	1,800	MB/s
Sustained Write	200	400	750	1,500	MB/s
Random Read	25,000	55,000	110,000	200,000	IOPS
Random Write	50,000	95,000	170,000	180,000	IOPS

Specifications subject to change without notice.

Notes:

- (1) Drive is connected as secondary
- (2) Actual performance may vary based on hardware, software, and overall system configuration.
- (3) Sequential performance is measured with 128KB transfer size, QD 32 and 4KB align with IO Meter.
- (4) Random performance is sustained performance measured with 4K/8K transfer size, QD 32 and 4KB align with IO Meter.

(5) Test Platform: CPU - Intel Core i7 4770K, Mother Board - ASUS Z87-DELUXE, Chipset - Intel Z87 Express, OS - Windows 8.1 Pro x64

## Environment Specification

Table 4 Environmental Specification Table

Parameter	Value
Operating Temperature	-40° ~ 85° C
Storage Temperature	-45° ~ 90° C
Power Supply Voltage Range	3.3V ± 5%
Humidity (non-condensing)	5%~95% (Operating)
Vibration	10G(Peak,10~2000Hz)
Shock (Operating)	50G, (11ms duration, half sine wave)
Shock (Non-Operating)	1500G, (0.5ms duration, half sine wave)

## Power Consumption

Table 5 Power Consumption Table

Parameter	Unit	I-temp CFexpress Series
Active Power (Average)	W	<4.5
Idle Mode Power (Average)	W	<0.8

## Reliability

I-temp CFexpress series products meet or exceed SSD endurance and data retention requirements as specified in the JESD218 standard. Reliability specifications are listed in the following table

Parameter	Value
<b>Mean Time Between Failures (MTBF)</b> Mean Time Between Failures is a measure of how reliable a hardware product of component is. It's the mean time between failures which describe the expected time between two failures. It is tested through reliability demonstration test (RDT).	2,000,000 hours
<b>Uncorrectable Bit Error Rate (UBER)</b> Uncorrectable bit error rate will not exceed one sector in the specified number of bits read. In the unlikely event of a non-recoverable read error ,the SSD will report it as a read failure to the host; the sector in error is considered corrupt and is not returned to the host	$<10^{-17}$
<b>Endurance Rating (TBW)</b> TBW stands for total bytes written whose access pattern is compliant with JESD218 standard.	128GB: 75TB 256GB: 150TB 512GB: 300TB 1TB: 600TB



## 4. Physical Dimension Diagram

### 4.1 CFexpress Board (Type-B)

Figure 1: Physical Dimension Diagram for CFexpress board (Type-B)

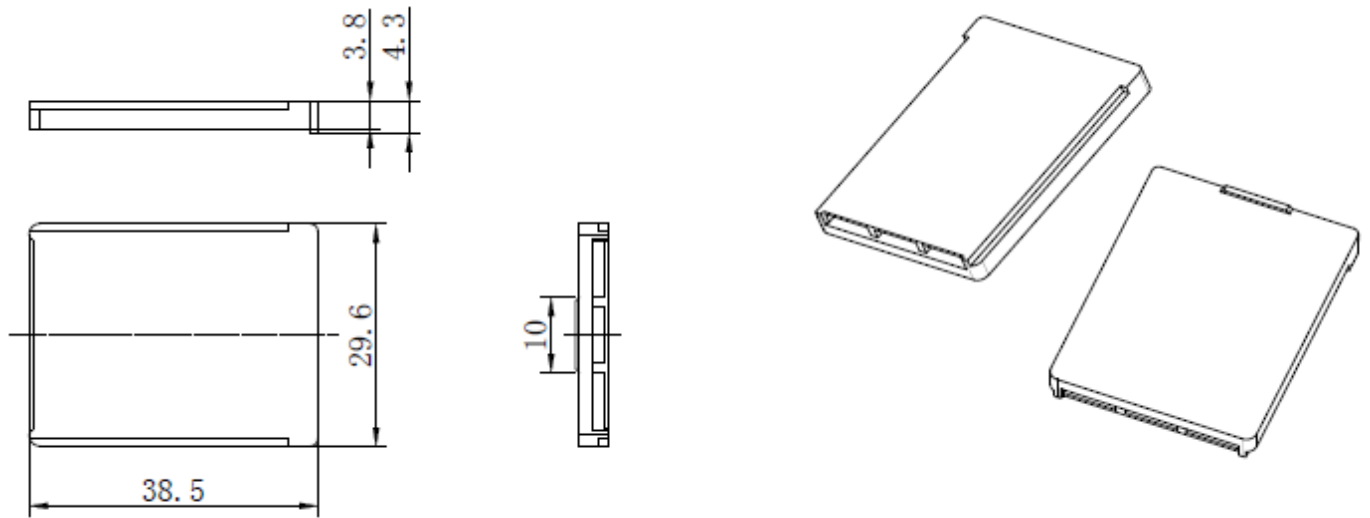

Table 5 Physical Dimension for CFexpress board (Type-B)

Physical Dimensions	Value	Unit
Length	29.6	mm
Width	38.5	mm
Thickness	3.8	mm

## 5. Pin Assignment

### 5.1 CFexpress Board (Type-B)

Table6 Pin assignment and description for signal and power pins for CFexpress Board (Type-B)

Number	Name	Description
P1	GND	Ground
P2	PERn1	PCIe RX Differential signals lane1
P3	PERp1	
P4	GND	
P5	PETn1	PCIe TX Differential signals lane1
P6	PETp1	
P7	NC	
P8	NC	NO Connect
P9	PERST#	PE-Reset is a functional reset to the card
P10	3.3V	3.3V source
P11	CLKREQ#	Clock Request is a reference clock request signal
P12	INS#	NO Connect
P13	REFCLKn	PCIe Reference Clock signals(100MHz)
P14	REFCLKp	
P15	GND	
P16	PERn0	PCIe RX Differential signals lane0
P17	PERp0	
P18	GND	
P19	PETn0	PCIe TX Differential signals lane0
P20	PETp0	
P21	GND	

## 6. Standards Compliance

Exascend I-temp CFexpress series complies with following standards:

FCC

CE

RoHS

## 7. Supported NVMe Commands

Exascend I-temp CFexpress series supports NVMe commands that are shown as following table. For details of the NVMe command, please refer to the NVMe 1.2 command set.

Table 6 Admin Commands

Command Name	Code (Hex)	Command Name	Code (Hex)
Delete I/O Submission Queue	00h	Abort	08h
Delete I/O Completion Queue	01h	Set Features	09h
Get Log Page	02h	Get Features	0Ah
Create I/O Submission Queue	04h	Asynchronous Event Request	0Ch
Create I/O Completion Queue	05h	Firmware Commit	10h
Identify	06h	Firmware Image Download	11h

Table 7 I/O Commands

Command Name	Code (Hex)	Command Name	Code (Hex)
Flush	00h	Compare	05h
Write	01h	Dataset Management	09h
Read	02h	Write Zeroes	08h
Write Uncorrectable	04h		

Table 8 Get Log Page Commands

Command Name	Code (Hex)	Command Name	Code (Hex)
Reserved	00h	SMART / Health Information	02h
Error Information	01h	Firmware Slot Information	03h

## 8. S.M.A.R.T Support

### 8.1 Overview of S.M.A.R.T Support

Data storage drives capture a variety of information during operation that may be used to analyze drive “health.” Drive manufacturers have adopted S.M.A.R.T. (Self-Monitoring, Analysis, and Reporting Technology) to help warn system software, a system administrator, or a user of impending drive failure, while time remains to take preventive action. The technical documentation for S.M.A.R.T. is captured in the AT Attachment (ATA) standard. The standard defines the protocols for reporting errors and for invoking self-tests to collect and analyze data on demand. The ATA specification is flexible and provides for individual manufacturers to define their own unique vendor specific information. This section describes the baseline S.M.A.R.T. Commands and Attributes supported by the EXP4M6 series products. The information herein should be used in conjunction with the ATA standard and related documents, which may serve as references for topics and details not addressed here. Further, it is recommended to consult the list of public S.M.A.R.T. Attributes.

### 8.2 S.M.A.R.T Health Information

Table 12 S.M.A.R.T Health Information

Byte	Description
00	Critical Warning: This field indicates critical warnings for the state of the controller. Each bit corresponds to a critical warning type; multiple bits may be set. If a bit is cleared to ‘0’, then that critical warning does not apply. Critical warnings may result in an asynchronous event notification to the host. Bits in this field represent the current associated state and are not persistent.
2:1	Composite Temperature: Contains a value corresponding to a temperature in degrees Kelvin that represents the current composite temperature of the controller and namespace(s) associated with that controller. The manner in which this value is computed is implementation specific and may not represent the actual temperature of any physical point in the NVM subsystem. The value of this field may be used to trigger an asynchronous event (refer to section 5.14.1.4). Warning and critical overheating composite temperature threshold values are reported by the WCTEMP and CCTEMP fields in the Identify Controller data structure in Figure 90.
3	Available Spare: Contains a normalized percentage (0 to 100%) of the remaining spare capacity available.
4	Available Spare Threshold: When the Available Spare falls below the threshold indicated in this field, an asynchronous event completion may occur. The value is indicated as a normalized percentage (0 to 100%).
5	Percentage Used: Contains a vendor specific estimate of the percentage of NVM subsystem life used based on the actual usage and the manufacturer’s prediction of NVM life. A value of 100 indicates that the estimated endurance of the NVM in the NVM subsystem has been consumed, but may not indicate an NVM subsystem failure. The value allowed to exceed 100. Percentages greater than 254 shall be represented as 255. This value shall be updated once

Byte	Description
47:32	Sectors Read: Contains the number of 512-byte user data units read from the controller; This value is reported in thousands (i.e., a value of 1 corresponds to 1000 units of 512 bytes read) and is rounded up. When the LBA size is a value other than 512 bytes, the controller shall convert the amount of data read to 512-byte units.
63:48	Sectors Written: Contains the number of 512-byte user data units written to the controller; This value is reported in thousands (i.e., a value of 1 corresponds to 1000 units of 512 bytes written) and is rounded up. When the LBA size is a value other than 512 bytes, the controller shall convert the amount of data written to 512-byte units. For the NVM* command set, logical blocks written as part of Write operations shall be included in this value.
79:64	Host Read Command: Indicates the number of read commands completed by the controller. For the NVM command set, this is the number of Compare and Read commands
95:80	Host Write Commands: Indicates the number of write commands completed by the controller. For the NVM command set, this is the number of Write commands.
111:96	Controller Busy Time: Contains the amount of time the controller is busy with I/O commands. The controller is busy when there is a command outstanding to an I/O Queue (specifically, a command was issued via an I/O Submission Queue Tail doorbell write and the corresponding completion queue entry has not been posted yet to the associated I/O Completion Queue). This value is reported in minutes.
127:112	Power Cycles: Contains the number of power cycles.
143:128	Power on Hours: Indicates the number of actively power on hours. This does not include time the controller was powered and in a lower state condition.
159:144	Number of Unsafe Shutdown: Indicates the number of unsafe shutdowns. This count is incremented when a shutdown notification (CC.SHN) is not received prior to loss of power
175:160	Number of Media Errors: Indicates number of occurrences where the controller detected an unrecovered data integrity error. Errors such as uncorrectable ECC, CRC checksum failure, or LBA tag mismatch are included in this field.
195:192	Warning Composite Temperature Time: Indicates the amount of time in minutes that the controller is operational and the Composite Temperature is greater than or equal to the Warning Composite Temperature Threshold (WCTEMP) field and less than the Critical Composite Temperature Threshold (CCTEMP) field in the Identify Controller data structure. If the value of the WCTEMP or CCTEMP field is 0h, then this field is always cleared to 0h regardless of the Composite Temperature value.
199:196	Critical Composite Temperature Time: Contains the amount of time in minutes that the controller is operational and the Composite Temperature is greater the Critical Composite Temperature Threshold (CCTEMP) field in the Identify Controller data structure. If the value of the CCTEMP field is 0h, then this field is always cleared to 0h regardless of the Composite Temperature value.

Byte	Description
201:200	Temperature Sensor 1: Contains the current temperature reported by temperature sensor 1 in degrees Kelvin.

## Limited Warranty Policy

Exascend Corporation ("Exascend") warrants that Exascend's product, in its original sealed packaging, will be free from defects in materials and workmanship. Subject to the conditions and limitations set forth below, Exascend will either repair or replace any part of its products that prove defective by reason of improper workmanship or materials. This warranty is non-transferable and valid only for the original purchaser of the Exascend products, except where prohibited by law. An original or copy sales receipt or invoice is required to establish purchase date and original purchaser.

1. This warranty supersedes all other warranties and representations, whether oral or written, between you and Exascend. Exascend makes no other warranties, including any warranty of merchantability or fitness for a particular purpose, whether expressly or implied.
2. All warranties, whether express or implied, are limited to the periods of time set forth below. Some states and jurisdictions do not allow such exclusion of implied warranties, limitations or warranty period, so above restrictions may not apply to you.
3. Exascend may acknowledge or read and save the data and information (collectively, "Information") stored in the product during after services. Exascend hereby agrees that Exascend will not disclose any Information to any third parties, except Exascend's employees, who may need to access the Information, with or without your prior written consent.



## Warranty Terms

We offer a three (3) years limited warranty for our I-temp CFexpress products.

The warranty period is the SHORTER OF:

- a period of three (3) years beginning from the date of purchase; or
- the period ending when the drive reached advertised DWPD or TBW rating; or
- The period ending when device's Lifespan indicator reaches an abnormal value.

This Limited Warranty will not apply to, and Exascend will have no liability or obligation with respect to, problems or damage resulting from any of the following: (i) accident, modification, neglect, abuse, careless or incorrect handling, misuse or improper operation, disassembly, misapplication or use in unusual physical environments or under operating conditions not approved by Exascend (including, but not limited to, use of the Product with an improper voltage supply); (ii) normal wear and tear; (iii) removal of label(s) or sticker(s) provided on or with the Product (including all warranty or quality-control stickers, product serial or electronic numbers); (iv) problems relating to or residing in non-Exascend hardware, software or other items with which the Product is used; (v) use in an environment, in a manner or for a purpose for which the Product was not designed or not in accordance with Exascend's published documentation; (vi) installation, modification, alteration or repair by anyone other than Exascend or its authorized representatives; (vii) problems that do not relate to materials or workmanship or that have an insignificant impairment on the use or operation of the Product; or (viii) problems related to consumables; (ix) Product purchased "AS-IS" or "with known faults, defects or problems." Additionally, Exascend will have no liability or obligation to recover any data in the Product.