



# I-temp CFast

(SATA, CFast, TLC, Industrial)

**Product Datasheet**

Commercial Series

SATA3 – 6Gb/s

Industrial Temperature Grade -40°C - 85°C

## Revision History

Revision	Description	Date
001	First released	March 20 <sup>th</sup> , 2022

# SI3 Series – Industrial CFast Card

## Product Specification

- **Capacity**
  - Industrial CFast: 128GB~1TB
- **Components**
  - Controller: Marvell 88SS1079
  - Flash: 3D TLC
  - DRAM: DDR3
- **Compliance**
  - SATA 3.2 compatible with 6/3/1.5 Gb/s rates
  - ATA/ATAPI ACS3 command set compliant
  - Enhance SMART ATA feature set
  - Data set management TRIM command
- **Performance (up to) \***
  - Sequential Read (Sustained) :520 MB/s
  - Sequential Write (Sustained):520 MB/s
  - Random 4K Read: 85,000 IOPS
  - Random 4K Write: 70,000 IOPS
- **Reliability**
  - Advanced LDPC error correction
  - Global static and dynamic wear leveling
  - Enhanced power loss protection
  - UBER: 1 sector per  $10^{17}$  bits read
  - MTBF: 2.0 Million Hours
- **Endurance**
  - TBW : up to 600TB (with 1TB)
- **Data Retention**
  - JESD47 Compliant
- **Compatibility**
  - Windows 10/8.1/7
  - Windows Server 2016/2012 R2/2012
  - CentOS, Fedora, FreeBSD, openSUSE, Red Hat, Ubuntu
  - VMware ESXi, Citrix, KVM
- **Mechanical Form Factor**
  - CFast: 42.8 mm x 36.4 mm x 3.6 mm
- **Power Consumption (TYP)**
  - Active: < 5.0W
  - Idle: < 0.9W
- **Environment**
  - Operating temperature: -40°C ~ 85°C
  - Storage temperature: -45°C ~ 90°C
- **Shock & Vibration**
  - Operating:
    - 50G (11ms duration, half sine wave)
  - Non-Operating:
    - 1500G (0.5ms duration, half sine wave)
  - Vibration: 10G (Peak,10~2000Hz)
- **Warranty**
  - 3 year

Specifications subject to change without notice.

\*(1)Actual performance may vary based on hardware, software, and overall system configuration.

(2)Sequential performance is measured with 128KB transfer size, QD 32 and 4KB align with IO Meter.

(3)Random performance is sustained performance measured with 4K/8K transfer size, QD 32 and 4KB align with IO Meter.

(4) Performance Test Platform: CPU - Intel Core i7 4770K, Mother Board - ASUS Z87-DELUXE, Chipset - Intel Z87 Express, OS - Windows 8.1 Pro x64

\*\* DWPD stands for Drive Writes Per Day. TBW = DWPD \* capacity \* warranty \* 365 / 1000

Access patterns used for random workload during endurance testing is compliant with JESD218 standard.

# Contents

Revision History.....	2
Contents.....	4
1. Ordering Information.....	5
2. Product Overview.....	6
3. Product Specifications.....	7
3.1 Capacity.....	7
3.2 Performance.....	8
3.3 Environmental Specifications.....	11
3.4 Power Consumption.....	12
3.5 Reliability.....	13
4. Physical Dimension Diagram.....	12
4.1 CFast Card.....	12
5. Standards Compliance.....	13
6. Supported ATA Commands.....	14
7. S.M.A.R.T Support.....	16
7.1 Overview of S.M.A.R.T Support.....	16
7.2 S.M.A.R.T Command Sets.....	16
7.3 S.M.A.R.T Sub command.....	18
Limited Warranty Policy.....	19
Warranty Terms.....	20
Contact Information.....	21

## 1. Ordering Information

The following Tables list the part No. for Exascend I-temp CFast

Table 1 CFast product list

Part Number	Capacity	Flash Type	Form Factor
EXSD3X128GB-I	128GB *	3D TLC	CFast
EXSD3X256GB-I	256GB *	3D TLC	CFast
EXSD3X512GB-I	512GB *	3D TLC	CFast
EXSD3X001TB-I	1TB **	3D TLC	CFast

\*1GB=1,000,000,000 Bytes

\*\*1TB=1,024GB

## 2. Product Overview

Exascend provides customizable hardware and firmware design, manufacturing, and service of cutting-edge SSD products and advanced storage systems. Our products are designed specifically for high reliability commercial, enterprise data center, and cloud computing applications. By combining world class design R&D, and superior execution in delivery and support capabilities, Exascend strives to provide customers with the best in class product and service, enabling enhanced boot times, faster application load times, reduced power consumption and extended reliability.

Exascend SI3 series product support CFast form factors, integrating high speed SATA 3 interface with advanced NAND flash memory management technology, delivering capacities up to 1TB.

Exascend SI3 series products are offered in two product categories with different over-provisioning. Key product highlights include:

- High I/O and throughput performance
- Next generation LDPC technology secures NAND endurance
- Advanced Flash management and global wear leveling algorithm extending drive life
- Exceptional reliability and stability
- Temperature monitoring and throttling

### 3. Product Specifications

Exascend SI3 series CFast provides you the ultimate performance and ultra-high reliability over traditional hard disk drive by achieving up to 520MB/s for sequential read, 520MB/s for sequential write, 85,000IOPS for 4K random read, 70,000IOPS for full drive 4K random write.

Exascend SI3 series CFast consists solely of semiconductor devices, it does not contain any mechanical part such as platter (disk), motor and suspension as traditional hard disk drive. Thus, it exhibits superior performance, capacity, reliability, ruggedness, low power, and small form factor profiles that qualified to be the best storage solution for enterprise application with extreme workloads and increased MTBF requirements.

Exascend SI3 CFast uses a single-chip Flash controller to manage multiple NAND Flash memory modules. The controller works with a host system to allow data to be written to and read from the Flash memory modules through a SATA interface.

#### 3.1 Capacity

Table 2 User Addressable Sectors

<b>SI3 CFast Series</b>	<b>Unformatted Capacity (Total User Addressable Sectors in LBA mode)</b>
128GB *	250,069,680
256GB *	500,118,192
512GB *	1,000,215,216
1TB **	2,000,409,264

\*1GB=1,000,000,000 Bytes

\*\*1TB=1,024GB

Notes:

- (1) LBA count shown represents total user storage capacity and will remain the same throughout the life of the drive.
- (2) The total usable capacity of the SSD may be less than the total physical capacity because a small portion of the capacity is used for NAND flash management and maintenance purposes.

## 3.2 Performance

Table 3 Drive Performance – S13 CFast

Parameter	Capacity				Unit
	128GB	256GB	512GB	1TB	
Sequential Read (Sustained)	520	520	520	520	MB/s
Sequential Write (Sustained)	180	300	400	520	MB/s
Random Read	30,000	35,000	65,000	85,000	IOPS
Random Write	15,000	30,000	65,000	70,000	IOPS

Specifications subject to change without notice.

Notes:

- (1) Drive is connected as secondary
- (2) Actual performance may vary based on hardware, software, and overall system configuration.
- (3) Sequential performance is measured with 128KB transfer size, QD 32 and 4KB align with IO Meter.
- (4) Random performance is sustained performance measured with 4K/8K transfer size, QD 32 and 4KB align with IO Meter.
- (5) Test Platform: CPU - Intel Core i7 4770K, Mother Board - ASUS Z87-DELUXE, Chipset - Intel Z87 Express, OS - Windows 8.1 Pro x64



### 4.3 Environment Specification

Table 4 Environmental Specification Table

Parameter	Value
Operating Temperature	-40°C ~ 85°C
Storage Temperature	-45°C ~ 90°C
Power Supply Voltage Range	CFast : 3.3V ± 5%
Humidity (non-condensing)	5%~95% (Operating)
Vibration	10G(Peak,10~2000Hz)
Shock (Operating)	50G, (11ms duration, half sine wave)
Shock (Non-Operating)	1500G, (0.5ms duration, half sine wave)

## 4.4 Power Consumption

Table 5 Power Consumption Table

Parameter	Unit	S13 series			
		128GB	256GB	512GB	1TB
Active Write-Average	W	<3.75	<3.75	<3.8	<3.875
Active Write-Burst	W	<5.1	<5.1	<5.1	<5.725
Active Read-Average	W	<1.55	<1.55	<1.6	<1.475
Active Read-Burst	W	<2.2	<2.2	<2.25	<2.3
Idle	W	<0.5	<0.5	<0.5	<0.5

## 4.5 Reliability

S13 series products meet or exceed SSD endurance and data retention requirements as specified in the JESD218 standard. Reliability specifications are listed in the following table.

Table 6 Reliability table

Parameter	Value
<p><b>Mean Time Between Failures (MTBF)</b></p> <p>Mean Time Between Failures is a measure of how reliable a hardware product of component is. It's the mean time between failures which describe the expected time between two failures. It is tested through reliability demonstration test (RDT).</p>	<p>2,000,000 hours</p>
<p><b>Uncorrectable Bit Error Rate (UBER)</b></p> <p>Uncorrectable bit error rate will not exceed one sector in the specified number of bits read. In the unlikely event of a non-recoverable read error ,the SSD will report it as a read failure to the host; the sector in error is considered corrupt and is not returned to the host</p>	<p><math>&lt;10^{-17}</math></p>
<p><b>Endurance Rating (TBW)</b></p> <p>TBW stands for total bytes written whose access pattern is compliant with JESD218 standard.</p>	<p>128GB: 75TB                      256GB: 150TB                      512GB: 300TB                      1TB: 600TB</p>

## 4. Physical Dimension Diagram

### 5.1 CFast Card

Figure 3: Physical Dimension Diagram for CFast Card

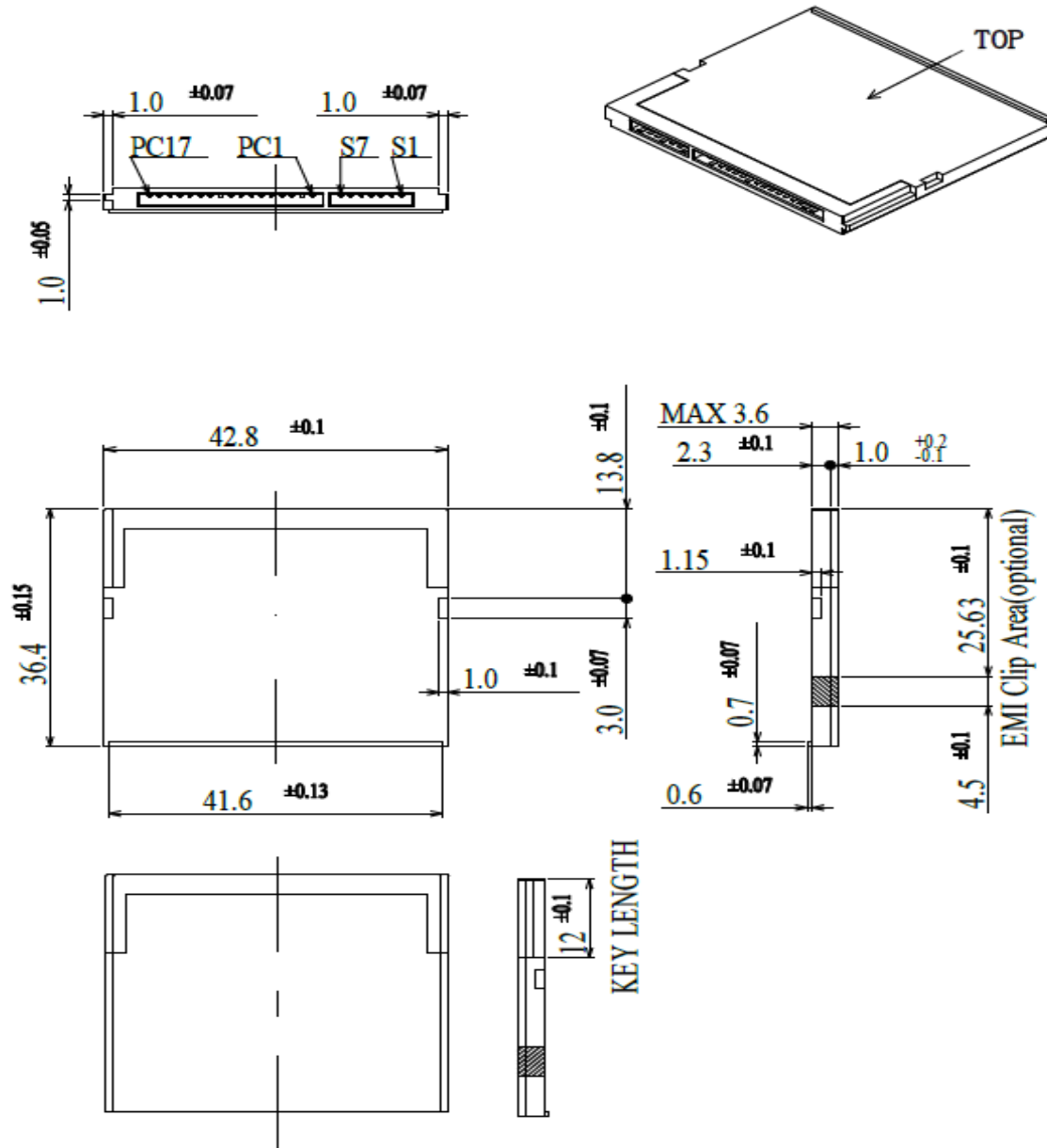

Table 7 Physical Dimension for CFast Card

Physical Dimensions	Value	Unit
Length	42.8	mm
Width	36.4	mm
Thickness	3.6	mm

## 5. Standards Compliance

Exascend SI3 series I-temp CFast Card complies with following standards:

FCC

CE

RoHS

## 6. Supported ATA Commands

Exascend SI3 series CFast Card supports ATA commands that are shown as following table. For details of the ATA command, please refer to the ATA/ATAPI ACS3 command set.

Table 15 Supported ATA Command

Command Name	Code (Hex)	Command Name	Code (Hex)
NOP	00h	Read Multiple	C4h
Data Set Management	06h	Write Multiple	C5h
Read Sectors	20h	Set Multiple Mode	C6h
Read Sectors EXT	24h	Read DMA	C8h
Read DMA EXT	25h	Write DMA	CAh
Read Native Max Address EXT	27h	Write Multiple FUA EXT	CEh
Read Multiple EXT	29h	Standby Immediate	E0h
Read Log EXT	2Fh	IDLE Immediate	E1h
Write Sectors	30h	Standby	E2h
Write Sectors EXT	34h	IDLE	E3h
Write DMA EXT	35h	Read Buffer	E4h
Set Max Address EXT	37h	Check Power Mode	E5h
Write Multiple EXT	39h	Sleep	E6h
Write DMA FUA EXT	3Dh	Flush Cache	E7h
Write Log EXT	3Fh	Write Buffer	E8h
Read Verify Sectors	40h	Read Buffer DMA	E9h
Read Verify Sectors EXT	42h	Flush Cache EXT	EAh
Write Uncorrectable EXT	45h	Write Buffer DMA	EBh
Read Log DMA EXT	47h	Identify Device	ECh
Write Log DMA EXT	57h	Set Features	EFh
Read FPDMA Queued	60h	Security Set Password	0xF1
Write FPDMA Queued	61h	Security Unlock	0xF2
Set Date & Time EXT	77h	Security Erase Prepare	0xF3
Accessible Max Address	78h	Security Erase Unit	0xF4
Execute Device Diagnostic	90h	Security Freeze Lock	0xF5
Download MicronCode	92h	Security Disable Password	0xF6
Download MicroCode DMA	93h	Read Native Max Address	0xF8

<b>Command Name</b>	<b>Code (Hex)</b>	<b>Command Name</b>	<b>Code (Hex)</b>
SMART	B0h	Set Max Address	0xF9
Sanitize Device	B4h		

## 7. S.M.A.R.T Support

### 9.1 Overview of S.M.A.R.T Support

Data storage drives capture a variety of information during operation that may be used to analyze drive “health.” Drive manufacturers have adopted S.M.A.R.T. (Self-Monitoring, Analysis, and Reporting Technology) to help warn system software, a system administrator, or a user of impending drive failure, while time remains to take preventive action. The technical documentation for S.M.A.R.T. is captured in the AT Attachment (ATA) standard. The standard defines the protocols for reporting errors and for invoking self-tests to collect and analyze data on demand. The ATA specification is flexible and provides for individual manufacturers to define their own unique vendor specific information. This section describes the baseline S.M.A.R.T. Commands and Attributes supported by the EXSAM3 series products. The information herein should be used in conjunction with the ATA standard and related documents, which may serve as references for topics and details not addressed here. Further, it is recommended to consult the list of public S.M.A.R.T. Attributes.

### 9.2 S.M.A.R.T Command Sets

SI3 CFast Card currently provides a list of S.M.A.R.T Attributes as below

Table 16 Supported S.M.A.R.T Attributes

ID (Dec)	ID(Hex)	Attribute Name	Description
1	01h	Raw Read Error Rate	Total event count for all correctable and un-correctable ecc, it would be cleared to 0 when exceeding FFFFFFFFh
5	05h	Retired Block Count	Retired block count after leaving factory
9	09h	Power-On Hours	Power on time, culmulative over the life of the device, integer number in hour time units
12	0Ch	Device Power Cycle Count	Culmulative number of power cycle events over the life of the device
165	A5h	Maximum Erase Count	Maximum erase count of all the blocks in the device
166	A6h	Minimum Erase Count	Minimum erase count of all the blocks in the device
167	A7h	Average Erase Count	Average erase count of all the blocks in the device
169	A9h	Remain life/Media Wearout Indicator	Indicate the worn-out status of the device
170	AAh	Available Reserved Space	Percentage of reserved blocks remaining in op
ID (Dec)	ID(Hex)	Attribute Name	Description
171	ABh	Program Fail Count	Total count of program fails



172	ACh	Erase Fail Count	Total count of erase fails
174	AEh	Unexpected Power Loss	Total count of unexpected power loss events
183	B7h	Total Sata Link Down Grade Link Count	Total count of the number of times SATA interface selected lower signaling rate due to error Byte0~1: count of failing SATA connection Byte2~3: count of SATA1 Byte4~5: count of SATA2
194	C2h	Temperature	Byte0~1: current temperature Byte2~3: minimum temperature Byte4~5: maximum temperature
198	C6h	ECC On-the-Fly Error Count	Count of un-correctable ecc (UECCC). It is cleared at power-on reset.
199	C7h	Current Sata Interface Crc Count	Count of SATA interface CRC during this power on, it would be cleared to zero during power off
241	F1h	Lifetime Writes from Host System	Data written by host (GB=1024*1024*1024 Byte)
242	F2h	Lifetime Reads to Host System	Data read to host (GB=1024*1024*1024 Byte)
249	F9h	Total Nand Writes	Total data written to NAND (GB=1024*1024*1024 Byte)
250	FAh	Current Sata Link Down Grade Link Count	Count of the number of times SATA interface selected lower signaling rate due to error during this power on, it would be cleared to 0 during power off Byte0~1: count of failing SATA connection Byte2~3: count of SATA1 Byte4~5: count of SATA2
251	FBh	Total Sata Interface Crc Count	Life-time SATA interface CRC count

More attributes could be supported which depends on customers' detailed requirements.

### 9.3 S.M.A.R.T Sub command

The SMART feature set command has several separate sub-commands which are selective by host to write it to the devices' features registers before issuing the S.M.A.R.T. The sub-commands are listed below.

Table 5 S.M.A.R.T sub command

Command	Sub-Code
Smart Read Data	D0
Smart Read Attribute Thresholds	D1
Smart Enable/Disable Attribute AutoSave	D2
Smart Execute Off-Line Immediate	D4
Smart Read Log	D5
Smart Write Log	D6
Smart Enable Operations	D8
Smart Disable Operations	D9
Smart Return Status	DA

## Limited Warranty Policy

Exascend Corporation ("Exascend") warrants that Exascend's product, in its original sealed packaging, will be free from defects in materials and workmanship. Subject to the conditions and limitations set forth below, Exascend will either repair or replace any part of its products that prove defective by reason of improper workmanship or materials. This warranty is non-transferable and valid only for the original purchaser of the Exascend products, except where prohibited by law. An original or copy sales receipt or invoice is required to establish purchase date and original purchaser.

1. This warranty supersedes all other warranties and representations, whether oral or written, between you and Exascend. Exascend makes no other warranties, including any warranty of merchantability or fitness for a particular purpose, whether expressly or implied.
2. All warranties, whether express or implied, are limited to the periods of time set forth below. Some states and jurisdictions do not allow such exclusion of implied warranties, limitations or warranty period, so above restrictions may not apply to you.
3. Exascend may acknowledge or read and save the data and information (collectively, "Information") stored in the product during after services. Exascend hereby agrees that Exascend will not disclose any Information to any third parties, except Exascend's employees, who may need to access the Information, with or without your prior written consent.

## Warranty Terms

We offer a three (3) years limited warranty for our I-temp CFast card products.

The warranty period is the SHORTER OF:

- a period of three (3) years beginning from the date of purchase; or
- the period ending when the drive reached advertised DWPD or TBW rating; or
- the period ending when device's Lifespan indicator reaches an abnormal value.

This Limited Warranty will not apply to, and Exascend will have no liability or obligation with respect to, problems or damage resulting from any of the following: (i) accident, modification, neglect, abuse, careless or incorrect handling, misuse or improper operation, disassembly, misapplication or use in unusual physical environments or under operating conditions not approved by Exascend (including, but not limited to, use of the Product with an improper voltage supply); (ii) normal wear and tear; (iii) removal of label(s) or sticker(s) provided on or with the Product (including all warranty or quality-control stickers, product serial or electronic numbers); (iv) problems relating to or residing in non-Exascend hardware, software or other items with which the Product is used; (v) use in an environment, in a manner or for a purpose for which the Product was not designed or not in accordance with Exascend's published documentation; (vi) installation, modification, alteration or repair by anyone other than Exascend or its authorized representatives; (vii) problems that do not relate to materials or workmanship or that have an insignificant impairment on the use or operation of the Product; or (viii) problems related to consumables; (ix) Product purchased "AS-IS" or "with known faults, defects or problems." Additionally, Exascend will have no liability or obligation to recover any data in the Product.