

NOTICE OF PROPRIETARY RIGHTS THIS DOCUMENT CONTAINS CONFIDENTIAL DATA, INCLUDING TRADE SECRETS, PROPRIETARY TO TIMES MICROWAVE SYSTEMS. DISCLOSURE OF THIS DATA IS EXPRESSLY CONDITIONED UPON YOUR ASSENT THAT ITS USE IS LIMITED TO USE WITHIN YOUR COMPANY ONLY. ANY OTHER USE IS STRICTLY PROHIBITED WITHOUT THE PRIOR WRITTEN CONSENT OF TIMES MICROWAVE SYSTEMS.

SYM	REVISION DESCRIPTION	DFTM	DATE	APPD	DATE
A	RELEASED FOR PRODUCTION	JW	08/08/2014	TZ	08/08/2014

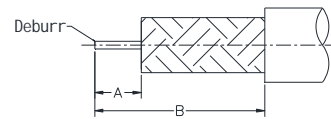
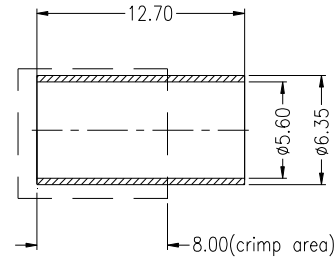
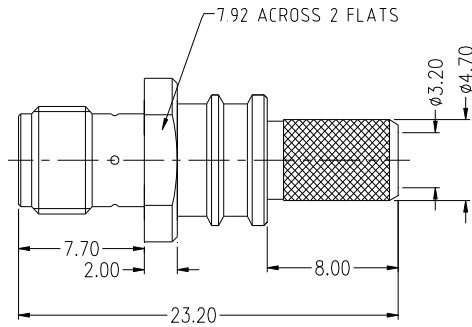

Strip Length	A	B
mm	3.81	20.32

Recommended cable stripping dim's
Connector adds: 9.02mm

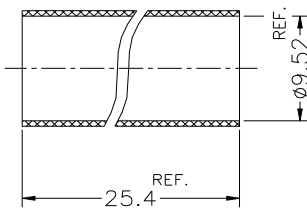

Heat Shrink Tube

I. MATERIALS & FINISHES

Components	Materials	Finishes	Thk. (μ'')
Body	STAINLESS STEEL	PASSIVATION	--
Center Cont.	BeCu	Gold	50
Insulator	TEFLON	--	--
Gasket	--	--	--
Ferrule	Brass	Albaloy	80
Coupling nut	--	--	--

II. ELECTRICAL PROPERTIES

Impedance (Ω):	50
Frequency Range (GHz):	DC to 6.0
Working Voltage (V):	500
Insulation Resistance (MΩ):	≥5000
VSWR:	1.30:1
Insertion Loss:	0.05 x sqrt(f)

III. ENVIRONMENT PROPERTIES

Temperature Range:	-55°C~+125°C
Thermal Shock:	MIL-STD 202G, Meth.107, Cond.B
Vibration:	MIL-STD 202G, Meth.204, Cond.B
Shock:	MIL-STD 202G, Meth.213, Cond I
Climatic Class:	IEC 60068 55/155/56
(2002/95/EC)RoHS:	Compliant

IV. MECHANICAL PROPERTIES

Center Cont.:	Captive
Outer Cont.:	Crimp
Coupling Nut Torque (N.m):	N/A
Cbl-Connector Retention Force (N):	230
Durability (cycles):	≥500

V. TOOLING

Stripping Tool:	3192-102/CST-195/200
Crimping Tool:	3190-667

MATL:		UNLESS OTHERWISE SPECIFIED			DFTM. JW		TIMES MICROWAVE SYSTEMS						
USED ON: O		ALL DIMENSIONS ARE IN mm MACHINED SURFACES FINISH 1.6 RMS MAX. REMOVE ALL BURRS 0.15X45° MAX. BREAK MACHINE CORNERS 0.15X45° D MAX. FILLET R. TOLERANCES ON DECIMALS .X ±0.3 .XX ±0.15 ANGLES ±2° FRACTIONS ±N/A			DATE 14/08/08						EZ-200-SF-SS-X SMA Female (Jack) Straight No Braid Trim Connector for LMR-200 Cable Type(s)		
SCALE: N/A		DO NOT SCALE DRAWING		DATE 14/08/08		CHKD. KG		DATE 14/08/08					
DWG SIZE A		CODE IDENT 68999		DATE 14/08/08		APPD. TZ		SHT 1 of 1					
								3190-6007		REV A			