

NOTICE OF PROPRIETARY RIGHTS THIS DOCUMENT CONTAINS CONFIDENTIAL DATA, INCLUDING TRADE SECRETS, PROPRIETARY TO TIMES MICROWAVE SYSTEMS. DISCLOSURE OF THIS DATA IS EXPRESSLY CONDITIONED UPON YOUR ASSENT THAT ITS USE IS LIMITED TO USE WITHIN YOUR COMPANY ONLY. ANY OTHER USE IS STRICTLY PROHIBITED WITHOUT THE PRIOR WRITTEN CONSENT OF TIMES MICROWAVE SYSTEMS.

SYM	REVISION DESCRIPTION	DFTM	DATE	APPD	APPD
A	RELEASED FOR PRODUCTION	Joslen	2016.06.14	TZ	2016.06.14

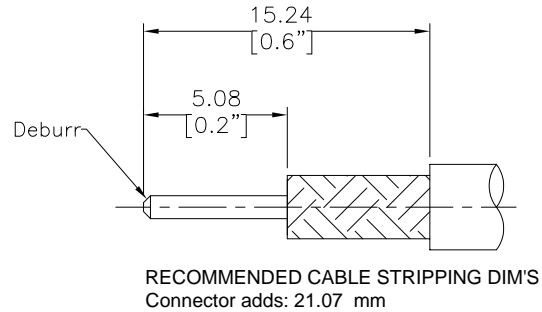
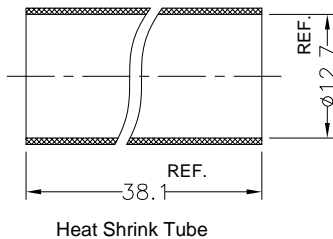
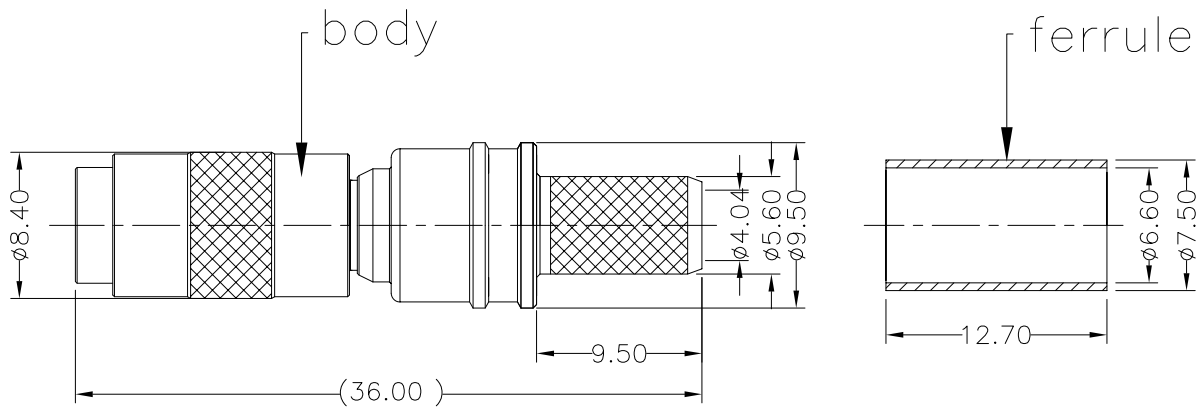

I. MATERIALS & FINISHES

Components	Materials	Finishes	Thk. (μ")
Body	Brass	Albaloy	80
Center Cont.	QBe2	Gold	50
Ferrule	Brass	Albaloy	80
Insulator	PTFE	--	--

II. ELECTRICAL PROPERTIES

Impedance (Ω):	50
Frequency Range (GHz):	DC to 6 GHz
Working Voltage (V):	500
Insulation Resistance (MΩ):	≥5000
VSWR:	≤1.30
Insertion Loss(dB, f/GHz):	-0.1x √f

III. ENVIRONMENT PROPERTIES

Temperature Range:	-55°C~+125°C
Thermal Shock:	MIL-STD 202G, Meth.107, Cond.B
Vibration:	MIL-STD 202G, Meth.204, Cond.B
Shock:	MIL-STD 202G, Meth.213, Cond I
Climatic Class:	IEC 60068 55/155/56
(2002/95/EC)RoHS:	Compliant



IV. MECHANICAL PROPERTIES

Center Cont.:	Captive
Outer Cont.:	Crimp
Coupling Nut Torque (N.m):	N/A
Cbl-Connector Retention Force (N):	200
Durability (cycles):	500

V. TOOLING

Stripping Tool: 3192-152/CST-240A
Crimping Tool: 3190-667/CT-240/200/100

According to Standard: DIN 41626

MATL:	UNLESS OTHERWISE SPECIFIED		DFTM.	Joslen	
	ALL DIMENSIONS ARE IN mm MACHINED SURFACES FINISH 1.6 RMS MAX. REMOVE ALL BURRS 0.15X45° MAX. BREAK MACHINE CORNERS 0.15X45° D MAX. FILLET R. TOLERANCES ON DECIMALS .X ±0.3 .XX ±0.15 ANGLES ±2° FRACTIONS ± N/A		DATE	2016.06.14	
USED ON: O			CHKD	KG	EZ-240-1023M-X 1.0-2.3 Male (Plug) Straight Non-Solder Pin No Braid Trim Connector for LMR-240 Cable
			DATE	2016.06.14	
SCALE: N/A	DWG SIZE: A4	DO NOT SCALE DRAWING	APPD	TZ	 1 OF 1
		CODE IDENT: 68999	DATE	2016.06.14	
					REV: A