



**Ag102 Evaluation Board
User Manual**

Rev 1.0 – June 2010

1 Table of Contents

1	Table of Contents	1
2	Table of Figures	1
3	Introduction	2
4	Board Description	2
4.1	<i>Input</i>	<i>2</i>
4.2	<i>Output</i>	<i>3</i>
4.3	<i>Capacity Selection.....</i>	<i>3</i>
4.4	<i>Simulated Thermal Offset.....</i>	<i>4</i>
4.5	<i>Status Output</i>	<i>4</i>
5	Using the Board	6
6	EVALAg1x2 Evaluation Board Schematic	7

2 Table of Figures

Figure 1:	Board Layout.....	2
Figure 2:	Capacity selection link.....	3
Figure 3:	Ag102 Status Output.....	5
Figure 4:	Example set-up	6
Figure 5:	EVALAg1x2 1R Schematic.....	7

3 Introduction

This manual is a guide to using the “EVALAg1x2” (Rev 1R or higher) evaluation board with our Ag102 Sealed Lead Acid (SLA) battery charger module. The EVALAg1x2 evaluation board can be powered by a bench power supply with a range of 9V to 36V and will charge SLA batteries with a capacity between 1.2Ah and 7Ah.

4 Board Description

4.1 Input

The input power is supplied to the board through connector J12 (see Figure 1), this is a standard 2.5mm DC10 connector. The centre pin of the connector is positive and the outer is negative. The input current can be measure by removing LK1 and connecting an ammeter across these pin.

LED1 will be illuminated when the input supply is ON.

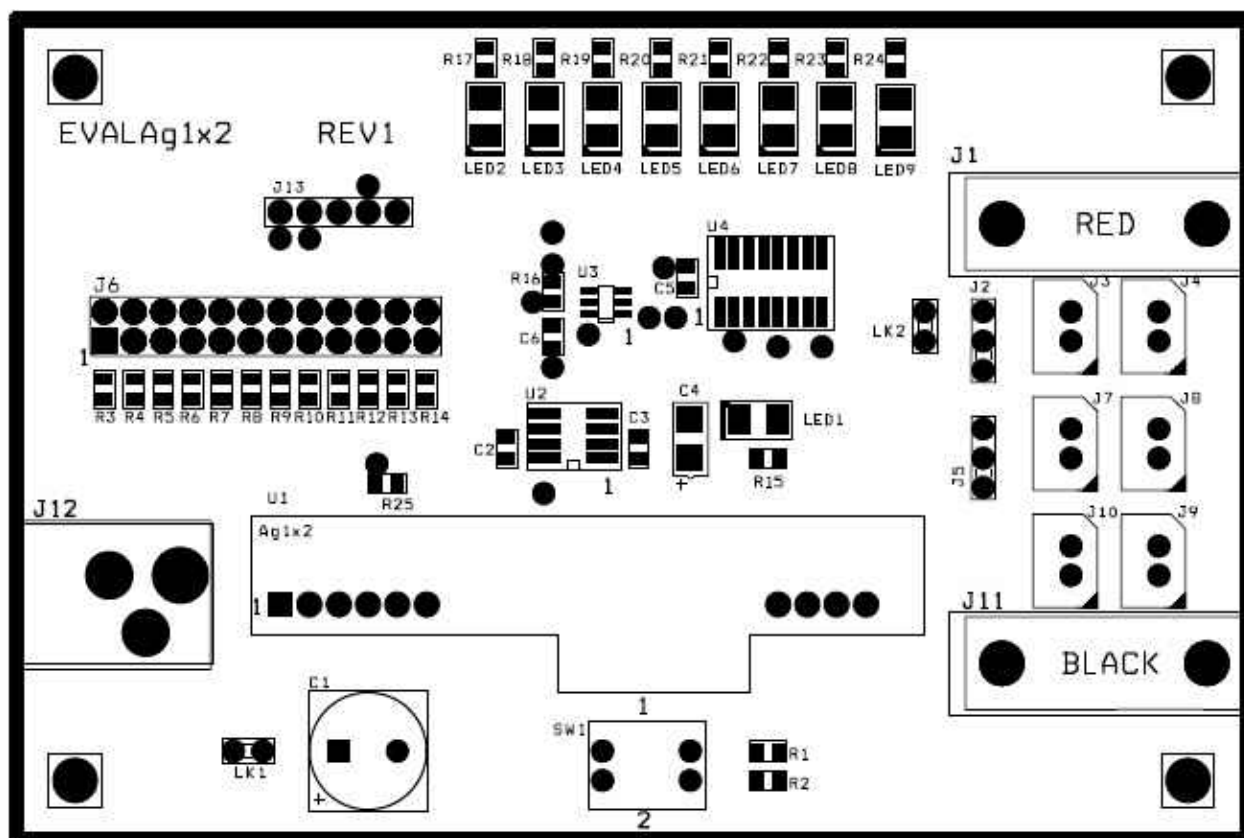

Figure 1: Board Layout

4.2 Output

The output connections to the SLA battery are made through J1 (positive) and J11 (negative). The output current can be measured by removing LK2 and connecting an ammeter across these pins.

4.3 Capacity Selection

The EVALAg1x2 evaluation board can set the Ag102 capacity from 1.2Ah to 7Ah by setting the corresponding jumper link on J6 (see Figure 2 and Table 1).

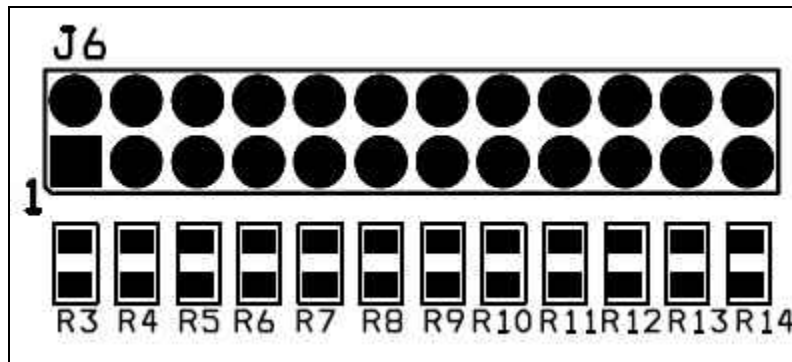

Figure 2: Capacity selection link

J6 Resistor Selection	R _{CS} Resistance (Ohms ±1%)	Battery Capacity (Ah)	Min Input Voltage (V)	Bulk Charge Current Limit (A) ±10%
R3	1K	1.2	9	0.3
R4	2K7	2	9	0.5
R5	4K3	2.1	9	0.525
R6	6K8	2.3	9	0.575
R7	10K	2.8	9	0.7
R8	15K	3.2	12	0.8
R9	24K	4	12	1
R10	43K	7	12	1

Table 1: Output Connections

Note: to prevent damaging the battery it is important that the correct value of RCS is set. If the selector link is not fitted, then the Ag102 will default to 1.2Ah capacity.

4.4 Simulated Thermal Offset

During Float charge SW1 can be used to demonstrate how the voltage changes to compensate for the change in battery temperature if an appropriate thermistor is fitted. With both switch positions open, the Ag102 will default to a 25°C ambient charge voltage.

When switch No. 1 is closed R1 (220K) this will simulate a battery temperature lower than 25°C and the output voltage will be increase.

When switch No. 2 is closed (18K) this will simulate a battery temperature higher than 25°C and the output voltage will decrease (this response will be slow when the Ag102 is float charging).

When both switches are closed this will simulate a battery temperature higher than 50°C, the output will switch OFF and the over temperature error LED (5) will illuminate. Opening one or both switches will return the Ag102 to its normal charge mode.

4.5 Status Output

The Ag102 status output pin is connected to a PIC10F200 μ -controller as detailed in the application note "AN102-3". The EVALAg1x2 board used a 3-8 decoder IC (74HC138) to drive LEDs (2 to 9) displaying the status of the Ag102 (see Figure 3).

1. When the battery is charging LED9 (Normal Charge) will be illuminated.
2. When the Ag102 detects a low battery capacity, it will continue to charge the battery and LED3 (Battery Capacity Warning) will be illuminated.
3. When the battery is disconnected the Ag102, LED4 will be illuminated.
4. When the Ag102 detects the (simulated) thermistor has exceeded 50°C, it will stop charging the battery and LED5 (Over Temperature) will be illuminated. When the Ag102 detects that the battery temperature has dropped back below 50°C, it will resume charging the battery (as shown in No.1 above)

- When the Ag102 detects that excessive current is being drawn from the output, it will stop charging the battery and LED6 (Over Current) will illuminate. This is considered to be a major fault condition that needs manual intervention. Therefore the power to the evaluation board has to be removed and reapplied before the Ag102 will resume charging the battery.

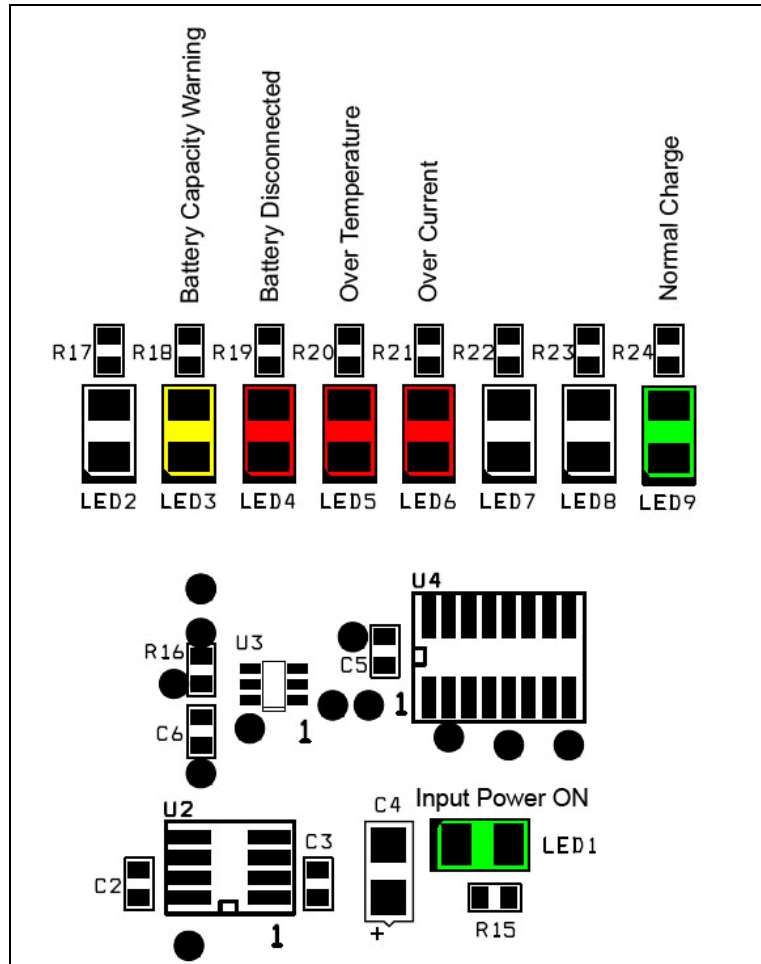

Figure 3: Ag102 Status Output

5 Using the Board

Figure 4 shows an example set-up using the Ag102 to charge a 7Ah SLA battery. For a 7Ah battery the J6 link is set to the R10 position.

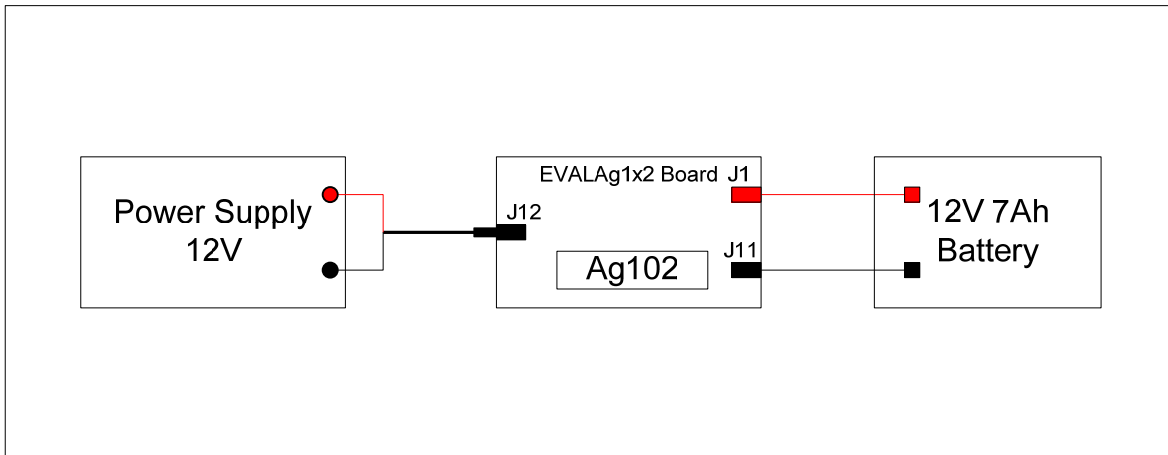

Figure 4: Example set-up