

HEKLA-G2-C

Version compatible with COBs of 13.5 x 13.5 mm packages and max 11.6 mm LES size

TECHNICAL SPECIFICATIONS:

Dimensions	Ø 44.0 mm
Height	5.5 mm
Fastening	screw
ROHS compliant	yes ⓘ

MATERIAL SPECIFICATIONS:

Component	Type	Material	Colour	Finish
HEKLA-G2-C	Base part	PBT	white	

ORDERING INFORMATION:

Component	Qty in box	MOQ	MPQ	Box weight (kg)
F17435_HEKLA-G2-C » Box size: 385 x 290 x 235 mm	1710	45	45	10.2

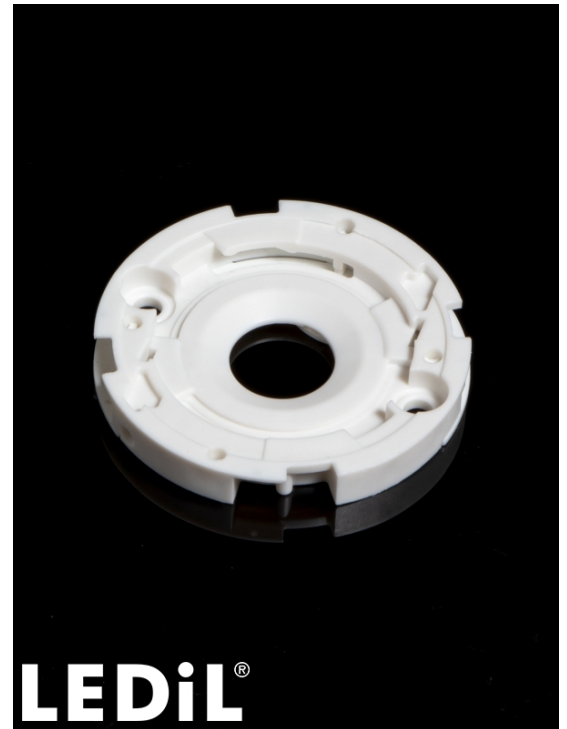

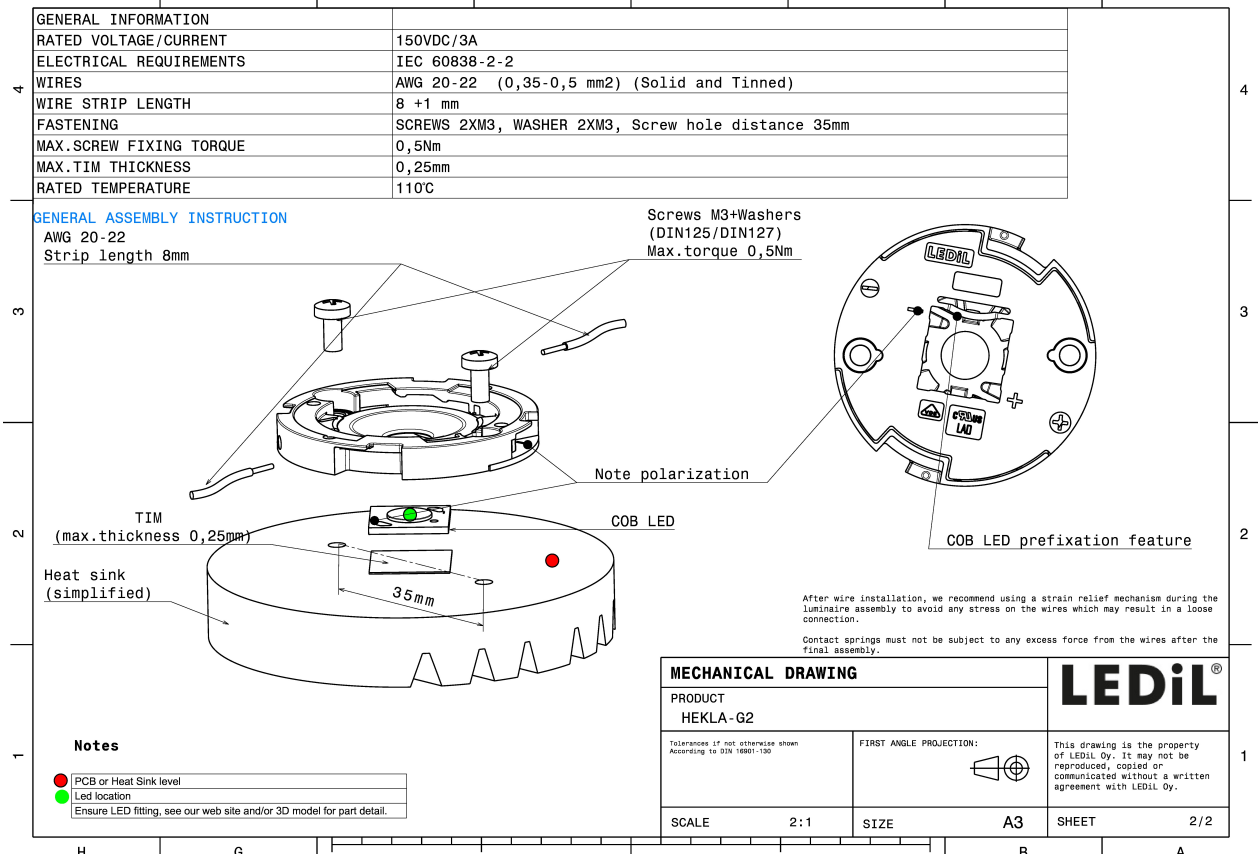
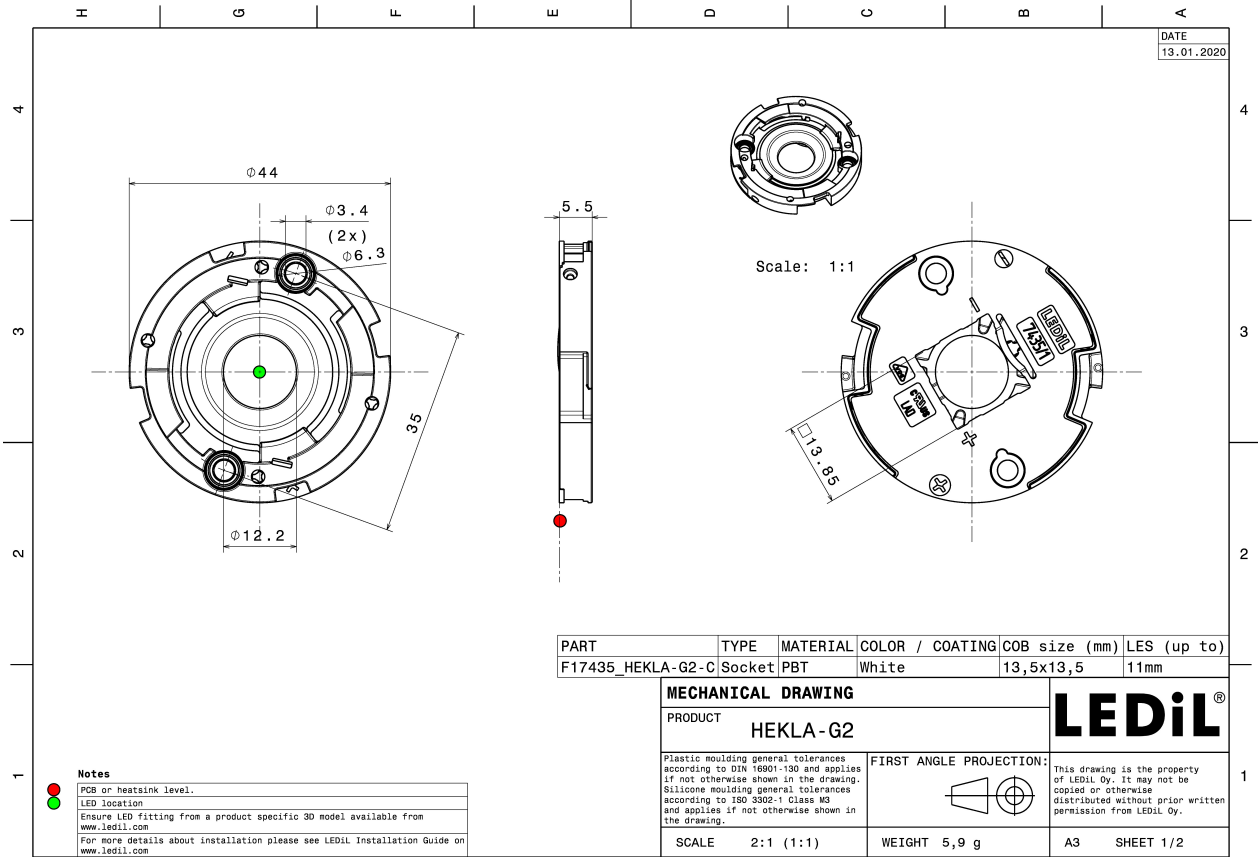

See also our general installation guide: www.ledil.com/installation_guide