

## HEKLA-G2-H

Version compatible with COBs of 16 x 19 mm packages and max 14 mm LES size

### TECHNICAL SPECIFICATIONS:

Dimensions	Ø 44.0 mm
Height	5.6 mm
Fastening	screw
ROHS compliant	yes ⓘ

### MATERIAL SPECIFICATIONS:

Component	Type	Material	Colour	Finish
HEKLA-G2-H	Base part	PBT	white	

### ORDERING INFORMATION:

Component	Qty in box	MOQ	MPQ	Box weight (kg)
F17437_HEKLA-G2-H » Box size: 385 x 290 x 235 mm	1710	45	45	10.0

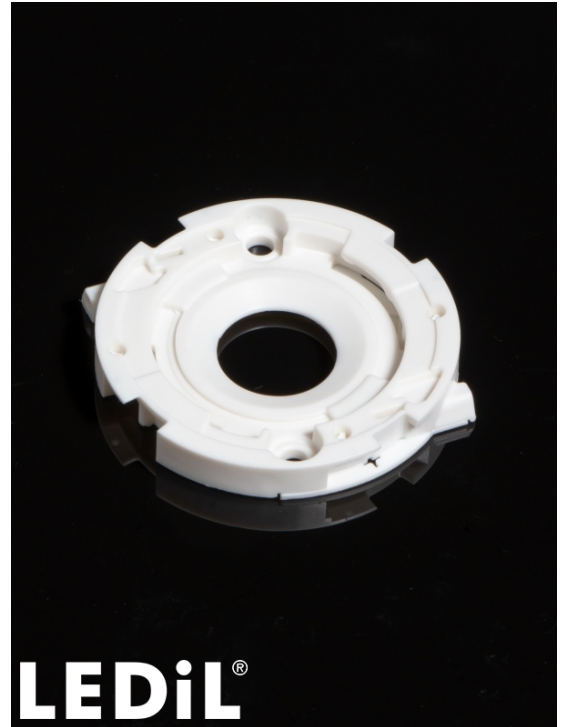

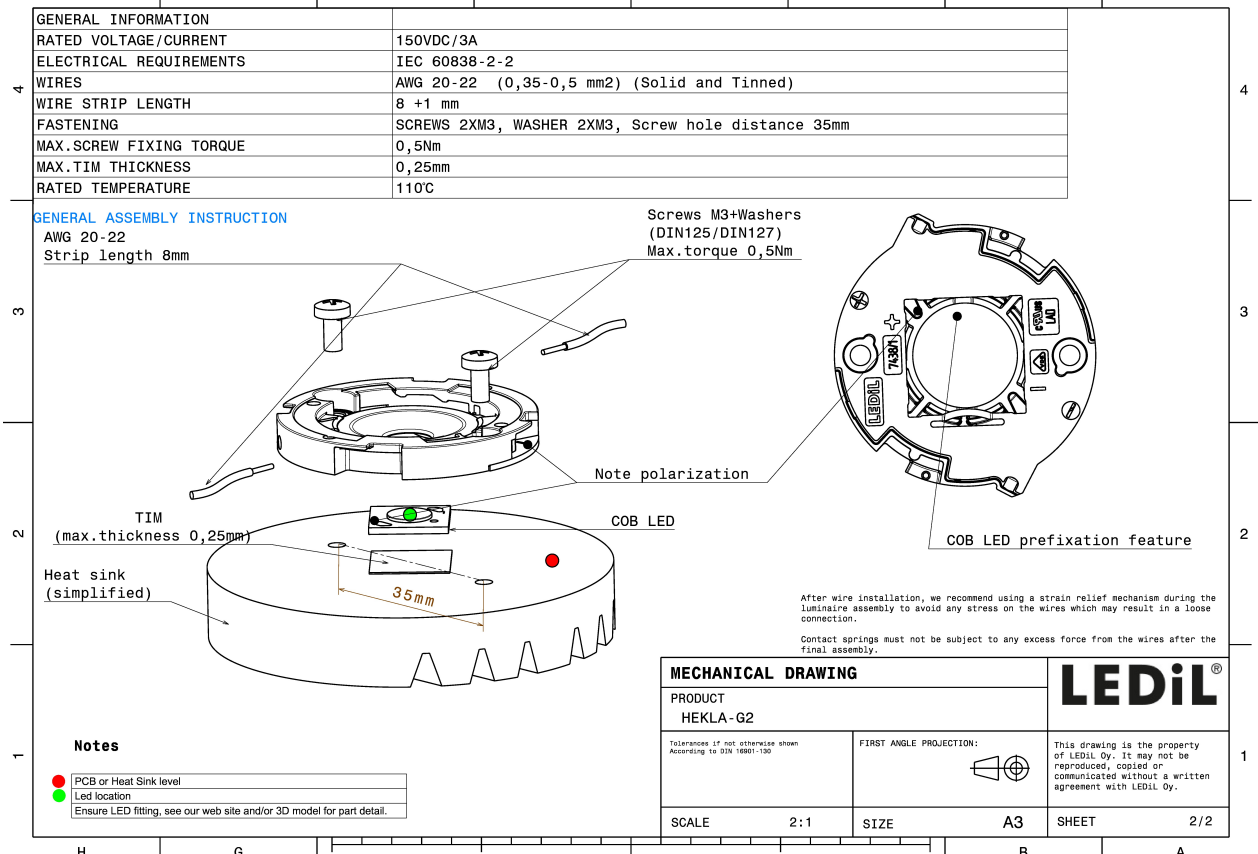
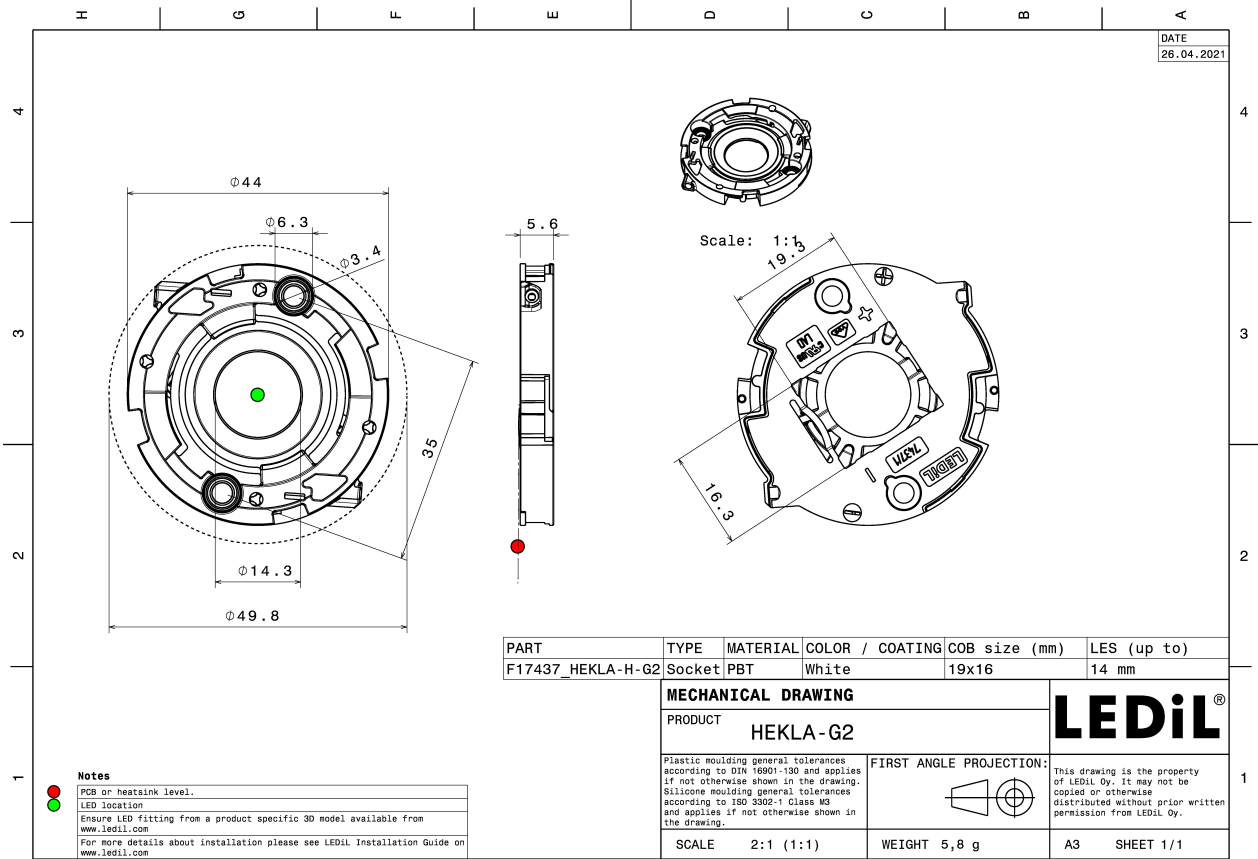

See also our general installation guide: [www.ledil.com/installation\\_guide](http://www.ledil.com/installation_guide)